

NEO-M8P

u-blox M8 high precision GNSS modules

Data Sheet

Highlights

- Centimeter-level GNSS positioning for the mass market
- Integrated Real Time Kinematics (RTK) for fast time-to-market
- Smallest, lightest, and energy-efficient RTK module
- Complete and versatile solution due to base and rover variants
- World-leading GNSS positioning technology



www.u-blox.com

UBX-15016656 - R02

Document Information

| | | | |
|--------------------------|---------------------------------------|-------------|--|
| Title | NEO-M8P | | |
| Subtitle | u-blox M8 high precision GNSS modules | | |
| Document type | Data Sheet | | |
| Document number | UBX-15016656 | | |
| Revision and date | R02 | 15-Feb-2016 | |
| Document status | Advance Information | | |

Document status explanation

| | | | |
|------------------------------|--|--|--|
| Objective Specification | Document contains target values. Revised and supplementary data will be published later. | | |
| Advance Information | Document contains data based on early testing. Revised and supplementary data will be published later. | | |
| Early Production Information | Document contains data from product verification. Revised and supplementary data may be published later. | | |
| Production Information | Document contains the final product specification. | | |

This document applies to the following products:

| Product name | Type number | ROM / FLASH version | PCN / IN reference |
|--------------|--------------|----------------------|--------------------|
| NEO-M8P | NEO-M8P-0-10 | FLASH FW3.01 HPG1.00 | N/A |
| NEO-M8P | NEO-M8P-2-10 | FLASH FW3.01 HPG1.00 | N/A |

u-blox reserves all rights to this document and the information contained herein. Products, names, logos and designs described herein may in whole or in part be subject to intellectual property rights. Reproduction, use, modification or disclosure to third parties of this document or any part thereof without the express permission of u-blox is strictly prohibited.

The information contained herein is provided "as is" and u-blox assumes no liability for the use of the information. No warranty, either express or implied, is given, including but not limited, with respect to the accuracy, correctness, reliability and fitness for a particular purpose of the information. This document may be revised by u-blox at any time. For most recent documents, visit www.u-blox.com.

Copyright © 2016, u-blox AG.

u-blox® is a registered trademark of u-blox Holding AG in the EU and other countries. ARM® is the registered trademark of ARM Limited in the EU and other countries.

Contents

| | |
|--|-----------|
| Contents..... | 3 |
| 1 Functional description..... | 5 |
| 1.1 Overview | 5 |
| 1.2 Product features | 5 |
| 1.3 Performance | 6 |
| 1.4 Block diagram..... | 7 |
| 1.5 GNSS..... | 7 |
| 1.5.1 GPS..... | 7 |
| 1.5.2 GLONASS..... | 7 |
| 1.6 Rover navigation modes | 7 |
| 1.6.1 Operation..... | 7 |
| 1.6.2 RTK Operation..... | 8 |
| 1.7 Base station modes (NEO-M8P-2) | 8 |
| 1.7.1 Fixed stationary mode | 8 |
| 1.7.2 Survey-in function for fixed stationary mode | 9 |
| 1.7.3 Communication link | 9 |
| 1.8 Raw Data..... | 9 |
| 1.9 Assisted GNSS (A-GNSS) | 9 |
| 1.9.1 AssistNow™ Online..... | 9 |
| 1.10 Augmentation Systems | 10 |
| 1.10.1 Differential GNSS (DGNSS) | 10 |
| 1.11 Data logging..... | 10 |
| 1.12 Host Interface Signature..... | 10 |
| 1.13 Geofencing..... | 10 |
| 1.14 TIMEPULSE..... | 11 |
| 1.15 Protocols and interfaces | 11 |
| 1.16 Interfaces..... | 11 |
| 1.16.1 UART..... | 11 |
| 1.16.2 USB..... | 12 |
| 1.16.3 SPI..... | 12 |
| 1.16.4 Display Data Channel (DDC)..... | 12 |
| 1.17 EXTINT: External interrupt | 12 |
| 1.18 Clock generation | 12 |
| 1.18.1 Oscillators..... | 12 |
| 1.18.2 Real-Time Clock (RTC)..... | 12 |
| 1.19 Power management..... | 12 |
| 1.19.1 Power control..... | 13 |
| 1.20 Antenna..... | 13 |
| 2 Pin Definition..... | 14 |

| | | |
|--------------------------|---|-----------|
| 2.1 | Pin assignment | 14 |
| 3 | Configuration management | 15 |
| 3.1 | Interface Selection (D_SEL)..... | 15 |
| 4 | Electrical specification | 16 |
| 4.1 | Absolute maximum rating | 16 |
| 4.2 | Operating conditions | 17 |
| 4.3 | Indicative current requirements..... | 17 |
| 4.4 | SPI timing diagrams..... | 18 |
| 4.4.1 | Timing recommendations..... | 18 |
| 4.5 | DDC timing | 18 |
| 5 | Mechanical specifications | 19 |
| 6 | Reliability tests and approvals | 20 |
| 6.1 | Reliability tests | 20 |
| 6.2 | Approvals | 20 |
| 7 | Product handling & soldering..... | 21 |
| 7.1 | Packaging..... | 21 |
| 7.1.1 | Reels | 21 |
| 7.1.2 | Tapes | 21 |
| 7.2 | Shipment, storage and handling..... | 22 |
| 7.2.1 | Moisture Sensitivity Levels | 22 |
| 7.2.2 | Reflow soldering | 22 |
| 7.2.3 | ESD handling precautions..... | 22 |
| 8 | Default messages | 23 |
| 9 | Labeling and ordering information..... | 24 |
| 9.1 | Product labeling..... | 24 |
| 9.2 | Explanation of codes | 24 |
| 9.3 | Ordering codes..... | 24 |
| Appendix | | 25 |
| Glossary | | 25 |
| Related documents | | 26 |
| Revision history | | 26 |
| Contact | | 27 |

1 Functional description

1.1 Overview

The NEO-M8P modules combine the high performance u-blox M8 positioning engine with u-blox's Real Time Kinematic (RTK) technology. The NEO-M8P provides cm-level GNSS performance designed to meet the needs of unmanned vehicles and other machine control applications requiring accurate guidance.

u-blox's RTK technology introduces the concept of a "rover" (NEO-M8P-0) and a "base" (NEO-M8P-2) on the M8 platform for stunning cm-level accuracy in clear sky environments. The base module sends corrections via the RTCM protocol to the rover module via a communication link enabling the rover to output its position relative to the base at cm level accuracies.

The NEO-M8P is ideal for applications requiring vehicles to move faster and more accurately, operate without physical boundaries (e.g. wires or fences), and automatically return to base platforms. Such applications include UAV, unmanned vehicles (e.g. robotic lawn mowers), and Precision Agriculture guidance.

The NEO-M8P modules enable the system integrator to access u-blox's complete end-to-end RTK solution including the stationary "survey-in" and the moving base station functionalities that are designed to reduce the setup time and increase the flexibility of the application. NEO-M8P modules are compatible with a wide range of communication technologies (Cellular, WiFi, Bluetooth, UHF) enabling the user to select the communication link best suited to their application. With u-blox's RTK technology, integration and software development efforts can be reduced, ensuring a minimal cost of ownership.

u-blox M8 modules use GNSS chips qualified according to AEC-Q100, are manufactured in ISO/TS 16949 certified sites, and fully tested on a system level. Qualification tests are performed as stipulated in the ISO16750 standard: "Road vehicles – Environmental conditions and testing for electrical and electronic equipment".

u-blox's AssistNow Assistance services supply aiding information, such as ephemeris, almanac and time, reducing the time to first fix significantly and improving acquisition sensitivity. The NEO-M8P operates with the AssistNow Online service which provides current GNSS constellation orbit data to allow a Time To First Fix in seconds.

1.2 Product features

| Model | Category | GNSS | | | | Supply | Interfaces | Features | | | | | | | | Grade |
|-----------|--|--|---------------------------|---------------|--|---|--|----------|--|--|--|--|--|--|--|-------|
| | Standard Precision GNSS High Precision GNSS Dead Reckoning Timing | GPS / QZSS GLONASS Galileo BeiDou | Number of Concurrent GNSS | 2.7 V – 3.6 V | UART USB SPI DDC (I ² C compliant) | Programmable (Flash) Data logging Carrier phase output Additional SAW Additional LNA RTK rover Base station with survey-in Timepulse | Standard Professional Automotive | | | | | | | | | |
| NEO-M8P-0 | • | • • | 2 | • | • • • • | • • • • • • • • | 1 | | | | | | | | | |
| NEO-M8P-2 | • | • • | 2 | • | • • • • | • • • • • • • • | 1 | | | | | | | | | |

1.3 Performance

| Parameter | Specification | | |
|---|---|----------------------------------|-------------------|
| Receiver type | u-blox M8 engine GPS L1C/A GLONASS L1OF | | |
| | | GPS & GLONASS | GPS |
| Time-To-First-Fix ¹ | Cold start | 26 s | 29 s |
| | Hot start | 1 s | 1 s |
| | Aided starts ² | 2 s | 2 s |
| Sensitivity ³ | Tracking & Navigation ⁴ | -160 dBm | -160 dBm |
| | Reacquisition | -158 dBm | -158 dBm |
| | Cold start | -148 dBm | -148 dBm |
| | Warm start | -156 dBm | -156 dBm |
| Max navigation update rate | RTK | 2 Hz | 5 Hz ⁵ |
| | PVT | 5 Hz | 10 Hz |
| | RAW | 10 Hz | |
| Convergence Time ⁶ | RTK | 3 min | |
| Heading accuracy ⁷ | | 0.3 degrees | |
| Horizontal position accuracy ⁶ | Standalone | 2.5 m CEP | |
| | RTK ⁷ | 0.025 m + 1 ppm CEP | |
| Accuracy of time pulse signal | RMS | 30 ns | |
| | 99% | 60 ns | |
| Frequency of time pulse signal | | 0.25 Hz... 10 MHz (configurable) | |
| Operational limits ⁸ | Dynamics | ≤ 4 g | |
| | Altitude | 50,000 m | |
| | Velocity | 500 m/s | |

Table 1: NEO-M8P performance in different GNSS modes (default: concurrent reception of GPS and GLONASS)

¹ All satellites at -130 dBm

² Dependent on aiding data connection speed and latency

³ Demonstrated with a good external LNA

⁴ Limited by FW for best performance

⁵ Limited to 2 Hz with current FW (HPG1.00) release

⁶ Depends on atmospheric conditions, baseline length, GNSS antenna, multipath conditions satellite visibility and geometry

⁷ ppm limited to baselines up to 10 km

⁸ Assuming Airborne < 4 g platform

1.4 Block diagram

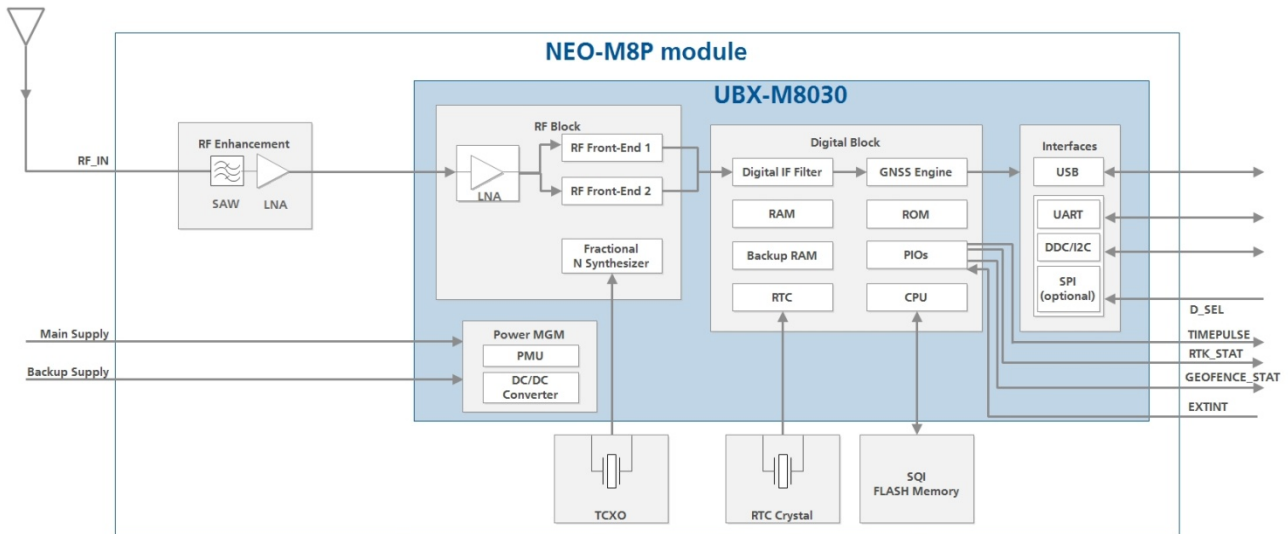

Figure 1: NEO-M8P block diagram

1.5 GNSS

The NEO-M8P positioning modules are concurrent GNSS receivers and can receive and track multiple GNSS systems. NEO-M8P receivers are configured by default for concurrent GPS and GLONASS reception. Both constellations can be used in an RTK solution, however if RTK update rate is a key factor, the receiver should be configured for GPS only

1.5.1 GPS

The NEO-M8P positioning modules are designed to receive and track the L1C/A signals provided at 1575.42 MHz by the Global Positioning System (GPS).

1.5.2 GLONASS

The NEO-M8P positioning modules can receive and process GLONASS concurrently with GPS. The Russian GLONASS satellite system is an alternative system to the US-based Global Positioning System (GPS). The NEO-M8P modules are designed to receive and track the L1OF signals GLONASS provides at $1602 \text{ MHz} + k \cdot 562.5 \text{ kHz}$, where k is the satellite's frequency channel number ($k = -7, -6, \dots, 5, 6$). The ability to receive and track GLONASS L1OF satellite signals allows design of GLONASS receivers where required by regulations.

1.6 Rover navigation modes

1.6.1 Operation

In its default configuration the NEO-M8P Rover will attempt to provide the best positioning accuracy dependant on the received correction data. It will enter RTK Float mode as soon as it receives an input stream of RTCM 3 messages. Once the Rover has resolved the carrier phase ambiguities it will go into an RTK Fixed mode. It is when the Rover is in RTK Fixed mode that the relative accuracies can be expected to be correct to the cm-level.

It will typically take up to 3 minutes before the Rover has been able to solve the carrier ambiguities and go from RTK Float mode to RTK Fixed mode. The length of this time period is referred to as the *Convergence time*.

The Rover will drop back to RTK Float mode if it loses carrier phase lock on the minimum amount of signals needed to maintain RTK Fixed mode. The Rover will continue to attempt to resolve carrier ambiguities and go back to the RTK Fixed mode once the minimum number of signals has been restored.

If RTCM 3 corrections become unavailable, the rover will run as a standard PVT receiver.

The current operation mode is indicated by relevant NMEA and UBX-NAV messages; see the *u-blox 8 / u-blox M8 Receiver Description Including Protocol Specification* [2], [3] for the individual message details.

When the module receives a valid stream of RTCM 3 messages the **RTK_STAT** status pin is set into an alternating, blinking mode. The **RTK_STAT** status pin is set active low when the Rover module is operating in RTK Fixed mode.

1.6.2 RTK Operation

Under RTK operation the M8P modules operate as a pair consisting of a Rover and a Base to enable high precision carrier phase positioning. The Rover needs access to an observation message stream of RTCM 3 messages before it can enter RTK mode and before cm level accuracies can be reached. The various concepts are explained in detail below.

1.6.2.1 Relative and absolute position

In RTK mode the NEO-M8P-0 Rover module calculates its position *relative* to the location of the Base position. The relative accuracy can at best be correct to the centimeter level. To get an accuracy that is optimal in an absolute sense the accuracy of the Base station position must be optimized. In the UBX-NAV message, the relative position is described in the form of a NED vector.

The absolute accuracy of the Base station position will be transferred to the absolute accuracy of a Rover operating in differential mode. The NEO-M8P-2 Base station module comes with functionalities to ensure the best possible absolute accuracy as described in section 1.7.

1.7 Base station modes (NEO-M8P-2)

By default the Base station device will begin operation in standard mode without any correction stream output. The NEO-M8P-2 can be set to use previously surveyed coordinates of the Base antenna position or set to survey in its location. The RTCM correction stream will only be outputted after these modes are successfully set.

1.7.1 Fixed stationary mode

The NEO-M8P-2 can be set to use previously surveyed coordinates of the Base antenna position. Assuming such coordinates are of highest quality, this method ensures the best absolute accuracy for the Rover units. The device will output RTCM 3 messages when configured in this mode.

This mode is set by using the command UBX-CFG-TMODE3 with receiver mode flag "Fixed Mode". The input coordinates can be given in LAT/LON/ALT or ECEF, WGS84.

 For more details see the *u-blox 8 / u-blox M8 Receiver Description Including Protocol Specification [2]* and *[3]*.

1.7.2 Survey-in function for fixed stationary mode

The NEO-M8P-2 is capable to self survey-in its coordinates in situations where the Base antenna is not surveyed using other means, but when the Base antenna can be expected to be (typically) static. When this mode is configured the user provides a constraint on accuracy with a maximum observation time in which to average its position estimates. If it meets the accuracy constraint, the Base will begin operating in a fixed stationary mode and output a RTCM 3 message stream.

This mode is set by using the command `UBX-CFG-TMODE3` with receiver mode flag "Survey In". The input coordinates can be given in LAT/LON/ALT or ECEF, WGS84.

 For more details see the *u-blox 8 / u-blox M8 Receiver Description Including Protocol Specification [2]* and *[3]*.

1.7.3 Communication link

 The communication link from the Base to the Rover must be reliable. Breaks in this communication will result in the Rover solution degrading, and eventually falling back to a PVT type of navigation fix, depending on configuration setting. The RTCM messages output from the Base are by default configured to the recommended 1 Hz output rate. Corrections for both GPS and GLONASS at this rate will amount to a load of approximately 3 kbps (assuming an update rate of 1Hz reporting 20 GPS/GLONASS satellites with MSM7 corrections).

1.8 Raw Data

The NEO-M8P modules provide raw measurement data for civil L1 band GPS and GLONASS signals including pseudo-range and carrier phase, carrier Doppler frequency and message payloads. The data contained in the `UBX-RXM-RAWX` message follows the conventions of a multi-GNSS RINEX 3 observation file and includes pseudo-range, carrier phase and Doppler measurements along with measurement quality data. The `UBX-RXM-SFRBX` message provides the demodulated, parity-checked navigation and signaling message bits for each satellite currently tracked by the receiver.

Raw measurement data are available once the receiver has established data bit synchronization and time-of-week. Message data are available for all signals tracked at a sufficient level to achieve data bit and frame synchronization. For more information see the *u-blox 8 / u-blox M8 Receiver Description Including Protocol Specification [2]*, *[3]*.

1.9 Assisted GNSS (A-GNSS)

Supply of aiding information, such as ephemeris, almanac, approximate position and time, will reduce the time to first fix significantly and improve the acquisition sensitivity. The NEO-M8P products support the u-blox AssistNow Online and are OMA SUPL compliant.

1.9.1 AssistNow™ Online

With AssistNow Online, an internet-connected GNSS device downloads assistance data from u-blox's AssistNow Online Service at system start-up. AssistNow Online is network-operator independent and globally available. Devices can be configured to request only ephemeris data for those satellites currently visible at their location, thus minimizing the amount of data transferred.

 For more details see the *u-blox 8 / u-blox M8 Receiver Description Including Protocol Specification [2]*, *[3]* and *MGA Services User Guide [6]*.

1.10 Augmentation Systems

1.10.1 Differential GNSS (DGNSS)

When operating in RTK mode RTCM version 3 messages are required and the NEO-M8P supports DGNSS according to RTCM 10403.2 [7]. The RTCM implementation in the rover and base-station variants provides decoding of the following RTCM 3.2 messages:

| Message Type | Description |
|--------------|-----------------------------|
| 1001 | GPS L1 observations |
| 1002 | GPS L1 observations |
| 1003 | GPS L1/L2 observations |
| 1004 | GPS L1/L2 observations |
| 1005 | Station coordinates |
| 1006 | Station coordinates |
| 1007 | Station Antenna Information |
| 1009 | GLONASS L1 observations |
| 1010 | GLONASS L1 observations |
| 1011 | GLONASS L1/L2 observations |
| 1012 | GLONASS L1/L2 observations |
| 1075 | MSM5 GPS observations |
| 1077 | MSM7 GPS observations |
| 1085 | MSM5 GLONASS observations |
| 1087 | MSM7 GLONASS observations |

Table 2: Supported decoding of RTCM 3.2 messages

The RTCM implementation in the base station (NEO-M8P-2) generates the following RTCM 3.2 output messages:

| Message Type | Description |
|--------------|---------------------------|
| 1005 | Station coordinates |
| 1077 | MSM7 GPS observations |
| 1087 | MSM7 GLONASS observations |

Table 3: Supported encoding of RTCM 3.2 messages

1.11 Data logging

The u-blox NEO-M8P receivers can be used in data logging applications. The data logging feature enables continuous storage of position, velocity and time information to an onboard SPI flash memory. It can also log distance from an odometer function. The logged data can be downloaded from the receiver later for further analysis or for conversion to a mapping tool. For more information see the *u-blox 8 / u-blox M8 Receiver Description Including Protocol Specification* [2], [3].

1.12 Host Interface Signature

The host interface signature mechanism provides protection against unauthorized tampering of the message data sent from the receiver to its host. This increases the robustness of the system against alteration of position and/or time information sent from the receiver (i.e. UART). Nominated messages are effectively 'signed' by the receiver using a hashing algorithm to generate a signature message for subsequent checking at the host. A dynamic 'seeding' of the algorithm can be used to detect time shifted replay attacks on the received message data. See *u-blox 8 / u-blox M8 Receiver Description Including Protocol Specification* [2], [3] for more information.

1.13 Geofencing

The geofencing feature allows for the configuration of up to four circular areas (geofences) on the earth's surface. The receiver will then evaluate for each of these areas whether the current position lies within the area

or not and signal the state via UBX messaging and PIO toggling. Geofencing can be configured using the UBX-CFG-GEOFENCE message; the geofence evaluation is active whenever there is at least one geofence configured. The NEO-M8P module uses pin 16 as the **GEOFENCE_STAT** status pin. This is asserted active low to indicate any position within the combined geofence areas.

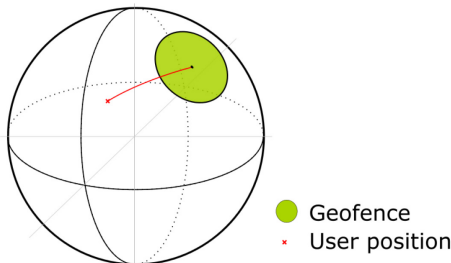

Figure 2: Illustration of the Geofence boundary

1.14 TIMEPULSE

A configurable time pulse signal is available with the NEO-M8P modules.

The TIMEPULSE output generates pulse trains synchronized with a GPS or UTC time grid with intervals configurable over a wide frequency range. Thus it may be used as a low frequency time synchronization pulse or as a high frequency reference signal.

The NEO-M8P time pulse output is configured using messages for "TIMEPULSE2." This pin has a secondary function during start-up (initiation of "SAFEBOOT" mode for firmware recovery) and should not normally be held LO during start-up.

By default the time pulse signal is disabled and if required can be activated using UBX-CFG-TP5. For more information see the *u-blox 8 / u-blox M8 Receiver Description including Protocol Specification* [2], [3].

1.15 Protocols and interfaces

| Protocol | Type |
|--|--|
| NMEA 0183 V4.0 (V2.1, V2.3 and V4.1 configurable) | Input/output, ASCII |
| UBX | Input/output, binary, u-blox proprietary |
| RTCM 3.2 | Input, for RTK |
| RTCM 3.2 | Output (NEO-M8P-2 only) |

Table 4: Available Protocols

All protocols are available on UART, USB, DDC (I²C compliant) and SPI. For specification of the various protocols see the *u-blox 8 / u-blox M8 Receiver Description Including Protocol Specification* [2], [3].

When NMEA protocol is used, version V4.1 is needed to provide all the related RTK information flags.

1.16 Interfaces

A number of interfaces are provided either for data communication or memory access. The embedded firmware uses these interfaces according to their respective protocol specifications.

1.16.1 UART

The NEO-M8P modules include one UART interface, which can be used for communication to a host. It supports configurable baud rates. For supported baud rates see the *u-blox 8 / u-blox M8 Receiver Description Including Protocol Specification* [2], [3].



Designs must allow access to the UART and the **SAFEBOOT_N** function pin for future service, updates and reconfiguration.

1.16.2 USB

A USB version 2.0 FS compatible interface can be used for communication as an alternative to the UART. The pull-up resistor on pin USB_DP is integrated to signal a full-speed device to the host. The VDD_USB pin supplies the USB interface.

u-blox offers USB drivers for use with Windows operating systems. For Windows 7, 8 and 10 there is a sensor driver for users who wish to connect to the Windows sensor platform. For users who wish to connect multiple devices or require a virtual com port, Windows 10 users can use the built-in driver, otherwise u-blox provide a standard USB driver (CDC-ACM) for Windows Vista and Windows 7 and 8. Windows drivers can be downloaded from the u-blox.com web site.

1.16.3 SPI

The SPI interface is designed to allow communication to a host CPU. The interface can be operated in slave mode only. The maximum transfer rate using SPI is 1 Mb/s and the maximum SPI clock frequency is 5.5 MHz. Note that SPI is not available in the default configuration, because its pins are shared with the UART and DDC interfaces. The SPI interface can be enabled by connecting D_SEL (Pin 2) to ground (see section 3.1).

1.16.4 Display Data Channel (DDC)

An I²C compliant DDC interface is available for communication with an external host CPU or u-blox cellular modules. The interface can be operated in slave mode only. The DDC protocol and electrical interface are fully compatible with Fast-Mode of the I²C industry standard. Since the maximum SCL clock frequency is 400 kHz, the maximum transfer rate is 400 kb/s.

1.17 EXTINT: External interrupt

EXTINT is an external interrupt pin with fixed input voltage thresholds with respect to VCC. It can be used for control of the receiver or for aiding.

For more information about how to implement and configure these features, see the *u-blox 8 / u-blox M8 Receiver Description including Protocol Specification* [2], [3] and the *NEO-M8P Hardware Integration Manual* [1].

1.18 Clock generation

1.18.1 Oscillators

The NEO-M8P GNSS modules incorporate a TCXO for accelerated weak signal acquisition, faster start and reacquisition. These TCXOs are carefully selected and screened for stability and against frequency perturbations across the full operating range (−40° to +85°C).

1.18.2 Real-Time Clock (RTC)

The RTC is driven by a 32 kHz oscillator using an RTC crystal. If the main supply voltage fails, and a battery is connected to V_BCKP, parts of the receiver switch off, but the RTC still runs providing a timing reference for the receiver. This operating mode is called Hardware Backup Mode, which enables all relevant data to be saved in the backup RAM to allow a hot or warm start later.

1.19 Power management

u-blox M8 technology offers a power-optimized architecture with built-in autonomous power saving functions to minimize power consumption at any given time. In addition, a high efficiency DC/DC converter is integrated for lower power consumption and reduced power dissipation.



For more details see the *u-blox 8 / u-blox M8 Receiver Description Including Protocol Specification* [2], [3].

1.19.1 Power control

A separate battery backup voltage may be applied to the module to retain the current state of the receiver and sustain a low power real time clock (RTC) while the main supply is removed. This enables faster acquisition and navigation upon start-up.

Alternatively, a configuration command (UBX-CFG-PWR) can be issued to stop the receiver in a similar way to Hardware Backup Mode (see 1.18.2 above) whilst the main supply remains active. This mode is referred to as Software backup mode; current consumption in this mode is slightly higher than in Hardware Backup Mode. The receiver will then restart on the next edge received at its UART interface (there will be a delay before any communications are possible).

See Table 10 for current consumption in backup modes.

1.20 Antenna

u-blox recommend use of an active antenna⁹ or external LNA with this module to achieve best performance.

| Parameter | Specification | |
|--------------------------------|---------------------------|---|
| Antenna Type | Active or passive antenna | |
| Active Antenna Recommendations | Minimum gain | 15 dB (to compensate signal loss in RF cable) |
| | Maximum gain | 50 dB |
| | Maximum noise figure | 1.5 dB |

Table 5: Antenna Specifications for the NEO-M8P modules

The antenna system should include filtering to ensure adequate protection from nearby transmitters. Care should be taken in the selection of antennas placed closed to cellular or WiFi transmitting antennas.



For guidance on antenna selection see the *NEO-M8P Hardware Integration Manual* [1].

⁹ For information on using active antennas with NEO-M8P modules, see the *NEO-M8P Hardware Integration Manual* [1].

2 Pin Definition

2.1 Pin assignment

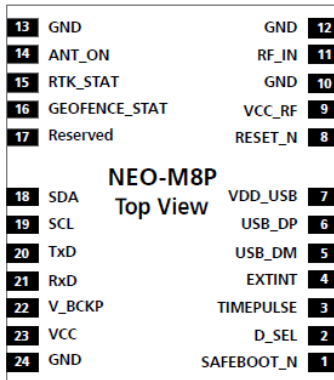

Figure 3: Pin Assignment

| No | Name | I/O | Description |
|----|-----------------|-----|--|
| 1 | SAFEBOOT_N | I | SAFEBOOT_N (for future service, updates and reconfiguration, leave OPEN) |
| 2 | D_SEL | I | Interface select |
| 3 | TIMEPULSE | O | Time pulse (1PPS) |
| 4 | EXTINT | I | External Interrupt Pin |
| 5 | USB_DM | I/O | USB Data |
| 6 | USB_DP | I/O | USB Data |
| 7 | VDD_USB | I | USB Supply |
| 8 | RESET_N | I | RESET_N |
| 9 | VCC_RF | O | Output Voltage RF section |
| 10 | GND | I | Ground |
| 11 | RF_IN | I | GNSS signal input |
| 12 | GND | I | Ground |
| 13 | GND | I | Ground |
| 14 | ANT_ON | O | Antenna control |
| 15 | RTK_STAT | O | RTK status 0 – Fixed, blinking – receiving RTCM data, 1 – no corrections |
| 16 | GEOFENCE_STAT | O | Geofence status, user defined |
| 17 | Reserved | - | Reserved |
| 18 | SDA SPI CS_N | I/O | DDC Data if D_SEL =1 (or open) SPI Chip Select if D_SEL = 0 |
| 19 | SCL SPI CLK | I/O | DDC Clock if D_SEL =1(or open) SPI Clock if D_SEL = 0 |
| 20 | TxD SPI MISO | O | Serial Port if D_SEL =1(or open) SPI MISO if D_SEL = 0 |
| 21 | RxD SPI MOSI | I | Serial Port if D_SEL =1(or open) SPI MOSI if D_SEL = 0 |
| 22 | V_BCKP | I | Backup voltage supply |
| 23 | VCC | I | Supply voltage |
| 24 | GND | I | Ground |

Table 6: Pinout



Pins designated Reserved should not be used. For more information about Pinouts see the *NEO-M8P Hardware Integration Manual [1]*.

3 Configuration management

Configuration settings can be modified with UBX configuration messages. The modified settings remain effective until power-down or reset. Settings can also be saved in battery-backed RAM, Flash or both using the UBX-CFG-CFG message. If settings have been stored in battery-backed RAM then the modified configuration will be retained as long as the backup battery supply at V_BCKP is not interrupted. Settings stored in Flash memory will remain effective even after power-down and do not require a backup battery supply.

3.1 Interface Selection (D_SEL)

At startup, Pin 2 (D_SEL) determines which data interfaces are used for communication. If D_SEL is set high or left open, UART and DDC become available. If D_SEL is set low, i.e. connected to ground, the NEO-M8P module can communicate to a host via SPI.

| PIN # | D_SEL="1" (left open) | D_SEL = "0" (connected to GND) |
|-------|--------------------------|-----------------------------------|
| 20 | UART TX | SPI MISO |
| 21 | UART RX | SPI MOSI |
| 19 | DDC SCL | SPI CLK |
| 18 | DDC SDA | SPI CS_N |

Table 7: Data interface selection by D_SEL

4 Electrical specification



The limiting values given are in accordance with the Absolute Maximum Rating System (IEC 134). Stress above one or more of the limiting values may cause permanent damage to the device. These are stress ratings only and operation of the device at these or at any other conditions above those given in the characteristics sections of the specification is not implied. Exposure to these limits for extended periods may affect device reliability.



Where application information is given, it is advisory only and does not form part of the specification. For more information see the *NEO-M8P Hardware Integration Manual [1]*.

4.1 Absolute maximum rating

| Parameter | Symbol | Condition | Min | Max | Units |
|--|---------------------|--|------|---------|-------|
| Power supply voltage | VCC | | -0.5 | 3.6 | V |
| Backup battery voltage | V_BCKP | | -0.5 | 3.6 | V |
| USB supply voltage | VDD_USB | | -0.5 | 3.6 | V |
| Input pin voltage | V _{in} | | -0.5 | 3.6 | V |
| | V _{in_usb} | | -0.5 | VDD_USB | V |
| | V _{rfin} | | 0 | 6 | V |
| DC current through any digital I/O pin (except supplies) | I _{pin} | | | 10 | mA |
| VCC_RF output current | ICC_RF | | | 100 | mA |
| Input power at RF_IN | P _{rfin} | source impedance = 50 Ω, continuous wave | | 15 | dBm |
| Storage temperature | T _{stg} | | -40 | 85 | °C |

Table 8: Absolute maximum ratings



Stressing the device beyond the “Absolute Maximum Ratings” may cause permanent damage. These are stress ratings only. The product is not protected against overvoltage or reversed voltages. If necessary, voltage spikes exceeding the power supply voltage specification, given in table above, must be limited to values within the specified boundaries by using appropriate protection diodes.

4.2 Operating conditions

All specifications are at an ambient temperature of 25°C. Extreme operating temperatures can significantly impact specification values. Applications operating near the temperature limits should be tested to ensure the specification.

| Parameter | Symbol | Min | Typical | Max | Units | Condition |
|---|----------|---|---------|---------|-------|------------------------------|
| Power supply voltage | VCC | 2.7 | 3.0 | 3.6 | V | |
| Supply voltage USB | VDD_USB | 3.0 | 3.3 | 3.6 | V | |
| Backup battery voltage | V_BCKP | 1.4 | | 3.6 | V | |
| Backup battery current | I_BCKP | | 15 | | μA | V_BCKP = 1.8 V, VCC = 0 V |
| SW backup current | I_SWBCKP | | 30 | | μA | VCC = 3 V |
| Input pin voltage range | Vin | 0 | | VCC | V | |
| Digital IO Pin Low level input voltage | Vil | 0 | | 0.2*VCC | V | |
| Digital IO Pin High level input voltage | Vih | 0.7*VCC | | VCC | V | |
| Digital IO Pin Low level output voltage | Vol | | | 0.4 | V | Iol = 4 mA |
| Digital IO Pin High level output voltage | Voh | VCC-0.4 | | | V | Ioh = 4 mA |
| Pull-up resistor for RESET_N | Rpu | | 11 | | kΩ | |
| USB_DM, USB_DP | VinU | Compatible with USB with 27 Ω series resistance | | | | |
| VCC_RF voltage | VCC_RF | | VCC-0.1 | | V | |
| VCC_RF output current | ICC_RF | | | 50 | mA | |
| Receiver Chain Noise Figure ¹⁰ | NFtot | | 3 | | dB | |
| Operating temperature | Topr | -40 | | 85 | °C | |

Table 9: Operating conditions

Operation beyond the specified operating conditions can affect device reliability.

4.3 Indicative current requirements

Table 11 lists examples of the total system supply current for a possible application.

Values in Table 10 are provided for customer information only as an example of typical power requirements. Values are characterized on samples, actual power requirements can vary depending on firmware version used, external circuitry, number of satellites tracked, signal strength, type of start as well as time, duration and conditions of test.

| Parameter | Symbol | Typ GPS & GLONASS | Typ GPS | Max | Units | Condition |
|--|-----------------------------------|----------------------|------------|-----|-------|------------------|
| Max. supply current ¹¹ | Iccp | | | 67 | mA | |
| Average supply current ^{12, 13} | Icc Acquisition ¹⁴ | 35 | 27 | | mA | Estimated at 3 V |
| | Icc Tracking (Continuous mode) | 33 | 25 | | mA | Estimated at 3 V |

Table 10: Indicative power requirements at 3.0 V

For more information about power requirements, see the *NEO-M8P Hardware Integration Manual* [1].

For more information on how to noticeably reduce current consumption, see the *Power Management Application Note* [5].

¹⁰ Only valid for the GPS band

¹¹ Use this figure to dimension maximum current capability of power supply. Measurement of this parameter with 1 Hz bandwidth.

¹² Use this figure to determine required battery capacity.

¹³ Simulated GNSS constellation using power levels of -130 dBm. VCC = 3.0 V

¹⁴ Average current from start-up until the first fix.

4.4 SPI timing diagrams

In order to avoid incorrect operation of the SPI, the user needs to comply with certain timing conditions. The following signals need to be considered for timing constraints:

| Symbol | Description |
|-----------------|---------------------|
| SPI CS_N (SS_N) | Slave select signal |
| SPI CLK (SCK) | Slave clock signal |

Table 11: Symbol description

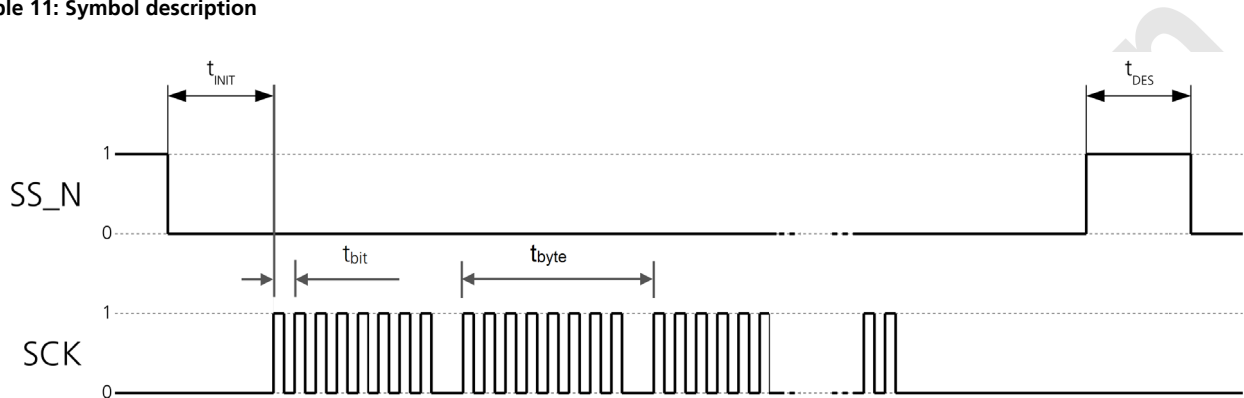

Figure 4: SPI timing diagram

4.4.1 Timing recommendations

The recommendations below are based on a firmware running from Flash memory.

| Parameter | Description | Recommendation |
|------------|---------------------|--|
| t_{INIT} | Initialization Time | >10 μ s |
| t_{DES} | Deselect Time | 1 ms |
| t_{bit} | Minimum bit time | 180 ns (5.5 MHz max bit frequency) |
| t_{byte} | Minimum byte period | 8 μ s (125 kHz max byte frequency) |

Table 12: SPI timing recommendations

The values in the above table result from the requirement of an error-free transmission. For more information see the *u-blox 8 / u-blox M8 Receiver Description Including Protocol Specification [2], [3]*.

4.5 DDC timing

The DDC interface is I²C Fast Mode compliant. For timing parameters consult the I²C standard.

The maximum bit rate is 400 kb/s. The interface stretches the clock when slowed down when serving interrupts, so real bit rates may be slightly lower.

5 Mechanical specifications

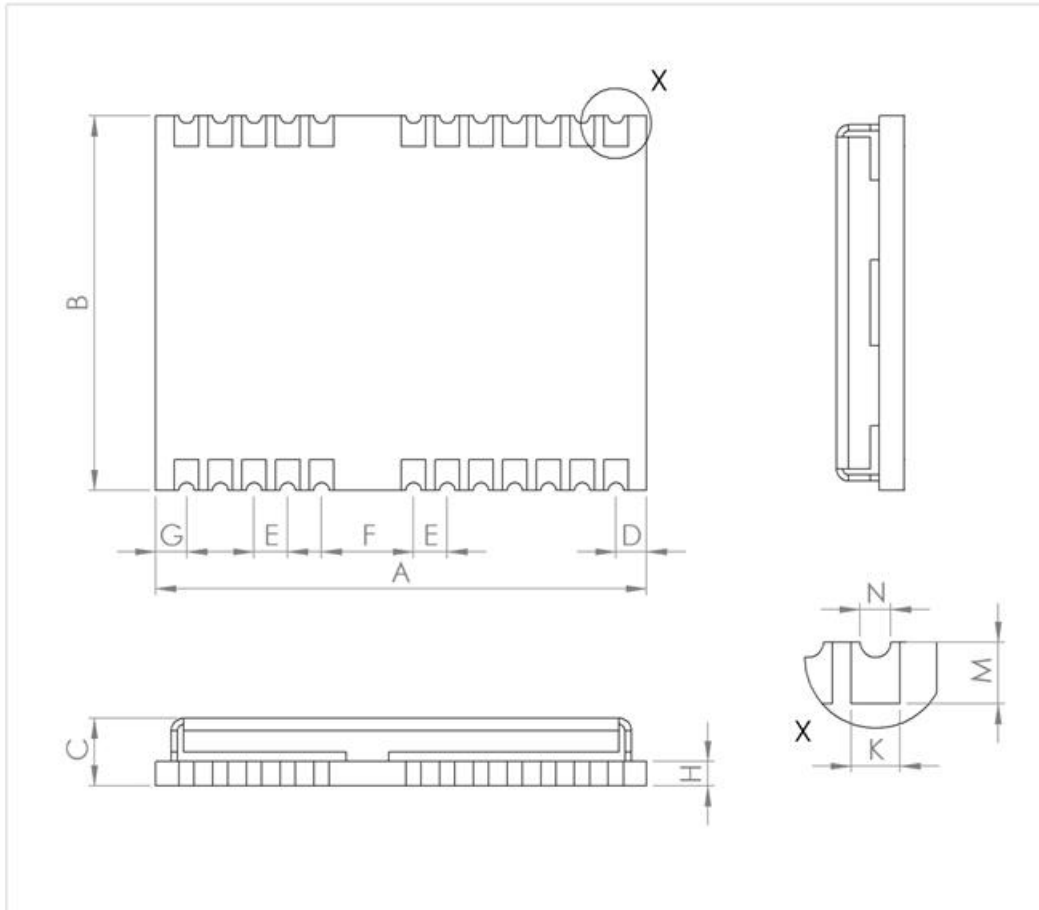

| Symbol | Min. (mm) | Typ. (mm) | Max. (mm) |
|--------|-----------|-----------|-----------|
| A | 15.9 | 16.0 | 16.6 |
| B | 12.1 | 12.2 | 12.3 |
| C | 2.2 | 2.4 | 2.6 |
| D | 0.9 | 1.0 | 1.3 |
| E | 1.0 | 1.1 | 1.2 |
| F | 2.9 | 3.0 | 3.1 |
| G | 0.9 | 1.0 | 1.3 |
| H | | 0.82 | |
| K | 0.7 | 0.8 | 0.9 |
| M | 0.8 | 0.9 | 1.0 |
| N | 0.4 | 0.5 | 0.6 |
| Weight | | 1.6g | |

Figure 5: Dimensions



For information about the paste mask and footprint, see the *NEO-M8P Hardware Integration Manual* [1].

6 Reliability tests and approvals

6.1 Reliability tests



The NEO-M8P modules are based on AEC-Q100 qualified GNSS chips.

Tests for product family qualifications are according to ISO 16750 "Road vehicles – environmental conditions and testing for electrical and electronic equipment", and appropriate standards.

6.2 Approvals



Products marked with this lead-free symbol on the product label comply with the "Directive 2002/95/EC of the European Parliament and the Council on the Restriction of Use of certain Hazardous Substances in Electrical and Electronic Equipment" (RoHS).

All u-blox M8 GNSS modules are RoHS compliant.

7 Product handling & soldering

7.1 Packaging

The NEO-M8P GNSS modules are delivered as hermetically sealed, reeled tapes in order to enable efficient production, production lot set-up and tear-down. For more information see the *u-blox Package Information Guide* [4].

7.1.1 Reels

The NEO-M8P GNSS modules are deliverable in quantities of 250 pcs on a reel. The NEO-M8P receivers are shipped on Reel Type B, as specified in the *u-blox Package Information Guide* [4].

7.1.2 Tapes

The dimensions and orientations of the tapes for NEO-M8P GNSS modules are specified in Figure 6.

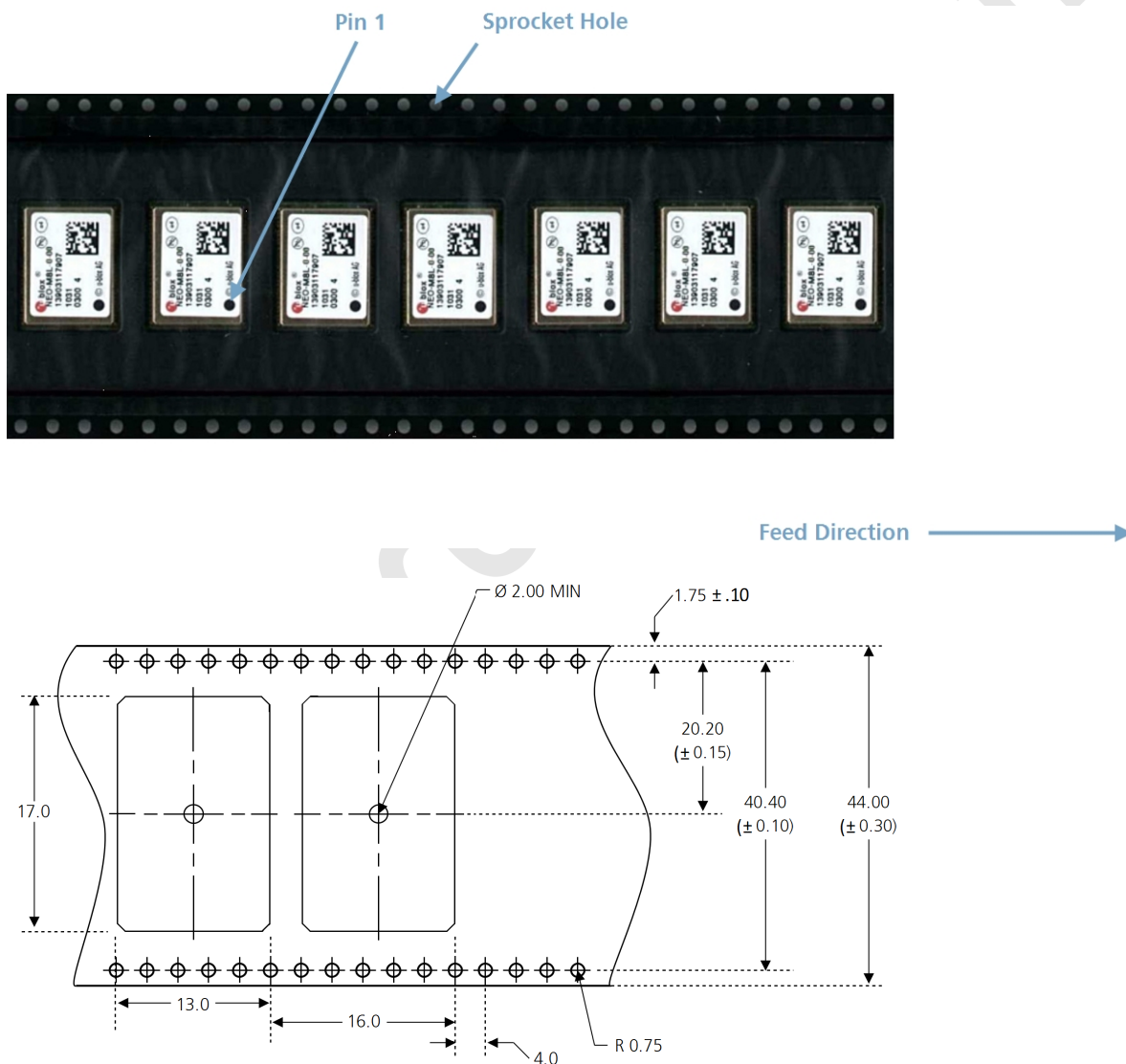

Figure 6: Dimensions and orientation for NEO-M8P modules on tape

7.2 Shipment, storage and handling

For important information regarding shipment, storage and handling see the *u-blox Package Information Guide* [4].

7.2.1 Moisture Sensitivity Levels

The Moisture Sensitivity Level (MSL) relates to the packaging and handling precautions required. The NEO-M8P modules are rated at MSL level 4.



For MSL standard see IPC/JEDEC J-STD-020, which can be downloaded from www.jedec.org.

For more information regarding MSL see the *u-blox Package Information Guide* [4].

7.2.2 Reflow soldering

Reflow profiles are to be selected according u-blox recommendations (see the *NEO-M8P Hardware Integration Manual* [1]).

7.2.3 ESD handling precautions

NEO-M8P modules are Electrostatic Sensitive Devices (ESD). Observe precautions for handling! Failure to observe these precautions can result in severe damage to the GNSS receiver!

GNSS receivers are Electrostatic Sensitive Devices (ESD) and require special precautions when handling. Particular care must be exercised when handling patch antennas, due to the risk of electrostatic charges. In addition to standard ESD safety practices, the following measures should be taken into account whenever handling the receiver:

- Unless there is a galvanic coupling between the local GND (i.e. the work table) and the PCB GND, then the first point of contact when handling the PCB must always be between the local GND and PCB GND.
- Before mounting an antenna patch, connect ground of the device
- When handling the RF pin, do not come into contact with any charged capacitors and be careful when contacting materials that can develop charges (e.g. patch antenna ~10 pF, coax cable ~50-80 pF/m, soldering iron, ...)
- To prevent electrostatic discharge through the RF input, do not touch any exposed antenna area. If there is any risk that such exposed antenna area is touched in non ESD protected work area, implement proper ESD protection measures in the design.
- When soldering RF connectors and patch antennas to the receiver's RF pin, make sure to use an ESD safe soldering iron (tip).

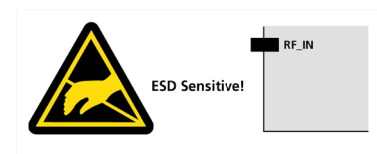

8 Default messages

| Interface | Settings |
|-------------|---|
| UART Output | 9600 Baud, 8 bits, no parity bit, 1 stop bit Configured to transmit both NMEA and UBX protocols, but only the following NMEA (and no UBX) messages have been activated at start-up: GGA, GLL, GSA, GSV, RMC, VTG, TXT |
| USB Output | Configured to transmit both NMEA and UBX protocols, but only the following NMEA (and no UBX) messages have been activated at start-up: GGA, GLL, GSA, GSV, RMC, VTG, TXT USB Power Mode: Bus Powered |
| UART Input | 9600 Baud, 8 bits, no parity bit, 1 stop bit, Autobauding disabled Automatically accepts following protocols without need of explicit configuration: UBX, NMEA, RTCM The GNSS receiver supports interleaved UBX and NMEA messages. |
| USB Input | Automatically accepts following protocols without need of explicit configuration: UBX, NMEA The GPS receiver supports interleaved UBX and NMEA messages. USB Power Mode: Bus Powered |
| DDC | Fully compatible with the I ² C industry standard, available for communication with an external host CPU or u-blox cellular modules, operated in slave mode only. Default messages activated. NMEA and UBX are enabled as input messages, only NMEA as output messages. Maximum bit rate 400 kb/s. |
| SPI | Allow communication to a host CPU, operated in slave mode only. Default messages activated. SPI is not available in the default configuration. |
| TIMEPULSE | disabled |

Table 13: Default messages



Refer to the *u-blox 8 / u-blox M8 Receiver Description Including Protocol Specification [2], [3]* for information about further settings.

9 Labeling and ordering information

9.1 Product labeling

The labeling of u-blox M8 GNSS modules includes important product information. The location of the NEO-M8P product type number is shown in Figure 7.

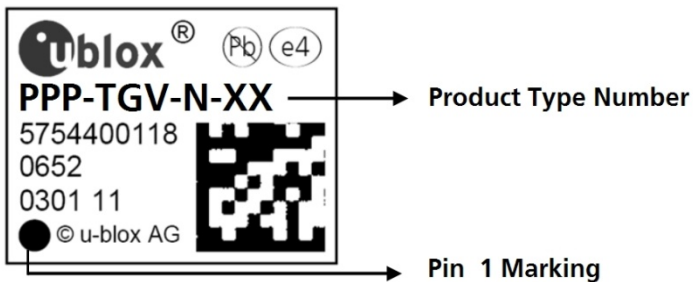

Figure 7: Location of product type number on the u-blox NEO-M8P module label

9.2 Explanation of codes

Three different product code formats are used. The **Product Name** is used in documentation such as this data sheet and identifies all u-blox M8 products, independent of packaging and quality grade. The **Ordering Code** includes options and quality, while the **Type Number** includes the hardware and firmware versions. Table 14 shows the structure of these three different formats.

| Format | Structure |
|---------------|--------------|
| Product Name | PPP-TGV |
| Ordering Code | PPP-TGV-N |
| Type Number | PPP-TGV-N-XX |

Table 14: Product Code Formats

The parts of the product code are explained in Table 16.

| Code | Meaning | Example |
|------|------------------------|---|
| PPP | Product Family | NEO |
| TG | Platform | M8 = u-blox M8 |
| V | Variant | Function set (A-Z), T = Timing, R = DR, etc. |
| N | Option / Quality Grade | Describes standardized functional element or quality grade 0 = Default variant, A = Automotive |
| XX | Product Detail | Describes product details or options such as hard- and software revision, cable length, etc. |

Table 15: part identification code

9.3 Ordering codes

| Ordering No. | Product |
|--------------|---|
| NEO-M8P-0 | u-blox M8 GNSS RTK module with rover functionality, 12.2x16 mm, 250 pcs/reel |
| NEO-M8P-2 | u-blox M8 GNSS RTK module with rover and base station functionality, 12.2x16 mm, 250 pcs/reel |

Table 16: Product ordering codes for NEO-M8P professional grade modules



Product changes affecting form, fit or function are documented by u-blox. For a list of Product Change Notifications (PCNs) see our website.

Appendix

Glossary

| Abbreviation | Definition |
|--------------|--|
| AEC | Automotive Electronics Council |
| CDMA | Code Division Multiple Access |
| DDC | Display Data Channel |
| EMC | Electromagnetic Compatibility |
| EMI | Electromagnetic Interference |
| EOS | Electrical Overstress |
| EPA | Electrostatic Protective Area |
| ESD | Electrostatic Discharge |
| GLONASS | Russian satellite navigation system |
| GND | Ground |
| GNSS | Global Navigation Satellite System |
| GPS | Global Positioning System |
| GSM | Global System for Mobile Communications |
| I2C | Inter-Integrated Circuit interconnect |
| IEC | International Electrotechnical Commission |
| ISO | International Standards Organization for Standardization |
| NED | North East Down local Cartesian coordinates |
| NMEA | National Marine Electronics Association |
| PCB | Printed Circuit Board |
| PCN | Product Change Notification |
| PPP | Precise Point Positioning |
| QZSS | Quasi-Zenith Satellite System |
| RF | Radio Frequency |
| RTCM | Radio Technical Commission for Maritime Services |
| RTK | Real Time Kinematic |
| SBAS | Spaced Based Augmentation System |
| SPI | Serial Peripheral Interface |
| TCXO | Temperature Compensated Crystal Oscillator |
| UART | Universal Asynchronous Receiver/Transmitter |
| UAV | Unmanned Aerial Vehicle |
| USB | Universal Serial Bus |

Table 17: Explanation of abbreviations used

Related documents

- [1] NEO-M8P Hardware Integration Manual, Docu. No. UBX-15021148
- [2] u-blox 8 / u-blox M8 Receiver Description Including Protocol Specification (Public version), Docu. No. UBX-13003221
- [3] Protocol Specification Addendum for HPG1.00, Docu. No. UBX-16004304
- [4] u-blox Package Information Guide, Docu. No. UBX-14001652
- [5] Power Management Application Note, Docu. No. UBX-13005162
- [6] MultiGNSS-Assistance UserGuide, Docu. No. UBX-13004360
- [7] RTCM 10403.2, 'Differential GNSS Services - Version 3, (February 1, 2013)



For regular updates to u-blox documentation and to receive product change notifications, register on our homepage (<http://www.u-blox.com>).

Revision history

| Revision | Date | Name | Status / Comments |
|----------|-------------|-----------|-------------------------------|
| R01 | 15-Oct-2015 | mstr | Objective Specification |
| R02 | 15-Feb-2016 | byou/mstr | Updated to reflect ES1 status |

Contact

For complete contact information visit us at www.u-blox.com

u-blox Offices

North, Central and South America

u-blox America, Inc.

Phone: +1 703 483 3180
E-mail: info_us@u-blox.com

Regional Office West Coast:

Phone: +1 408 573 3640
E-mail: info_us@u-blox.com

Technical Support:

Phone: +1 703 483 3185
E-mail: support@u-blox.com

Headquarters Europe, Middle East, Africa

u-blox AG

Phone: +41 44 722 74 44
E-mail: info@u-blox.com
Support: support@u-blox.com

Asia, Australia, Pacific

u-blox Singapore Pte. Ltd.

Phone: +65 6734 3811
E-mail: info_ap@u-blox.com
Support: support_ap@u-blox.com

Regional Office Australia:

Phone: +61 2 8448 2016
E-mail: info_au@u-blox.com
Support: support_au@u-blox.com

Regional Office China (Beijing):

Phone: +86 10 68 133 545
E-mail: info_cn@u-blox.com
Support: support_cn@u-blox.com

Regional Office China (Chongqing):

Phone: +86 23 6815 1588
E-mail: info_cn@u-blox.com
Support: support_cn@u-blox.com

Regional Office China (Shanghai):

Phone: +86 21 6090 4832
E-mail: info_cn@u-blox.com
Support: support_cn@u-blox.com

Regional Office China (Shenzhen):

Phone: +86 755 8627 1083
E-mail: info_cn@u-blox.com
Support: support_cn@u-blox.com

Regional Office India:

Phone: +91 80 4050 9200
E-mail: info_in@u-blox.com
Support: support_in@u-blox.com

Regional Office Japan (Osaka):

Phone: +81 6 6941 3660
E-mail: info_jp@u-blox.com
Support: support_jp@u-blox.com

Regional Office Japan (Tokyo):

Phone: +81 3 5775 3850
E-mail: info_jp@u-blox.com
Support: support_jp@u-blox.com

Regional Office Korea:

Phone: +82 2 542 0861
E-mail: info_kr@u-blox.com
Support: support_kr@u-blox.com

Regional Office Taiwan:

Phone: +886 2 2657 1090
E-mail: info_tw@u-blox.com
Support: support_tw@u-blox.com