

STM32 microcontroller system memory boot mode

Introduction

The bootloader is stored in the internal boot ROM (system memory) of STM32 devices, and is programmed by ST during production. Its main task is to download the application program to the internal Flash memory through one of the available serial peripherals (such as USART, CAN, USB, I²C, SPI). A communication protocol is defined for each serial interface, with a compatible command set and sequence.

This document applies to the products listed in [Table 1](#), referred to as STM32 throughout the document. It describes the supported peripherals and hardware requirements to consider when using the bootloader of STM32 devices.

Table 1. Applicable products

Type	Part number or product series
Microcontrollers	STM32F0 Series: STM32F03xxx, STM32F04xxx, STM32F05xxx, STM32F07xxx, STM32F09xxx
	STM32F1 Series
	STM32F2 Series
	STM32F3 Series: STM32F301xx, STM32F302xx, STM32F303xx, STM32F318xx, STM32F328xx, STM32F334xx, STM32F358xx, STM32F373xx, STM32F378xx, STM32F398xx
	STM32F4 Series: STM32F401xx, STM32F405xx, STM32F407xx, STM32F410xx, STM32F411xx, STM32F412xx, STM32F413xx, STM32F415xx, STM32F417xx, STM32F423xx, STM32F427xx, STM32F429xx, STM32F437xx, STM32F439xx, STM32F446xx, STM32F469xx, STM32F479xx
	STM32F7 Series: STM32F722xx, STM32F723xx, STM32F732xx, STM32F733xx, STM32F745xx, STM32F746xx, STM32F756xx, STM32F765xx, STM32F767xx, STM32F769xx, STM32F777xx, STM32F779xx
	STM32G0 Series: STM32G030xx, STM32G031xx, STM32G041xx, STM32G07xxx, STM32G08xxx, STM32G0B0xx, STM32G0B1xx, STM32G0C1xx
	STM32G4 Series: STM32G431xx, STM32G441xx, STM32G47xxx, STM32G48xxx
	STM32H7 Series: STM32H72xxx, STM32H73xxx, STM32H74xxx, STM32H75xxx, STM32H7A3xx, STM32H7B3xx
	STM32L0 Series
	STM32L1 Series: STM32L100xx, STM32L151xx, STM32L152xx, STM32L162xx
	STM32L4 Series: STM32L431xx, STM32L432xx, STM32L433xx, STM32L442xx, STM32L443xx, STM32L451xx, STM32L452xx, STM32L462xx, STM32L471xx, STM32L475xx, STM32L476xx, STM32L486xx, STM32L496xx, STM32L4A6xx, STM32L4R5xx, STM32L4R7xx, STM32L4R9xx, STM32L4S5xx, STM32L4S7xx, STM32L4S9xx, STM32L412xx, STM32L422xx, STM32L4P5xx, STM32L4Q5xx, STM32L431xx, STM32L432xx, STM32L433xx, STM32L442xx, STM32L443xx, STM32L451xx, STM32L452xx, STM32L462xx, STM32L471xx, STM32L475xx, STM32L476xx, STM32L486xx, STM32L496xx, STM32L4A6xx, STM32L4R5xx, STM32L4R7xx, STM32L4R9xx, STM32L4S5xx, STM32L4S7xx, STM32L4S9xx, STM32L412xx, STM32L422xx, STM32L4P5xx, STM32L4Q5xx
	STM32L5 Series: STM32L552xx, STM32L562xx
	STM32WB Series: STM32WB30xx, STM32WB35xx, STM32WB50xx, STM32WB55xx
	STM32WL Series: STM32WLE5xx STM32WL55xx

Contents

1	General information	18
2	Related documents	18
3	Glossary	19
4	General bootloader description	24
4.1	Bootloader activation	24
4.2	Bootloader identification	27
4.3	Hardware connection requirements	35
4.4	Bootloader memory management	37
4.5	Bootloader UART baudrate detection	38
4.6	Programming constraints	39
4.7	ExitSecureMemory feature	40
5	STM32F03xx4/6 devices bootloader	43
5.1	Bootloader configuration	43
5.2	Bootloader selection	44
5.3	Bootloader version	44
6	STM32F030xC devices bootloader	45
6.1	Bootloader configuration	45
6.2	Bootloader selection	46
6.3	Bootloader version	46
7	STM32F05xxx and STM32F030x8 devices bootloader	47
7.1	Bootloader configuration	47
7.2	Bootloader selection	48
7.3	Bootloader version	48
8	STM32F04xxx devices bootloader	49
8.1	Bootloader configuration	49
8.2	Bootloader selection	51

8.3	Bootloader version	52
9	STM32F070x6 devices bootloader	53
9.1	Bootloader configuration	53
9.2	Bootloader selection	55
9.3	Bootloader version	56
10	STM32F070xB devices bootloader	57
10.1	Bootloader configuration	57
10.2	Bootloader selection	59
10.3	Bootloader version	60
11	STM32F071xx/072xx devices bootloader	61
11.1	Bootloader configuration	61
11.2	Bootloader selection	63
11.3	Bootloader version	63
12	STM32F09xxx devices bootloader	64
12.1	Bootloader configuration	64
12.2	Bootloader selection	65
12.3	Bootloader version	65
13	STM32F10xxx devices bootloader	66
13.1	Bootloader configuration	66
13.2	Bootloader selection	67
13.3	Bootloader version	67
14	STM32F105xx/107xx devices bootloader	69
14.1	Bootloader configuration	69
14.2	Bootloader selection	71
14.3	Bootloader version	72
14.3.1	How to identify STM32F105xx/107xx bootloader versions	72
14.3.2	Bootloader unavailability on STM32F105xx/STM32F107xx devices with date code lower than 937	73
14.3.3	USART bootloader Get-Version command returns 0x20 instead of 0x22	74

	14.3.4	PA9 excessive power consumption when USB cable is plugged in bootloader V2.0	74
15		STM32F10xxx XL-density devices bootloader	75
	15.1	Bootloader configuration	75
	15.2	Bootloader selection	76
	15.3	Bootloader version	76
16		STM32F2xxxx devices bootloader	78
	16.1	Bootloader V2.x	78
	16.1.1	Bootloader configuration	78
	16.1.2	Bootloader selection	79
	16.1.3	Bootloader version	80
	16.2	Bootloader V3.x	81
	16.2.1	Bootloader configuration	81
	16.2.2	Bootloader selection	83
	16.2.3	Bootloader version	84
17		STM32F301xx/302x4(6/8) devices bootloader	85
	17.1	Bootloader configuration	85
	17.2	Bootloader selection	87
	17.3	Bootloader version	87
18		STM32F302xB(C)/303xB(C) devices bootloader	88
	18.1	Bootloader configuration	88
	18.2	Bootloader selection	90
	18.3	Bootloader version	90
19		STM32F302xD(E)/303xD(E) devices bootloader	91
	19.1	Bootloader configuration	91
	19.2	Bootloader selection	93
	19.3	Bootloader version	94
20		STM32F303x4(6/8)/334xx/328xx devices bootloader	95
	20.1	Bootloader configuration	95
	20.2	Bootloader selection	96

20.3	Bootloader version	96
21	STM32F318xx devices bootloader	97
21.1	Bootloader configuration	97
21.2	Bootloader selection	98
21.3	Bootloader version	99
22	STM32F358xx devices bootloader	100
22.1	Bootloader configuration	100
22.2	Bootloader selection	101
22.3	Bootloader version	101
23	STM32F373xx devices bootloader	102
23.1	Bootloader configuration	102
23.2	Bootloader selection	104
23.3	Bootloader version	104
24	STM32F378xx devices bootloader	105
24.1	Bootloader configuration	105
24.2	Bootloader selection	106
24.3	Bootloader version	106
25	STM32F398xx devices bootloader	107
25.1	Bootloader configuration	107
25.2	Bootloader selection	108
25.3	Bootloader version	108
26	STM32F40xxx/41xxx devices bootloader	109
26.1	Bootloader V3.x	109
26.1.1	Bootloader configuration	109
26.1.2	Bootloader selection	111
26.1.3	Bootloader version	112
26.2	Bootloader V9.x	113
26.2.1	Bootloader configuration	113
26.2.2	Bootloader selection	117
26.2.3	Bootloader version	118

27	STM32F401xB(C) devices bootloader	119
	27.1 Bootloader configuration	119
	27.2 Bootloader selection	123
	27.3 Bootloader version	124
28	STM32F401xD(E) devices bootloader	125
	28.1 Bootloader configuration	125
	28.2 Bootloader selection	128
	28.3 Bootloader version	129
29	STM32F410xx devices bootloader	130
	29.1 Bootloader configuration	130
	29.2 Bootloader selection	133
	29.3 Bootloader version	134
30	STM32F411xx devices bootloader	135
	30.1 Bootloader configuration	135
	30.2 Bootloader selection	139
	30.3 Bootloader version	140
31	STM32F412xx devices bootloader	141
	31.1 Bootloader configuration	141
	31.2 Bootloader selection	145
	31.3 Bootloader version	146
32	STM32F413xx/423xx devices bootloader	147
	32.1 Bootloader configuration	147
	32.2 Bootloader selection	152
	32.3 Bootloader version	153
33	STM32F42xxx/43xxx devices bootloader	154
	33.1 Bootloader V7.x	154
	33.1.1 Bootloader configuration	154
	33.1.2 Bootloader selection	156
	33.1.3 Bootloader version	158

33.2	Bootloader V9.x	159
33.2.1	Bootloader configuration	159
33.2.2	Bootloader selection	163
33.2.3	Bootloader version	165
34	STM32F446xx devices bootloader	166
34.1	Bootloader configuration	166
34.2	Bootloader selection	170
34.3	Bootloader version	171
35	STM32F469xx/479xx devices bootloader	172
35.1	Bootloader configuration	172
35.2	Bootloader selection	176
35.3	Bootloader version	178
36	STM32F72xxx/73xxx devices bootloader	179
36.1	Bootloader configuration	179
36.2	Bootloader selection	183
36.3	Bootloader version	184
37	STM32F74xxx/75xxx devices bootloader	185
37.1	Bootloader V7.x	186
37.1.1	Bootloader configuration	186
37.1.2	Bootloader selection	189
37.1.3	Bootloader version	190
37.2	Bootloader V9.x	191
37.2.1	Bootloader configuration	191
37.2.2	Bootloader selection	195
37.2.3	Bootloader version	196
38	STM32F76xxx/77xxx devices bootloader	197
38.1	Bootloader configuration	197
38.2	Bootloader selection	201
38.3	Bootloader version	203
39	STM32G03xxx/ STM32G04xxx devices bootloader	204

39.1	Bootloader configuration	204
39.2	Bootloader selection	205
39.3	Bootloader version	206
40	STM32G07xxx/08xxx device bootloader	207
40.1	Bootloader configuration	207
40.2	Bootloader selection	209
40.3	Bootloader version	209
41	STM32G0B0xx device bootloader	210
41.1	Bootloader configuration	210
41.2	Bootloader selection	213
41.3	Bootloader version	214
42	STM32G0B1xx/0C1xx device bootloader	215
42.1	Bootloader configuration	215
42.2	Bootloader selection	218
42.3	Bootloader version	219
43	STM32G431xx/441xx devices bootloader	220
43.1	Bootloader configuration	220
43.2	Bootloader selection	223
43.3	Bootloader version	224
44	STM32G47xxx/48xxx devices bootloader	225
44.1	Bootloader configuration	225
44.2	Bootloader selection	228
44.3	Bootloader version	229
45	STM32H72xxx/73xxx devices bootloader	230
45.1	Bootloader configuration	230
45.2	Bootloader selection	233
45.3	Bootloader version	234
46	STM32H74xxx/75xxx devices bootloader	235

46.1	Bootloader configuration	235
46.2	Bootloader selection	239
46.3	Bootloader version	240
47	STM32H7A3xx/B3xx devices bootloader	241
47.1	Bootloader configuration	241
47.2	Bootloader selection	245
47.3	Bootloader version	246
48	STM32L01xxx/02xxx devices bootloader	247
48.1	Bootloader configuration	247
48.2	Bootloader selection	249
48.3	Bootloader version	250
49	STM32L031xx/041xx devices bootloader	251
49.1	Bootloader configuration	251
49.2	Bootloader selection	253
49.3	Bootloader version	253
50	STM32L05xxx/06xxx devices bootloader	254
50.1	Bootloader configuration	254
50.2	Bootloader selection	256
50.3	Bootloader version	256
51	STM32L07xxx/08xxx devices bootloader	257
51.1	Bootloader V4.x	257
51.1.1	Bootloader configuration	257
51.1.2	Bootloader selection	259
51.1.3	Bootloader version	260
51.2	Bootloader V11.x	261
51.2.1	Bootloader configuration	261
51.2.2	Bootloader selection	263
51.2.3	Bootloader version	265
52	STM32L1xxx6(8/B)A devices bootloader	266
52.1	Bootloader configuration	266

52.2	Bootloader selection	267
52.3	Bootloader version	267
53	STM32L1xxx6(8/B) devices bootloader	268
53.1	Bootloader configuration	268
53.2	Bootloader selection	269
53.3	Bootloader version	269
54	STM32L1xxxC devices bootloader	270
54.1	Bootloader configuration	270
54.2	Bootloader selection	272
54.3	Bootloader version	272
55	STM32L1xxxD devices bootloader	273
55.1	Bootloader configuration	273
55.2	Bootloader selection	275
55.3	Bootloader version	276
56	STM32L1xxxE devices bootloader	277
56.1	Bootloader configuration	277
56.2	Bootloader selection	279
56.3	Bootloader version	280
57	STM32L412xx/422xx devices bootloader	281
57.1	Bootloader configuration	281
57.2	Bootloader selection	284
57.3	Bootloader version	286
58	STM32L43xxx/44xxx devices bootloader	287
58.1	Bootloader configuration	287
58.2	Bootloader selection	291
58.3	Bootloader version	293
59	STM32L45xxx/46xxx devices bootloader	295
59.1	Bootloader configuration	295

59.2	Bootloader selection	299
59.3	Bootloader version	301
60	STM32L47xxx/48xxx devices bootloader	302
60.1	Bootloader V10.x	302
60.1.1	Bootloader configuration	302
60.1.2	Bootloader selection	305
60.1.3	Bootloader version	307
60.2	Bootloader V9.x	308
60.2.1	Bootloader configuration	308
60.2.2	Bootloader selection	311
60.2.3	Bootloader version	313
61	STM32L496xx/4A6xx devices bootloader	314
61.1	Bootloader configuration	314
61.2	Bootloader selection	318
61.3	Bootloader version	320
62	STM32L4P5xx/4Q5xx devices bootloader	321
62.1	Bootloader configuration	321
62.2	Bootloader selection	325
62.3	Bootloader version	327
63	STM32L4Rxxx/4Sxxx devices bootloader	328
63.1	Bootloader configuration	328
63.2	Bootloader selection	332
63.3	Bootloader version	334
64	STM32L552xx/STM32L562xx devices bootloader	335
64.1	Bootloader configuration	335
64.2	Bootloader selection	339
64.3	Bootloader version	340
65	STM32WB30xx/35xx/50xx/55xx devices bootloader	341
65.1	Bootloader configuration	341
65.2	Bootloader selection	344

65.3	Bootloader version	345
66	STM32WLE5xx/55xx devices bootloader	346
66.1	Bootloader configuration	346
66.2	Bootloader selection	348
66.3	Bootloader version	348
67	Device-dependent bootloader parameters	349
68	Bootloader timings	354
68.1	Bootloader startup timing	354
68.2	USART connection timing	357
68.3	USB connection timing	359
68.4	I2C connection timing	362
68.5	SPI connection timing	365
Appendix A Example of function to use the “ExitSecureMemory” function .		366
69	Revision history	369

List of tables

Table 1.	Applicable products	1
Table 2.	Bootloader activation patterns	24
Table 3.	Embedded bootloaders	28
Table 4.	STM32 F2, F4 and F7 voltage range configuration using bootloader	38
Table 5.	Supported memory area by Write, Read, Erase and Go commands	38
Table 6.	Jitter software calculation on bootloader USART detection	39
Table 7.	Flash memory alignment constraints on STM32 products	39
Table 8.	ExitSecureMemory entry address	41
Table 9.	STM32F03xx4/6 configuration in system memory boot mode	43
Table 10.	STM32F03xx4/6 bootloader versions	44
Table 11.	STM32F030xC configuration in system memory boot mode	45
Table 12.	STM32F030xC bootloader versions	46
Table 13.	STM32F05xxx and STM32F030x8 devices configuration in system memory boot mode	47
Table 14.	STM32F05xxx and STM32F030x8 devices bootloader versions	48
Table 15.	STM32F04xxx configuration in system memory boot mode	49
Table 16.	STM32F04xxx bootloader versions	52
Table 17.	STM32F070x6 configuration in system memory boot mode	53
Table 18.	STM32F070x6 bootloader versions	56
Table 19.	STM32F070xB configuration in system memory boot mode	57
Table 20.	STM32F070xB bootloader versions	60
Table 21.	STM32F071xx/072xx configuration in system memory boot mode	61
Table 22.	STM32F071xx/072xx bootloader versions	63
Table 23.	STM32F09xxx configuration in system memory boot mode	64
Table 24.	STM32F09xxx bootloader versions	65
Table 25.	STM32F10xxx configuration in system memory boot mode	66
Table 26.	STM32F10xxx bootloader versions	67
Table 27.	STM32F105xx/107xx configuration in system memory boot mode	69
Table 28.	STM32F105xx/107xx bootloader versions	72
Table 29.	STM32F10xxx XL-density configuration in system memory boot mode	75
Table 30.	STM32F10xxx XL-density bootloader versions	76
Table 31.	STM32F2xxxx configuration in system memory boot mode	78
Table 32.	STM32F2xxxx bootloader V2.x versions	80
Table 33.	STM32F2xxxx configuration in system memory boot mode	81
Table 34.	STM32F2xxxx bootloader V3.x versions	84
Table 35.	STM32F301xx/302x4(6/8) configuration in system memory boot mode	85
Table 36.	STM32F301xx/302x4(6/8) bootloader versions	87
Table 37.	STM32F302xB(C)/303xB(C) configuration in system memory boot mode	88
Table 38.	STM32F302xB(C)/303xB(C) bootloader versions	90
Table 39.	STM32F302xD(E)/303xD(E) configuration in system memory boot mode	91
Table 40.	STM32F302xD(E)/303xD(E) bootloader versions	94
Table 41.	STM32F303x4(6/8)/334xx/328xx configuration in system memory boot mode	95
Table 42.	STM32F303x4(6/8)/334xx/328xx bootloader versions	96
Table 43.	STM32F318xx configuration in system memory boot mode	97
Table 44.	STM32F318xx bootloader versions	99
Table 45.	STM32F358xx configuration in system memory boot mode	100
Table 46.	STM32F358xx bootloader versions	101
Table 47.	STM32F373xx configuration in system memory boot mode	102
Table 48.	STM32F373xx bootloader versions	104

Table 49.	STM32F378xx configuration in system memory boot mode.	105
Table 50.	STM32F378xx bootloader versions	106
Table 51.	STM32F398xx configuration in system memory boot mode.	107
Table 52.	STM32F398xx bootloader versions	108
Table 53.	STM32F40xxx/41xxx configuration in system memory boot mode.	109
Table 54.	STM32F40xxx/41xxx bootloader V3.x versions	112
Table 55.	STM32F40xxx/41xxx configuration in system memory boot mode.	113
Table 56.	STM32F40xxx/41xxx bootloader V9.x versions	118
Table 57.	STM32F401xB(C) configuration in system memory boot mode.	119
Table 58.	STM32F401xB(C) bootloader versions	124
Table 59.	STM32F401xD(E) configuration in system memory boot mode.	125
Table 60.	STM32F401xD(E) bootloader versions	129
Table 61.	STM32F410xx configuration in system memory boot mode.	130
Table 62.	STM32F410xx bootloader V11.x versions	134
Table 63.	STM32F411xx configuration in system memory boot mode.	135
Table 64.	STM32F411xx bootloader versions	140
Table 65.	STM32F412xx configuration in system memory boot mode.	141
Table 66.	STM32F412xx bootloader V9.x versions	146
Table 67.	STM32F413xx/423xx configuration in system memory boot mode	147
Table 68.	STM32F413xx/423xx bootloader V9.x versions	153
Table 69.	STM32F42xxx/43xxx configuration in system memory boot mode.	154
Table 70.	STM32F42xxx/43xxx bootloader V7.x versions	158
Table 71.	STM32F42xxx/43xxx configuration in system memory boot mode.	159
Table 72.	STM32F42xxx/43xxx bootloader V9.x versions	165
Table 73.	STM32F446xx configuration in system memory boot mode.	166
Table 74.	STM32F446xx bootloader V9.x versions	171
Table 75.	STM32F469xx/479xx configuration in system memory boot mode	172
Table 76.	STM32F469xx/479xx bootloader V9.x versions	178
Table 77.	STM32F72xxx/73xxx configuration in system memory boot mode.	179
Table 78.	STM32F72xxx/73xxx bootloader V9.x versions	184
Table 79.	STM32F74xxx/75xxx configuration in system memory boot mode.	186
Table 80.	STM32F74xxx/75xxx bootloader V7.x versions	190
Table 81.	STM32F74xxx/75xxx configuration in system memory boot mode.	191
Table 82.	STM32F74xxx/75xxx bootloader V9.x versions	196
Table 83.	STM32F76xxx/77xxx configuration in system memory boot mode.	197
Table 84.	STM32F76xxx/77xxx bootloader V9.x versions	203
Table 85.	STM32G03xxx/G04xxx configuration in system memory boot mode.	204
Table 86.	STM32G03xxx/04xxx bootloader versions	206
Table 87.	STM32G07xxx/8xxx configuration in system memory boot mode	207
Table 88.	STM32G07xx/08xxx bootloader versions	209
Table 89.	STM32G0B0xx configuration in system memory boot mode	210
Table 90.	STM32G0B0xx bootloader versions	214
Table 91.	STM32G0B1xx/0C1xx configuration in system memory boot mode.	215
Table 92.	STM32G0B1xx/0C1xx bootloader versions	219
Table 93.	STM32G431xx/441xx configuration in system memory boot mode	220
Table 94.	STM32G431xx/441xx bootloader version.	224
Table 95.	STM32G47xxx/48xxx configuration in system memory boot mode	225
Table 96.	STM32G47xxx/48xxx bootloader version.	229
Table 97.	STM32H72xxx/73xxx configuration in system memory boot mode	230
Table 98.	STM32H72xxx/73xxx bootloader version	234
Table 99.	STM32H74xxx/75xxx configuration in system memory boot mode	235
Table 100.	STM32H74xxx/75xxx bootloader version	240

Table 101.	STM32H7A3xx/7B3xx configuration in system memory boot mode	241
Table 102.	STM32H7A3xx/7B3xx bootloader version	246
Table 103.	STM32L01xxx/02xxx configuration in system memory boot mode	247
Table 104.	STM32L01xxx/02xxx bootloader versions	250
Table 105.	STM32L031xx/041xx configuration in system memory boot mode	251
Table 106.	STM32L031xx/041xx bootloader versions	253
Table 107.	STM32L05xxx/06xxx configuration in system memory boot mode	254
Table 108.	STM32L05xxx/06xxx bootloader versions	256
Table 109.	STM32L07xxx/08xxx configuration in system memory boot mode	257
Table 110.	STM32L07xxx/08xxx bootloader versions	260
Table 111.	STM32L07xxx/08xxx configuration in system memory boot mode	261
Table 112.	STM32L07xxx/08xxx bootloader V11.x versions	265
Table 113.	STM32L1xxx6(8/B)A configuration in system memory boot mode	266
Table 114.	STM32L1xxx6(8/B)A bootloader versions	267
Table 115.	STM32L1xxx6(8/B) configuration in system memory boot mode	268
Table 116.	STM32L1xxx6(8/B) bootloader versions	269
Table 117.	STM32L1xxxC configuration in system memory boot mode	270
Table 118.	STM32L1xxxC bootloader versions	272
Table 119.	STM32L1xxxD configuration in system memory boot mode	273
Table 120.	STM32L1xxxD bootloader versions	276
Table 121.	STM32L1xxxE configuration in system memory boot mode	277
Table 122.	STM32L1xxxE bootloader versions	280
Table 123.	STM32L412xx/422xx configuration in system memory boot mode	281
Table 124.	STM32L412xx/422xx bootloader versions	286
Table 125.	STM32L43xxx/44xxx configuration in system memory boot mode	287
Table 126.	STM32L43xxx/44xxx bootloader versions	293
Table 127.	STM32L45xxx/46xxx configuration in system memory boot mode	295
Table 128.	STM32L45xxx/46xxx bootloader versions	301
Table 129.	STM32L47xxx/48xxx configuration in system memory boot mode	302
Table 130.	STM32L47xxx/48xxx bootloader V10.x versions	307
Table 131.	STM32L47xxx/48xxx configuration in system memory boot mode	308
Table 132.	STM32L47xxx/48xxx bootloader V9.x versions	313
Table 133.	STM32L496xx/4A6xx configuration in system memory boot mode	314
Table 134.	STM32L496xx/4A6xx bootloader version	320
Table 135.	STM32L4P5xx/4Q5xx configuration in system memory boot mode	321
Table 136.	STM32L4P5xx/4Q5xx bootloader versions	327
Table 137.	STM32L4Rxxx/4Sxxx configuration in system memory boot mode	328
Table 138.	STM32L4Rxxx/4Sxx bootloader versions	334
Table 139.	STM32L552xx/562xx configuration in system memory boot mode	335
Table 140.	STM32L552xx/562xx bootloader versions	340
Table 141.	STM32WB30xx/35xx/50xx/55xx configuration in system memory boot mode	341
Table 142.	STM32WB30xx/35xx/50xx/55xx bootloader versions	345
Table 143.	STM32WLE5xx/55xx configuration in system memory boot mode	346
Table 144.	STM32WLE5xx/55xx bootloader versions	348
Table 145.	Bootloader device-dependent parameters	349
Table 146.	Bootloader startup timings (ms) for STM32 devices	354
Table 147.	USART bootloader minimum timings (ms) for STM32 devices	357
Table 148.	USB bootloader minimum timings (ms) for STM32 devices	360
Table 149.	I2C bootloader minimum timings (ms) for STM32 devices	362
Table 150.	SPI bootloader minimum timings (ms) for STM32 devices	365
Table 151.	Document revision history	369

List of figures

Figure 1.	USART connection	35
Figure 2.	USB connection	35
Figure 3.	I2C connection	36
Figure 4.	SPI connection	36
Figure 5.	CAN connection	36
Figure 6.	ExitSecureMemory function usage	41
Figure 7.	Access to securable memory area from the bootloader	42
Figure 8.	Bootloader selection for STM32F03xx4/6 devices	44
Figure 9.	Bootloader selection for STM32F030xC	46
Figure 10.	Bootloader selection for STM32F05xxx and STM32F030x8 devices	48
Figure 11.	Bootloader selection for STM32F04xxx	51
Figure 12.	Bootloader selection for STM32F070x6	55
Figure 13.	Bootloader selection for STM32F070xB	59
Figure 14.	Bootloader selection for STM32F071xx/072xx	63
Figure 15.	Bootloader selection for STM32F09xxx	65
Figure 16.	Bootloader selection for STM32F10xxx	67
Figure 17.	Bootloader selection for STM32F105xx/107xx devices	71
Figure 18.	Bootloader selection for STM32F10xxx XL-density devices	76
Figure 19.	Bootloader V2.x selection for STM32F2xxxx devices	79
Figure 20.	Bootloader V3.x selection for STM32F2xxxx devices	83
Figure 21.	Bootloader selection for STM32F301xx/302x4(6/8)	87
Figure 22.	Bootloader selection for STM32F302xB(C)/303xB(C) devices	90
Figure 23.	Bootloader selection for STM32F302xD(E)/303xD(E)	93
Figure 24.	Bootloader selection for STM32F303x4(6/8)/334xx/328xx	96
Figure 25.	Bootloader selection for STM32F318xx	98
Figure 26.	Bootloader selection for STM32F358xx devices	101
Figure 27.	Bootloader selection for STM32F373xx devices	104
Figure 28.	Bootloader selection for STM32F378xx devices	106
Figure 29.	Bootloader selection for STM32F398xx	108
Figure 30.	Bootloader V3.x selection for STM32F40xxx/41xxx devices	111
Figure 31.	Bootloader V9.x selection for STM32F40xxx/41xxx	117
Figure 32.	Bootloader selection for STM32F401xB(C)	123
Figure 33.	Bootloader selection for STM32F401xD(E)	128
Figure 34.	Bootloader V11.x selection for STM32F410xx	133
Figure 35.	Bootloader selection for STM32F411xx	139
Figure 36.	Bootloader V9.x selection for STM32F412xx	145
Figure 37.	Bootloader V9.x selection for STM32F413xx/423xx	152
Figure 38.	Dual bank boot implementation for STM32F42xxx/43xxx Bootloader V7.x	156
Figure 39.	Bootloader V7.x selection for STM32F42xxx/43xxx	157
Figure 40.	Dual bank boot implementation for STM32F42xxx/43xxx bootloader V9.x	163
Figure 41.	Bootloader V9.x selection for STM32F42xxx/43xxx	164
Figure 42.	Bootloader V9.x selection for STM32F446xx	170
Figure 43.	Dual bank boot implementation for STM32F469xx/479xx Bootloader V9.x	176
Figure 44.	Bootloader V9.x selection for STM32F469xx/479xx	177
Figure 45.	Bootloader V9.x selection for STM32F72xxx/73xxx	183
Figure 46.	Bootloader V7.x selection for STM32F74xxx/75xxx	189
Figure 47.	Bootloader V9.x selection for STM32F74xxx/75xxx	195
Figure 48.	Dual bank boot implementation for STM32F76xxx/77xxx Bootloader V9.x	201

Figure 49.	Bootloader V9.x selection for STM32F76xxx/77xxx	202
Figure 50.	Bootloader V5.x selection for STM32G03xxx/G04xxx	205
Figure 51.	Bootloader V11.0 selection for STM32G07xxx/G08xxx	209
Figure 52.	Bootloader selection for STM32G0B0xx	213
Figure 53.	Bootloader selection for STM32G0B1xx/0C1xx	218
Figure 54.	Bootloader selection for STM32G431xx/441xx	223
Figure 55.	Bootloader selection for STM32G47xxx/48xxx	228
Figure 56.	Dual bank boot implementation for STM32G47xxx/48xxx bootloader V13.x	229
Figure 57.	Bootloader V9.0 selection for STM32H72xxx/73xxx	233
Figure 58.	Bootloader V9.x selection for STM32H74xxx/75xxx	239
Figure 59.	Bootloader V9.x selection for STM32H7A3xx/7B3xx	245
Figure 60.	Bootloader selection for STM32L01xxx/02xxx	249
Figure 61.	Bootloader selection for STM32L031xx/041xx	253
Figure 62.	Bootloader selection for STM32L05xxx/06xxx	256
Figure 63.	Dual bank boot implementation for STM32L07xxx/08xxx bootloader V4.x	259
Figure 64.	Bootloader V4.x selection for STM32L07xxx/08xxx	260
Figure 65.	Dual bank boot implementation for STM32L07xxx/08xxx bootloader V11.x	263
Figure 66.	Bootloader V11.x selection for STM32L07xxx/08xxx	264
Figure 67.	Bootloader selection for STM32L1xxx6(8/B)A devices	267
Figure 68.	Bootloader selection for STM32L1xxx6(8/B) devices	269
Figure 69.	Bootloader selection for STM32L1xxx C devices	272
Figure 70.	Bootloader selection for STM32L1xxx D devices	275
Figure 71.	Bootloader selection for STM32L1xxx E devices	279
Figure 72.	Dual bank boot Implementation for STM32L412xx/422xx bootloader V9.x	284
Figure 73.	Bootloader V13.x selection for STM32L412xx/422xx	285
Figure 74.	Dual bank boot Implementation for STM32L3x2xx/44xxx bootloader V9.x	291
Figure 75.	Bootloader V9.x selection for STM32L43xxx/44xxx	292
Figure 76.	Dual bank boot Implementation for STM32L45xxx/46xxx bootloader V9.x	299
Figure 77.	Bootloader V9.x selection for STM32L45xxx/46xxx	300
Figure 78.	Dual bank boot implementation for STM32L47xxx/48xxx bootloader V10.x	305
Figure 79.	Bootloader V10.x selection for STM32L47xxx/48xxx	306
Figure 80.	Dual bank boot implementation for STM32L47xxx/48xxx bootloader V9.x	311
Figure 81.	Bootloader V9.x selection for STM32L47xxx/48xxx	312
Figure 82.	Dual bank boot Implementation for STM32L496xx/4A6xx bootloader V9.x	318
Figure 83.	Bootloader V9.x selection for STM32L496xx/4A6xx	319
Figure 84.	Dual bank boot implementation for STM32L4P5xx/4Q5xx bootloader V9.x	325
Figure 85.	Bootloader V9.x selection for STM32L4P5xx/4Q5xx	326
Figure 86.	Dual bank boot implementation for STM32L4Rxxx/STM32L4Sxxx bootloader V9.x	332
Figure 87.	Bootloader V9.x selection for STM32L4Rxx/4Sxx	333
Figure 88.	Bootloader V9.x selection for STM32L552xx/562xx	339
Figure 89.	Bootloader V13.0 selection for STM32WB30xx/35xx/50xx/55xx	344
Figure 90.	Bootloader V12.x selection for STM32WLE5xx/55xx	348
Figure 91.	Bootloader Startup timing description	354
Figure 92.	USART connection timing description	357
Figure 93.	USB connection timing description	360
Figure 94.	I2C connection timing description	362
Figure 95.	SPI connection timing description	365

1 General information

This document applies to Arm^{®(a)}-based devices.

2 Related documents

For each supported product (listed in [Table 1](#)) refer to the following documents available from www.st.com:

- Datasheet or databrief
- Reference manual
- Application notes
 - AN3154: *CAN protocol used in the STM32 bootloader*
 - AN3155: *USART protocol used in the STM32 bootloader*
 - AN3156: *USB DFU protocol used in the STM32 bootloader*
 - AN4221: *I2C protocol used in the STM32 bootloader*
 - AN4286: *SPI protocol used in the STM32 bootloader*
 - AN5405: *FDCAN protocol used in the STM32 bootloader*

arm

a. Arm is a registered trademark of Arm Limited (or its subsidiaries) in the US and/or elsewhere.

3 Glossary

F0 Series:

STM32F03xxx is used to refer to STM32F030x4, STM32F030x6, STM32F038x6, STM32F030xC, STM32F031x4 and STM32F031x6 devices.

STM32F04xxx is used to refer to STM32F042x4 and STM32F042x6 devices.

STM32F05xxx and STM32F030x8 devices is used to refer to STM32F051x4, STM32F051x6, STM32F051x8, STM32F058x8 and STM32F030x8 devices.

STM32F07xxx is used to refer to STM32F070x6, STM32F070xB, STM32F071xB, STM32F072x8 and STM32F072xB devices.

STM32F09xxx is used to refer to STM32F091xx and STM32F098xx devices.

F1 Series:

STM32F10xxx is used to refer to Low-density, Medium-density, High-density, Low-density value line, Medium-density value line and High-density value line devices:

Low-density devices are STM32F101xx, STM32F102xx and STM32F103xx microcontrollers where the Flash memory density ranges between 16 and 32 Kbytes.

Medium-density devices are STM32F101xx, STM32F102xx and STM32F103xx microcontrollers where the Flash memory density ranges between 64 and 128 Kbytes.

High-density devices are STM32F101xx and STM32F103xx microcontrollers where the Flash memory density ranges between 256 and 512 Kbytes.

Low-density value line devices are STM32F100xx microcontrollers where the Flash memory density ranges between 16 and 32 Kbytes.

Medium-density value line devices are STM32F100xx microcontrollers where the Flash memory density ranges between 64 and 128 Kbytes.

High-density value line devices are STM32F100xx microcontrollers where the Flash memory density ranges between 256 and 512 Kbytes.

STM32F105xx/107xx is used to refer to STM32F105xx and STM32F107xx devices.

STM32F10xxx XL-density is used to refer to STM32F101xx and STM32F103xx devices where the Flash memory density ranges between 768 Kbytes and 1 Mbyte.

F2 Series:

STM32F2xxxx is used to refer to STM32F215xx, STM32F205xx, STM32F207xx and SMT32F217xx devices.

F3 Series:

STM32F301xx/302x4(6/8) is used to refer to STM32F301x4, STM32F301x6, STM32F301x8, STM32F302x4, STM32F302x6 and STM32F302x8 devices.

STM32F302xB(C)/303xB(C) is used to refer to STM32F302xB, STM32F302xC, STM32F303xB and STM32F303xC devices.

STM32F302xD(E)/303xD(E) is used to refer to STM32F302xD, STM32F302xE, STM32F303xD and STM32F303xE devices.

STM32F303x4(6/8)/334xx/328xx is used to refer to STM32F303x4, STM32F303x6, STM32F303x8, STM32F334x4, STM32F334x6, STM32F334x8, and STM32F328x8 devices.

STM32F318xx is used to refer to STM32F318x8 devices.

STM32F358xx is used to refer to STM32F358xC devices.

STM32F373xx is used to refer to STM32F373x8, STM32F373xB and STM32F373xC devices.

STM32F378xx is used to refer to STM32F378xC devices.

STM32F398xx is used to refer to STM32F398xE devices.

F4 Series:

STM32F40xxx/41xxx is used to refer to STM32F405xx, STM32F407xx, STM32F415xx and STM32F417xx devices.

STM32F401xB(C) is used to refer to STM32F401xB and STM32F401xC devices.

STM32F401xD(E) is used to refer to STM32F401xD and STM32F401xE devices.

STM32F410xx is used to refer to STM32F410x8 and STM32F410xB devices.

STM32F411xx is used to refer to STM32F411xD and STM32F411xE devices.

STM32F412xx is used to refer to STM32F412Cx, STM32F412Rx, STM32F412Vx and STM32F412Zx devices.

STM32F413xx/423xx is used to refer to STM32F413xG, STM32F413xH and STM32F423xH devices.

STM32F42xxx/43xxx is used to refer to STM32F427xx, STM32F429xx, STM32F437xx and STM32F439xx devices.

STM32F446xx is used to refer to STM32F446xE and STM32F446xC devices.

STM32F469xx/479xx is used to refer to STM32F469xE, STM32F469xG, STM32F469xI, STM32F479xG and STM32F479xI devices.

F7 Series:

STM32F72xxx/73xxx is used to refer to STM32F722xx, STM32F723xx, STM32F732xx and STM32F733xx devices.

STM32F74xxx/75xxx is used to refer to STM32F745xx, STM32F746xx and STM32F756xx devices.

STM32F76xxx/77xxx is used to refer to STM32F765xx, STM32F767xx, STM32F769xx, STM32F777xx and STM32F779xx devices.

G0 Series:

STM32G03xxx/04xxx is used to refer to STM32G03xxx and STM32G04xxx devices.

STM32G07xxx/08xxx is used to refer to STM32G07xxx and STM32G08xxx devices.

STM32G0B1xx/C1xx is used to refer to STM32GB1xx and STM32G0C1xxx devices.

STM32G0B0xx is used to refer to STM32G0B0xx.

G4 Series:

STM32G431xx is used to refer to STM32G431xx devices.

STM32G441xx is used to refer to STM32G441xx devices.

STM32G47xxx is used to refer to STM32G471xx, STM32G473xx and STM32G474xx devices.

STM32G48xxx is used to refer to STM32G483xx and STM32G484xx devices.

H7 Series:

STM32H72xxx/73xxx is used to refer to STM32H72xxx and STM32H73xxx devices.

STM32H74xxx/75xxx is used to refer to STM32H74xxx and STM32H75xxx devices.

STM32H7A3xx/7B3xx is used to refer to STM32H7A3xx/ STM32H7B3xx devices.

L0 Series:

STM32L01xxx/02xxx is used to refer to STM32L011xx and STM32L021xx devices.

STM32L031xx/041xx is used to refer to STM32L031xx and STM32L041xx devices.

STM32L05xxx/06xxx is used to refer to STM32L051xx, STM32L052xx, STM32L053xx, STM32L062xx and STM32L063xx ultralow power devices.

STM32L07xxx/08xxx is used to refer to STM32L071xx, STM32L072xx, STM32L073xx, STM32L081xx, STM32L082xx and STM32L083xx devices

L1 Series:

STM32L1xxx6(8/B) is used to refer to STM32L1xxV6T6, STM32L1xxV6H6, STM32L1xxR6T6, STM32L1xxR6H6, STM32L1xxC6T6, STM32L1xxC6H6, STM32L1xxV8T6, STM32L1xxV8H6, STM32L1xxR8T6, STM32L1xxR8H6, STM32L1xxC8T6, STM32L1xxC8H6, STM32L1xxVBT6, STM32L1xxVBH6, STM32L1xxRBT6, STM32L1xxRBH6, STM32L1xxCBT6 and STM32L1xxCBH6 ultralow power devices.

STM32L1xxx6(8/B)A is used to refer to STM32L1xxV6T6-A, STM32L1xxV6H6-A, STM32L1xxR6T6-A, STM32L1xxR6H6-A, STM32L1xxC6T6-A, STM32L1xxC6H6-A, STM32L1xxV8T6-A, STM32L1xxV8H6-A, STM32L1xxR8T6-A, STM32L1xxR8H6-A, STM32L1xxC8T6-A, STM32L1xxC8H6-A, STM32L1xxVBT6-A, STM32L1xxVBH6-A, STM32L1xxRBT6-A, STM32L1xxRBH6-A, STM32L1xxCBT6-A and STM32L1xxCBH6-A ultralow power devices.

STM32L1xxxC is used to refer to STM32L1xxVCT6, STM32L1xxVCH6, STM32L1xxRCT6, STM32L1xxUCY6, STM32L1xxCCT6 and STM32L1xxCCU6 ultralow power devices.

STM32L1xxxD is used to refer to STM32L1xxZDT6, STM32L1xxQDH6, STM32L1xxVDT6, STM32L1xxRDY6, STM32L1xxRDT6, STM32L1xxZCT6, STM32L1xxQCH6, STM32L1xxRCY6, STM32L1xxVCT6-A and STM32L1xxRCT6-A ultralow power devices.

STM32L1xxxE is used to refer to STM32L1xxZET6, STM32L1xxQEH6, STM32L1xxVET6, STM32L1xxVEY6, and STM32L1xxRET6 ultralow power devices.

L4 Series:

STM32L412xx/422xx is used to refer to STM32L412xB, STM32L412x8, STM32L422xB devices.

STM32L43xxx/44xxx is used to refer to STM32L431xx, STM32L432xx, STM32L433xx and STM32L442xx and STM32L443xx devices.

STM32L45xxx/46xxx is used to refer to STM32L451xx, STM32L452xx and STM32L462xx devices.

STM32L47xxx/48xxx is used to refer to STM32L471xx, STM32L475xx, STM32L476xx and STM32L486xx devices.

STM32L496xx/4A6xx is used to refer to STM32L496xE, STM32L496xG and STM32L4A6xG devices.

STM32L4Rxxx/4Sxxx is used to refer to STM32L4R5xx, STM32L4R7xx, STM32L4R9xx, STM32L4S5xx, STM32L4S7xx and STM32L4S9xx devices.

STM32L4P5xx/4Q5xx is used to refer to STM32L4P5xx/STM32L4Q5xx devices.

L5 Series:

STM32L552xx is used to refer to STM32L552xx devices.

STM32L562xx is used to refer to STM32L562xx devices.

WB Series:

STM32WB30xx is used to refer to STM32WB30xx devices.

STM32WB35xx is used to refer to STM32WB35xx devices.

STM32WB50xx is used to refer to STM32WB50xx devices.

STM32WB55xx is used to refer to STM32WB55Cx, STM32WB55Rx and STM32WB55Vx devices.

WL Series:

STM32WLE5xx is used to refer to STM32WLE5JC, STM32WLE5JB and STM32WLE5J8 devices.

STM32WL55xx is used to refer to STM32WL55xx devices.

Note:

BL_USART_Loop refers to the USART bootloader execution loop.

BL_CAN_Loop refers to the CAN bootloader execution loop.

BL_I2C_Loop refers to the I2C bootloader execution loop.

BL_SPI_Loop refers to the SPI bootloader execution loop.

4 General bootloader description

4.1 Bootloader activation

The bootloader is activated by applying one of the patterns described in [Table 2](#).

If Boot from Bank2 option is activated (for products supporting this feature), bootloader executes Dual Boot mechanism as described in figures “Dual bank boot implementation for STM32xxxx” where STM32xxxx is the relative STM32 product (example: [Figure 8](#)), otherwise bootloader selection protocol is executed as described in figures “Bootloader VY.x selection for STM32xxxx” where STM32xxxx is the relative STM32 product (example: [Figure 19](#)).

When readout protection Level2 is activated, STM32 does not boot on system memory in any case and bootloader cannot be executed (unless jumping to it from Flash user code, all commands are not accessible except Get, GetID, and GetVersion).

Table 2. Bootloader activation patterns

Pattern	Condition
Pattern 1	Boot0(pin) = 1 and Boot1(pin) = 0
Pattern 2	Boot0(pin) = 1 and nBoot1(bit) = 1
Pattern 3	Boot0(pin) = 1, Boot1(pin) = 0 and BFB2(bit) = 1
	Boot0(pin) = 0, BFB2(bit) = 0 and both banks do not contain valid code
Pattern 4	Boot0(pin) = 1, Boot1(pin) = 0 and BFB2(bit) = 0 and both banks do not contain valid code
	Boot0(pin) = 1, Boot1(pin) = 0 and BFB2(bit) = 1
	Boot0(pin) = 0, BFB2(bit) = 0 and both banks do not contain valid code
Pattern 5	Boot0(pin) = 1, Boot1(pin) = 0 and BFB2(bit) = 0
	Boot0(pin) = 0, BFB2(bit) = 1 and both banks do not contain valid code
	Boot0(pin) = 1, Boot1(pin) = 0 and BFB2 (bit) = 1
Pattern 6	Boot0(pin) = 1, nBoot1(bit) = 1 and nBoot0_SW(bit) = 1
	nBoot0(bit) = 0, nBoot1(bit) = 1 and nBoot0_SW(bit) = 0
	Boot0(pin) = 0, nBoot0_SW(bit) = 1 and main Flash memory empty
	nBoot0(bit) = 1, nBoot0_SW(bit)=0 and main Flash memory empty
Pattern 7	Boot0(pin) = 1, nBoot1(bit) = 1 and BFB2(bit) = 0
	Boot0(pin) = 0, BFB2(bit) = 1 and both banks do not contain valid code
	Boot0(pin) = 1, nBoot1(bit) = 1 and BFB2(bit) = 1
Pattern 8	Boot(pin) = 0 and BOOT_ADD0(optionbyte) = 0x0040
	Boot(pin) = 1 and BOOT_ADD1(optionbyte) = 0x0040

Table 2. Bootloader activation patterns (continued)

Pattern	Condition
Pattern 9	nDBANK(bit) = 1, Boot(pin) = 0 and BOOT_ADD0(optionbyte) = 0x0040
	nDBANK(bit) = 1, Boot(pin) = 1 and BOOT_ADD1(optionbyte) = 0x0040
	nDBANK(bit) = 0, nDBOOT(bit) = 1, Boot(pin) = 0 and BOOT_ADD0(optionbyte) = 0x0040
	nDBANK(bit) = 0, nDBOOT(bit) = 1, Boot(pin) = 1 and BOOT_ADD1(optionbyte) = 0x0040
	nDBANK(bit) = 0, nDBOOT(bit) = 0, BOOT_ADDx(optionbyte) out of memory range or in ICP memory range
	nDBANK(bit) = 0, nDBOOT(bit) = 0, BOOT_ADDx(optionbyte) in Flash memory range and both banks do not contain valid code
Pattern 10	Boot(pin) = 0 and BOOT_ADD0(optionbyte) = 0x1FF0
	Boot(pin) = 1 and BOOT_ADD1(optionbyte) = 0x1FF0
Pattern 11	nBoot0(bit) = 0, nBoot1(bit) = 1, nBOOT0_SEL(bit) = 1 and BOOT_LOCK(bit) = 0
	Boot0(pin) = 1, nBoot1(bit) = 1 and nBOOT0_SEL (bit) = 0
	nBoot0(bit) = 1, nBOOT0_SEL(bit) = 1, BOOT_LOCK(bit) = 0 and main Flash memory empty
	Boot0(pin) = 0, nBOOT0_SEL(bit) = 0, BOOT_LOCK(bit) = 0 and main Flash memory empty
	BOOT_LOCK(bit) = 1 and main Flash memory empty
Pattern 12	TZen = 0, Boot0(pin) = 0, nSWBoot0(bit) = 1 and NSBOOTADD0 [24:0] = 0x017F200
	TZen = 0, Boot0(pin) = 1, nSWBoot0(bit) = 1 and NSBOOTADD1 [24:0] = 0x017F200
	TZen = 0, nBoot0(bit) = 0, nSWBoot0(bit) = 0 and NSBOOTADD1 [24:0] = 0x017F200
	TZen = 0, nBoot0(bit) = 1, nSWBoot0(bit) = 0 and NSBOOTADD0 [24:0] = 0x017F200
	TZen = 1, Boot0(pin) = 0, nSWBoot0(bit) = 1 and SECBOOTADD0 [24:0] = 0x01FF000 & RSSCMD = 0
	TZen = 1, Boot0(pin) = 1, nSWBoot0 (bit) = 1 & RSSCMD = 0, BOOT_LOCK=0 or (BOOT_LOCK = 1 and SECBOOTADD0 [24:0] = 0x01FF000)
	TZen = 1, nBoot0(bit) = 1, nSWBoot0 (bit) = 0 and SECBOOTADD0 [24:0] = 0x01FF000 & RSSCMD = 0, BOOT_LOCK=0 or (BOOT_LOCK = 1 and SECBOOTADD0 [24:0] = 0x01FF000)
	TZen = 1, nBoot0(bit) = 0, nSWBoot0 (bit) = 0 & RSSCMD = 0, BOOT_LOCK=0 or BOOT_LOCK = 1 and SECBOOTADD1 [24:0] = 0x01FF000
Pattern 13	nBoot0(bit) = 0, nBoot1(bit) = 1 and nSWBoot0(bit) = 0
	nBoot0(bit) = 1, nBoot1(bit) = 1, nSWBoot0(bit) = 0 and user Flash empty
	nBoot1(bit) = 1, nSWBoot0(bit) = 1 and Boot0(pin) = 1
	nBoot1(bit) = 1, nSWBoot0(bit) = 1, Boot0(pin) = 0 and user Flash empty

Table 2. Bootloader activation patterns (continued)

Pattern	Condition
Pattern 14	BOOT_LOCK(bit) = 0, nBoot1(bit) = 1, Boot0(pin) = 1 and nSWBoot0(bit) = 1
	BOOT_LOCK(bit) = 0, nBoot1(bit) = 1, nBoot0(bit) = 0 and nSWBoot0(bit) = 0
	BOOT_LOCK(bit) = 0, Boot0(pin) = 0, nSWBoot0(bit) = 1, BFB2(bit)=1 and both banks do not contain valid code
	BOOT_LOCK(bit) = 0, nBoot0(bit), nSWBoot0(bit) = 0, BFB2(bit)=1 and both banks do not contain valid code
Pattern 15	BOOT_LOCK(bit)=0, Boot0(pin) = 1, nBoot1(bit) = 1 and nBoot0_SW(bit) = 1
	BOOT_LOCK(bit)=0, nBoot0(bit) = 0, nBoot1(bit) = 1 and nBoot0_SW(bit) = 0
Pattern 16	Boot0(pin) = 1, nBoot1(bit) = 1 and nBoot0_SW(bit) = 1
	nBoot0(bit) = 0, nBoot1(bit) = 1 and nBoot0_SW(bit) = 0
	Boot0(pin) = 0, nBoot0_SW(bit) = 1 and main Flash memory empty

In addition to patterns described above, user can execute bootloader by performing a jump to system memory from user code. Before jumping to bootloader user must:

- Disable all peripheral clocks
- Disable used PLL
- Disable interrupts
- Clear pending interrupts

System memory boot mode can be exited by getting out from bootloader activation condition and generating hardware reset or using Go command to execute user code.

Note: When executing the Go command, the peripheral registers used by the bootloader are not initialized to their default reset values before jumping to the user application. They must be reconfigured in the user application if they are used. So, if the IWDG is being used in the application, the IWDG prescaler value has to be adapted to meet the requirements of the application (since the prescaler was set to its maximum value). For some products, not all reset values are set. For more information refer to the known limitations detailed for each product bootloader versions.

Note: For STM32 devices having the Dual Bank Boot feature, to jump to system memory from user code the user has first to remap the System Memory bootloader at address 0x00000000 using SYSCFG register (except for STM32F7 Series), then jump to bootloader. For STM32F7 Series, the user has to disable nDBOOT and/or nDBANK features (in option bytes), then jump to bootloader.

Note: For STM32 devices embedding bootloader using the DFU/CAN interface in which the external clock source (HSE) is required for DFU/CAN operations, the detection of the HSE value is done dynamically by the bootloader firmware and is based on the internal oscillator clock (HSI, MSI). When (because of temperature variations or other conditions) the internal oscillator precision is altered above the tolerance band (1% around the theoretical value), the bootloader might calculate a wrong HSE frequency value. In this case, the bootloader DFU/CAN interfaces might malfunction or not work at all.

4.2 Bootloader identification

Depending on the STM32 device used, the bootloader may support one or more embedded serial peripherals used to download the code to the internal Flash memory. The bootloader identifier (ID) provides information about the supported serial peripherals.

For a given STM32 device, the bootloader is identified by means of the:

1. **Bootloader (protocol) version:** version of the serial peripheral (e.g. USART, CAN, USB) communication protocol used in the bootloader. This version can be retrieved using the bootloader Get Version command.
2. **Bootloader identifier (ID):** version of the STM32 device bootloader, coded on one byte in the **0xXY** format, where:
 - **X** specifies the embedded serial peripheral(s) used by the device bootloader:
 - X = 1: one USART is used
 - X = 2: two USARTs are used
 - X = 3: USART, CAN and DFU are used
 - X = 4: USART and DFU are used
 - X = 5: USART and I²C are used
 - X = 6: I²C is used
 - X = 7: USART, CAN, DFU and I²C are used
 - X = 8: I²C and SPI are used
 - X = 9: USART, CAN (or FDCAN), DFU, I²C and SPI are used
 - X = 10: USART, DFU and I²C are used
 - X = 11: USART, I²C and SPI are used
 - X = 12: USART and SPI are used
 - X = 13: USART, DFU, I²C and SPI are used
 - **Y** specifies the device bootloader version
Let us take the example of a bootloader ID equal to 0x10. This means that it is the first version of the device bootloader that uses only one USART.
The bootloader ID is programmed in the last byte address - 1 of the device system memory and can be read by using the bootloader “Read memory” command or by direct access to the system memory via JTAG/SWD.

Note: The bootloader ID format is applied to all STM32 devices families except the STM32F1xx family. The bootloader version for the STM32F1xx applies only to the embedded device bootloader version and not to its supported protocols.

Table 3 provides identification information of the bootloaders embedded in STM32 devices.

Table 3. Embedded bootloaders

STM32 Series	Device		Supported serial peripherals	Bootloader ID		Bootloader (protocol) version
				ID	Memory location	
F0	STM32F05xxx/STM32F030x8		USART1/USART2	0x21	0x1FFFF7A6	USART (V3.1)
	STM32F03xx4/6		USART1	0x10	0x1FFFF7A6	USART (V3.1)
	STM32F030xC		USART1/ I2C1	0x52	0x1FFFF796	USART (V3.1) I2C1(V1.0)
	STM32F04xxx		USART1/USART2/ DFU (USB device FS)/ I2C1	0xA1	0x1FFFF6A6	USART (V3.1) DFU (V2.2) I2C (V1.0)
	STM32F071xx/072xx		USART1/USART2/ I2C1/ DFU (USB device FS)	0xA1	0x1FFFF6A6	USART (V3.1) DFU (V2.2) I2C (V1.0)
F0	STM32F070x6		USART1/USART2 / DFU (USB device FS) /I2C1	0xA2	0x1FFFF6A6	USART (V3.1) DFU (V2.2) I2C (V1.0)
	STM32F070xB		USART1/USART2/ DFU (USB device FS)/I2C1	0xA3	0x1FFFF6A6	USART (V3.1) DFU (V2.2) I2C (V1.0)
	STM32F09xxx		USART1/USART2/ I2C1	0x50	0x1FFFF796	USART (V3.1) I2C (V1.0)
F1	STM32F10xxx	Low-density	USART1	NA	NA	USART (V2.2)
		Medium-density	USART1	NA	NA	USART (V2.2)
		High-density	USART1	NA	NA	USART (V2.2)
		Medium-density value line	USART1	0x10	0x1FFFF7D6	USART (V2.2)
		High-density value line	USART1	0x10	0x1FFFF7D6	USART (V2.2)
	STM32F105xx/107xx		USART1/USART2 (remapped) / CAN2 (remapped) / DFU (USB Device)	NA	NA	USART (V2.2 ⁽¹⁾) CAN (V2.0) DFU(V2.2)
	STM32F10xxx XL-density		USART1/USART2 (remapped)	0x21	0x1FFFF7D6	USART (V3.0)
F2	STM32F2xxxx		USART1/USART3	0x20	0x1FFF77DE	USART (V3.0)
			USART1/USART3/ CAN2/ DFU (USB device FS)	0x33	0x1FFF77DE	USART (V3.1) CAN (V2.0) DFU (V2.2)

Table 3. Embedded bootloaders (continued)

STM32 Series	Device	Supported serial peripherals	Bootloader ID		Bootloader (protocol) version
			ID	Memory location	
F3	STM32F373xx	USART1/USART2/ DFU (USB device FS)	0x41	0x1FFFFFF7A6	USART (V3.1) DFU (V2.2)
	STM32F378xx	USART1/USART2/ I2C1	0x50	0x1FFFFFF7A6	USART (V3.1) I2C (V1.0)
	STM32F302xB(C)/303xB(C)	USART1/USART2/ DFU (USB device FS)	0x41	0x1FFFFFF796	USART (V3.1) DFU (V2.2)
	STM32F358xx	USART1/USART2/ I2C1	0x50	0x1FFFFFF796	USART (V3.1) I2C (V1.0)
	STM32F301xx/302x4(6/8)	USART1/USART2/ DFU (USB device FS)	0x40	0x1FFFFFF796	USART (V3.1) DFU (V2.2)
	STM32F318xx	USART1/USART2/ I2C1/ I2C3	0x50	0x1FFFFFF796	USART (V3.1) I2C (V1.0)
	STM32F302xD(E)/303xD(E)	USART1/USART2/ DFU (USB device FS)	0x40	0x1FFFFFF796	USART (V3.1) DFU (V2.2)
	STM32F303x4(6/8)/334xx/328xx	USART1/USART2/ I2C1	0x50	0x1FFFFFF796	USART (V3.1) I2C (V1.0)
	STM32F398xx	USART1/USART2/ I2C1/I2C3	0x50	0x1FFFFFF796	USART (V3.1) I2C (V1.0)

Table 3. Embedded bootloaders (continued)

STM32 Series	Device	Supported serial peripherals	Bootloader ID		Bootloader (protocol) version
			ID	Memory location	
F4	STM32F40xxx/41xxx	USART1/USART3/ CAN2/ DFU (USB device FS)	0x31	0x1FFF77DE	USART (V3.1) CAN (V2.0) DFU (V2.2)
		USART1/USART3/ CAN2 / DFU (USB device FS) /I2C1/I2C2/I2C3/ SPI1/SPI2	0x90	0x1FFF77DE	USART (V3.1) CAN (V2.0) DFU (V2.2) SPI(V1.1) I2C (V1.0)
	STM32F42xxx/43xxx	USART1/USART3/ CAN2 / DFU (USB device FS) / I2C1	0x70	0x1FFF76DE	USART (V3.1) CAN (V2.0) DFU (V2.2) I2C (V1.0)
		USART1/USART3/ CAN2 / DFU (USB device FS) / SPI1/ SPI2/ SPI4 I2C1/I2C2/I2C3/	0x91	0x1FFF76DE	USART (V3.1) CAN (V2.0) DFU (V2.2) SPI(V1.1) I2C (V1.0)
	STM32F401xB(C)	USART1/USART2/ DFU (USB device FS)/ I2C1/I2C2/I2C3/ SPI1/SPI2/ SPI3	0xD1	0x1FFF76DE	USART (V3.1) DFU (V2.2) SPI(V1.1) I2C (V1.0)
	STM32F401xD(E)	USART1/USART2/ DFU (USB device FS)/ I2C1/I2C2/I2C3/ SPI1/SPI2/ SPI3	0xD1	0x1FFF76DE	USART (V3.1) DFU (V2.2) SPI(V1.1) I2C (V1.1)
	STM32F410xx	USART1/USART2/ I2C1/I2C2/I2C4 SPI1/SPI2	0xB1	0x1FFF76DE	USART (V3.1) I2C (V1.2) SPI (V1.1)
	STM32F411xx	USART1/USART2/ DFU (USB device FS)/ SPI1/SPI2/ SPI3 I2C1/I2C2/I2C3	0xD0	0x1FFF76DE	USART (V3.1) DFU (V2.2) SPI(V1.1) I2C (V1.1)
	STM32F412xx	USART1/USART2/ USART3/CAN2/ DFU (USB device FS)/ I2C1/I2C2/I2C3/I2C4/ SPI1/SPI3/SPI4	0x91	0x1FFF76DE	USART (V3.1) CAN (V2.0) DFU (V2.2) SPI (V1.1) I2C (V1.2)
	STM32F413xx/423xx	USART1/USART2/ USART3/CAN2/ DFU (USB device FS)/ I2C1/I2C2/I2C3/I2C4/ SPI1/SPI3/SPI4	0x90	0x1FFF76DE	USART (V3.1) CAN (V2.0) DFU (V2.2) I2C (V1.2) SPI (V1.1)
	STM32F446xx	USART1/USART3/ CAN2 / DFU (USB device FS) / I2C1/I2C2/I2C3/SPI1/ SPI2/ SPI4	0x90	0x1FFF76DE	USART (V3.1) CAN (V2.0) DFU (V2.2) SPI(V1.1) I2C (V1.2)
	STM32F469xx/479xx	USART1/USART3/ I2C1/I2C2/I2C3/ CAN2/ DFU (USB device FS)/ SPI1/ SPI2/ SPI4	0x90	0x1FFF76DE	USART (V3.1) I2C (V1.2) CAN (V2.0) DFU (V2.2) SPI (V1.1)



Table 3. Embedded bootloaders (continued)

STM32 Series	Device	Supported serial peripherals	Bootloader ID		Bootloader (protocol) version
			ID	Memory location	
F7	STM32F72xxx/73xxx	USART1/USART3/ CAN1/ DFU (USB device FS)/ I2C1/I2C2/I2C3/ SPI1/SPI2/SPI4	0x90	0x1FF0EDBE	USART (V3.1) CAN (V2.0) DFU (V2.2) I2C (V1.2) SPI (V1.2)
	STM32F74xxx/75xxx	USART1/USART3/ I2C1/I2C2/I2C3/ CAN2/ DFU (USB device FS)	0x70	0x1FF0EDBE	USART (V3.1) I2C (V1.2) CAN (V2.0) DFU (V2.2)
		USART1/USART3/ I2C1/I2C2/I2C3/ CAN2/ DFU (USB device FS)/ SPI1/SPI2/SPI4	0x90	0x1FF0EDBE	USART (V3.1) I2C (V1.2) CAN (V2.0) DFU (V2.2) SPI (V1.2)
	STM32F76xxx/77xxx	USART1/USART3/ CAN2/ DFU (USB device FS)/ I2C1/I2C2/I2C3/ SPI1/SPI2/SPI4	0x93	0x1FF0EDBE	USART (V3.1) CAN (V2.0) DFU (V2.2) I2C (V1.2) SPI (V1.2)
G0	STM32G07xxx/08xxx	USART1/USART2/ USART3/I2C1/I2C2/ SPI1/SPI2	0xB2	0x1FFF6FFE	USART (V3.1) I2C (V1.2) SPI (V1.1)
	STM32G03xxx/04xxx	USART1/USART2/ I2C1/I2C2	0x53	0x1FFF1FFE	USART (V3.1) I2C (V1.2)
	STM32G0B0xx	USART1/USART2/USART3 I2C1/I2C2 SPI1/SPI2 DFU (USB Device FS)	0xD0	0x1FFF9FFE	USART (V3.1) I2C (V1.2) SPI (V1.1) DFU (V2.2)
	STM32G0B1xx/0C1xx	USART1/USART2/USART3 I2C1/I2C2 SPI1/SPI2 DFU (USB Device FS) FDCAN	0x92	0x1FFF9FFE	USART (V3.1) I2C (V1.2) SPI (V1.1) DFU (V2.2) FDCAN (V1.0)
G4	STM32G431xx/441xx	USART1/USART2/USART3 I2C2/I2C3 SPI1/SPI2 DFU (USB device FS)	0xD3	0x1FFF6FFE	USART (V3.1) I2C (V1.2) SPI (V1.1) DFU (V2.2)
	STM32G47xxx/48xxx	USART1/USART2/USART3 I2C2/I2C3/I2C4 SPI1/SPI2 DFU (USB device FS)	0xD4	0x1FFF6FFE	USART (V3.1) I2C (V1.2) SPI (V1.1) DFU (V2.2)

Table 3. Embedded bootloaders (continued)

STM32 Series	Device	Supported serial peripherals	Bootloader ID		Bootloader (protocol) version
			ID	Memory location	
H7	STM32H72xxx/73xxx	USART1/USART2/USART3 I2C1/I2C2/I2C3/ DFU (USB device FS)/ SPI1/SPI2/SPI3/SPI4/ FDCAN1	0x92	0x1FF1E7FE	USART (V3.1) I2C (V1.2) DFU (V2.2) SPI (V1.1) FDCAN (V1.0)
	STM32H74xxx/75xxx	USART1/USART2/USART3 I2C1/I2C2/I2C3/ DFU (USB device FS)/ SPI1/SPI2/SPI3/SPI4/ FDCAN1	0x90	0x1FF1E7FE	USART (V3.1) I2C (V1.1) DFU (V2.2) SPI (V1.2) FDCAN (V1.0)
	STM32H7A3xx/B3xx	USART1/USART2/USART3 I2C1/I2C2/I2C3/ DFU (USB device FS)/ SPI1/SPI2/SPI3/SPI4/ FDCAN1	0x91	0x1FF13FFE	USART (V3.1) I2C (V1.1) DFU (V2.2) SPI (V1.2) FDCAN (V1.0)
L0	STM32L01xxx/02xxx	USART2/SPI1	0xC3	0x1FF00FFE	USART (V3.1) SPI (V1.1)
	STM32L031xx/041xx	USART2/SPI1	0xC0	0x1FF00FFE	USART (V3.1) SPI (V1.1)
	STM32L05xxx/06xxx	USART1/USART2/ SPI1/ SPI2	0xC0	0x1FF00FFE	USART (V3.1) SPI (V1.1)
	STM32L07xxx/08xxx	USART1/USART2/ DFU (USB device FS)	0x41	0x1FF01FFE	USART (V3.1) DFU (V2.2)
USART1/USART2/ SPI1/SPI2/ I2C1/I2C2		0xB2	0x1FF01FFE	USART (V3.1) SPI (V1.1) I2C (V1.2)	
L1	STM32L1xxx6(8/B)	USART1/USART2	0x20	0x1FF00FFE	USART (V3.0)
	STM32L1xxx6(8/B)A	USART1/USART2	0x20	0x1FF00FFE	USART (V3.1)
	STM32L1xxxC	USART1/USART2/ DFU (USB device FS)	0x40	0x1FF01FFE	USART (V3.1) DFU (V2.2)
	STM32L1xxxD	USART1/USART2/ DFU (USB device FS)	0x45	0x1FF01FFE	USART (V3.1) DFU (V2.2)
	STM32L1xxxE	USART1/USART2/ DFU (USB device FS)	0x40	0x1FF01FFE	USART (V3.1) DFU (V2.2)

Table 3. Embedded bootloaders (continued)

STM32 Series	Device	Supported serial peripherals	Bootloader ID		Bootloader (protocol) version
			ID	Memory location	
L4	STM32L412xx/422xx	USART1/USART2/USART3 I2C1/I2C2/I2C3/ DFU (USB device FS)/ SPI1/SPI2	0xD1	0x1FFF6FFE	USART (V3.1) I2C (V1.2) DFU (V2.2) SPI (V1.1)
	STM32L43xxx/44xxx	USART1/USART2/USART3/ I2C1/I2C2/I2C3/ CAN1/ DFU (USB device FS)/ SPI1/SPI2	0x91	0x1FFF6FFE	USART (V3.1) I2C (V1.2) CAN (V2.0) DFU (V2.2) SPI (V1.1)
	STM32L45xxx/46xxx	USART1/USART2/USART3/ I2C1/I2C2/I2C3/ CAN1/ DFU (USB device FS)/ SPI1/SPI2	0x92	0x1FFF6FFE	USART (V3.1) I2C (V1.2) CAN (V2.0) DFU (V2.2) SPI (V1.1)
	STM32L47xxx/48xxx	USART1/USART2/ USART3/ I2C1/I2C2/I2C3/ DFU (USB device FS)	0xA3	0x1FFF6FFE	USART (V3.1) I2C (V1.2) DFU (V2.2)
		USART1/USART2/ USART3/ I2C/I2C2/I2C3/ SPI1/SPI2/ CAN1/ DFU (USB device FS)	0x92	0x1FFF6FFE	USART (V3.1) I2C (V1.2) SPI (V1.1) CAN(V2.0) DFU(V2.2)
	STM32L496xx/4A6xx	USART1/USART2/USART3/ I2C1/I2C2/I2C3/ CAN1/ DFU (USB device FS)/ SPI1/SPI2	0x93	0x1FFF6FFE	USART (V3.1) I2C (V1.2) CAN (V2.0) DFU (V2.2) SPI (V1.1)
	STM32L4Rxxx/STM32L4Sxxx	USART1/USART2/USART3/ I2C1/I2C2/I2C3/ CAN1/ DFU (USB device FS)/ SPI1/SPI2	0x95	0x1FFF6FFE	USART (V3.1) I2C (V1.2) CAN (V2.0) DFU (V2.2) SPI (V1.1)
STM32L4P5xx /Q5xx	USART1/USART2/USART3 I2C1/I2C2/I2C3/ CAN1/ DFU (USB device FS)/ SPI1/SPI2	0x90	0x1FFF6FFE	USART (V3.1) I2C (V1.2) CAN (V2.0) DFU (V2.2) SPI (V1.1)	
L5	STM32L552xx/562xx	USART1/USART2/USART3 I2C1/I2C2/I2C3 SPI1/SPI2/SPI3 DFU (USB device FS) FDCAN1	0x92	0x0BF97FFE	USART (V3.1) I2C (V1.2) SPI (V1.1) DFU (V2.2) FDCAN (V1.0)

Table 3. Embedded bootloaders (continued)

STM32 Series	Device	Supported serial peripherals	Bootloader ID		Bootloader (protocol) version
			ID	Memory location	
WB	STM32WB30xx/35xx/50xx/55xx	USART1/ I2C1/I2C3 SPI1/SPI2 DFU (USB device FS)	0xD5	0x1FFF6FFE	USART (V3.2) I2C (V1.2) SPI (V1.1) DFU (V2.2)
WL	STM32WLE5xx/55xx	USART1/USART2 SPI1/SPI2	0xC3	0x1FF36EFE	USART (V3.1) SPI (V1.1)

1. For connectivity line devices, the USART bootloader returns V2.0 instead of V2.2 for the protocol version. For more details refer to the "STM32F105xx and STM32F107xx revision Z" errata sheet available from www.st.com.

4.3 Hardware connection requirements

To use the USART bootloader, the host must be connected to the RX and TX pins of the desired USARTx interface via a serial cable.

Figure 1. USART connection

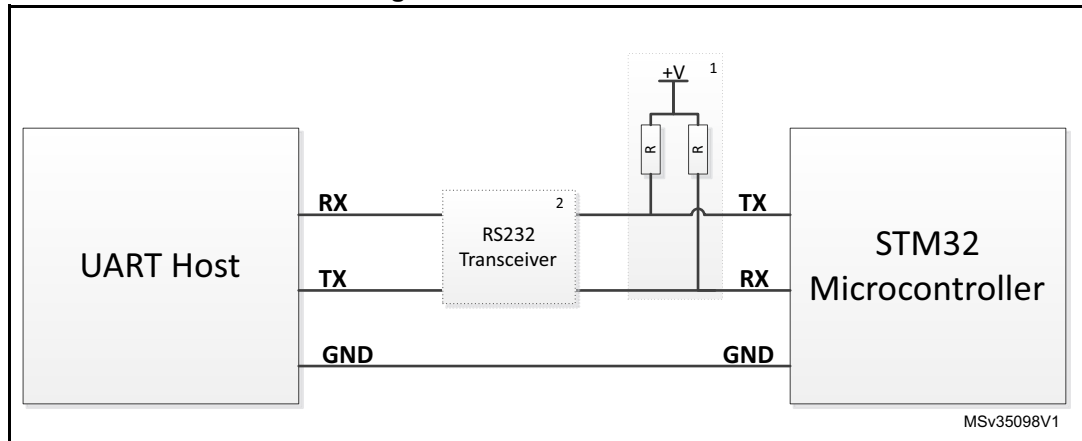

1. A pull-up resistor must be added, if pull-up resistor are not connected in host side.
2. An RS232 transceiver must be connected to adapt voltage level (3.3 to 12 V) between STM32 device and host.

Note: +V typically is 3.3 V and R typically 100 K Ω . These values depend upon the application and the used hardware.

To use the DFU, connect the microcontroller USB interface to a USB host (i.e. a PC).

Figure 2. USB connection

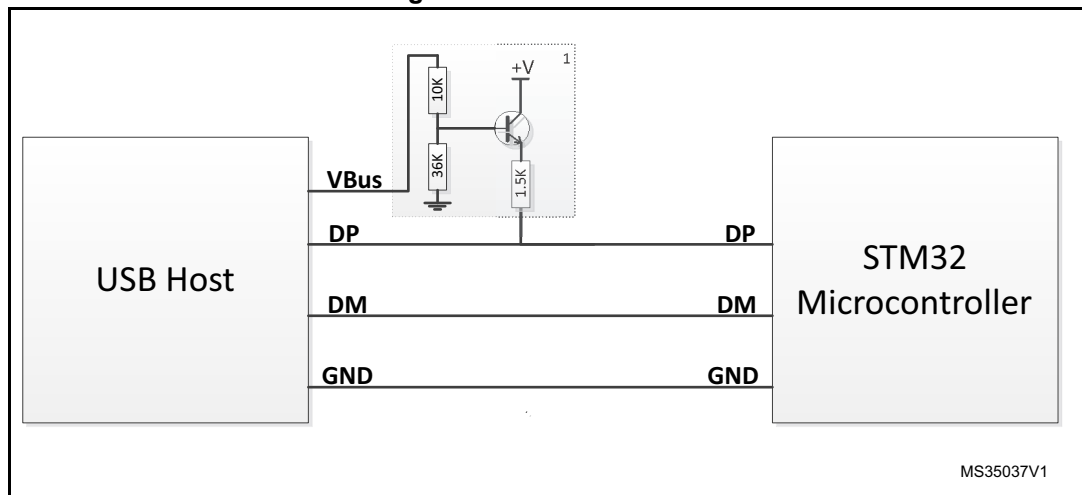

1. This additional circuit permits to connect a pull-up resistor to DP pin using VBus when needed. Refer to product section (table describing STM32 configuration in system memory boot mode) to know if an external pull-up resistor must be connected to DP pin.

Note: +V typically is 3.3 V. This value depends upon the application and the used hardware.

To use the I2C bootloader, connect the host (master) and the desired I2Cx interface (slave) together via the data (SDA) and clock (SCL) pins. A 1.8 K Ω pull-up resistor has to be connected to both SDA and SCL lines.

Figure 3. I2C connection

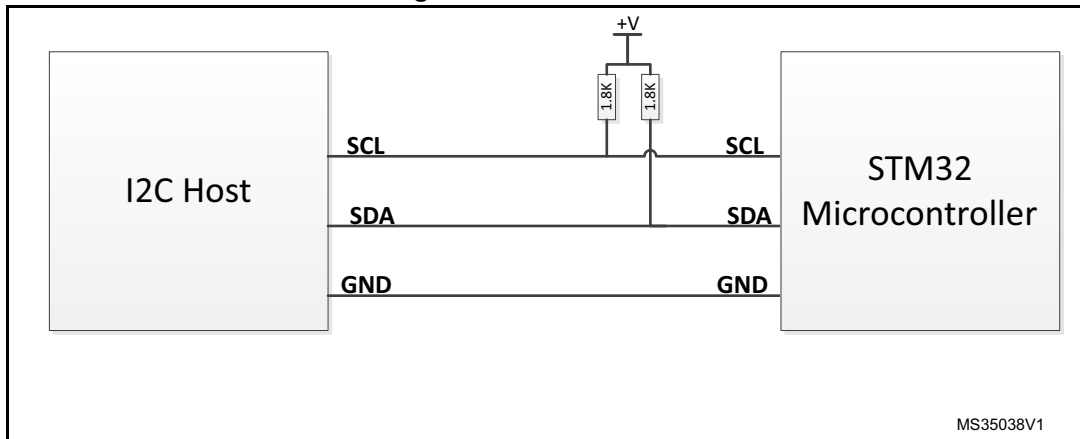

Note: +V is typically 3.3 V. This value depends upon the application and the used hardware.

To use the SPI bootloader, connect the host (master) and the desired SPIx interface (slave) together via the MOSI, MISO and SCK pins. The NSS pin must be connected to GND. A pull-down resistor must be connected to the SCK line.

Figure 4. SPI connection

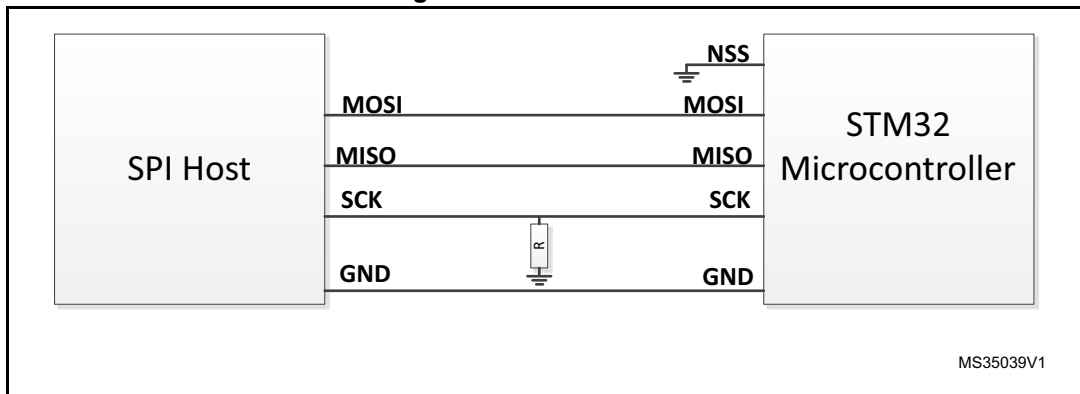

Note: R is typically 10 KΩ. This value depends on the application and the used hardware.

To use the CAN interface, the host has to be connected to the RX and TX pins of the desired CANx interface via CAN transceiver and a serial cable. A 120 Ω resistor must be added as terminating resistor.

Figure 5. CAN connection

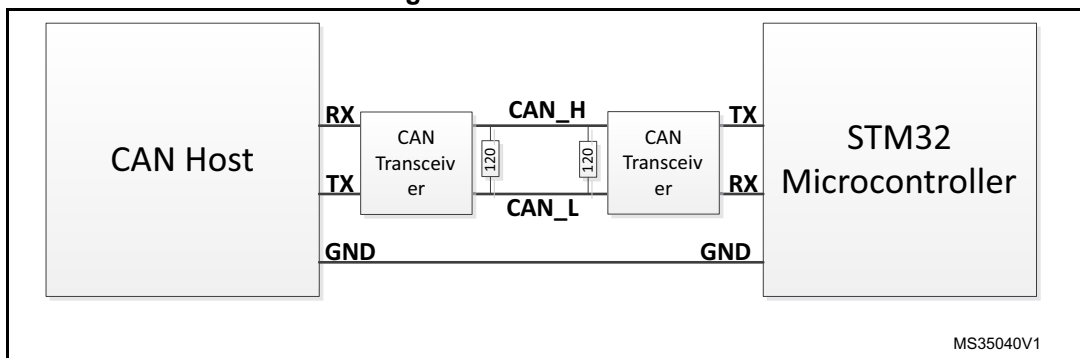

Note: When a bootloader firmware supports DFU, it is mandatory that no USB Host is connected to the USB peripheral during the selection phase of the other interfaces. After selection phase, the user can plug a USB cable without impacting the selected bootloader execution except commands which generate a system reset.

It is recommended to keep the RX pins of unused bootloader interfaces (USART_RX, SPI_MOSI, CAN_RX and USB D+/D- lines if present) at a known (low or high) level at the startup of the bootloader (detection phase). Leaving these pins floating during the detection phase might lead to activating unused interfaces.

4.4 Bootloader memory management

All write operations using bootloader commands must only be Word-aligned (the address must be a multiple of 4). The number of data to be written must also be a multiple of 4 (non-aligned half page write addresses are accepted).

Some Products embed bootloader that has some specific features:

- Some products do not support Mass erase operation. To perform a mass erase operation using bootloader, two options are available:
 - Erase all sectors one by one using the Erase command
 - Set protection level to Level 1. Then, set it to Level 0 (using the Read protect command and then the Read Unprotect command). This operation results in a mass erase of the internal Flash memory.
- Bootloader firmware of STM32 L1 and L0 series supports Data Memory in addition to standard memories (internal Flash, internal SRAM, option bytes and System memory). The start address and the size of this area depends on product, refer to product reference manual for more information. Data memory can be read and written but cannot be erased using the Erase Command. When writing in a Data memory location, the bootloader firmware manages the erase operation of this location before any write. A write to Data memory must be Word-aligned (address to be written must be a multiple of 4) and the number of data must also be a multiple of 4. To erase a Data memory location, write zeros at this location.
- Bootloader firmware of STM32 F2, F4, F7 and L4 series supports OTP memory in addition to standard memories (internal Flash, internal SRAM, option bytes and System memory). The start address and the size of this area depends on product, refer to product reference manual for more information. OTP memory can be read and written but cannot be erased using Erase command. When writing in an OTP memory location, make sure that the relative protection bit is not reset.
- For STM32 F2, F4 and F7 series the internal Flash memory write operation format depends on voltage Range. By default write operation are allowed by one byte format (Half-Word, Word and Double-Word operations are not allowed). to increase the speed of write operation, the user must apply the adequate voltage range that allows write operation by Half-Word, Word or Double-Word and update this configuration on the fly by the bootloader software through a virtual memory location. This memory location is not physical but can be read and written using usual bootloader read/write operations according to the protocol in use. This memory location contains 4 bytes described in [Table 4](#). It can be accessed by 1, 2, 3 or 4 bytes. However, reserved bytes must remain at their default values (0xFF), otherwise the request is NACKed.

Table 4. STM32 F2, F4 and F7 voltage range configuration using bootloader

Address	Size	Description
0xFFFF0000	1 byte	This byte controls the current value of the voltage range. 0x00: voltage range [1.8 V, 2.1 V] 0x01: voltage range [2.1 V, 2.4 V] 0x02: voltage range [2.4 V, 2.7 V] 0x03: voltage range [2.7 V, 3.6 V] 0x04: voltage range [2.7 V, 3.6 V] and double word write/erase operation is used. In this case it is mandatory to supply 9 V through the VPP pin (refer to the product reference manual for more details about the double-word write procedure). Other: all other values are not supported and are NACKed.
0xFFFF0001	1 byte	Reserved. 0xFF: default value. Other: all other values are not supported and are NACKed.
0xFFFF0002	1 byte	Reserved. 0xFF: default value. Other: all other values are not supported and is NACKed.
0xFFFF0003	1 byte	Reserved. 0xFF: default value. Other: all other values are not supported and are NACKed.

The table below lists the valid memory areas, depending upon the bootloader commands.

Table 5. Supported memory area by Write, Read, Erase and Go commands

Memory area	Write command	Read command	Erase command	Go command
Flash	Supported	Supported	Supported	Supported
RAM	Supported	Supported	Not supported	Supported
System memory	Not supported	Supported	Not supported	Not supported
Data memory	Supported	Supported	Not supported	Not supported
OTP memory	Supported	Supported	Not supported	Not supported

4.5 Bootloader UART baudrate detection

For the UART interface baudrate detection, there are two types of mechanisms implemented on different STM32 devices:

- Software baudrate detection using internal HSI and timer (use GPIO as input, detect falling edge and rising edge as explained in AN3155).
The devices using this mechanism are subject to software jitter (variable error of baudrate calculation) that can reach up to $\pm 5\%$.
So, in that case, the host connecting to the STM32 bootloader UART interface shall support a deviation in baudrate equivalent to $\pm 5\%$.
The software jitter value is variable and is different at each retry, so it is possible to use multiple retry connections in order to overcome the software jitter (connect and check for correct bootloader answer, if answer is not correct, reset the device and retry)

connection until the correct answer is received. Once correct answer is received the rest of the communication is not impacted by software jitter).

It is also possible to reduce software jitter by reducing baudrate value (i.e. use 56000 bps instead of 115200).

[Table 6](#) provides the maximum software jitter value for the baudrate 115200 bps. The lower the baudrate the lower the software jitter.

- Baudrate detection using UART auto-baudrate feature. The devices using this mechanism do not present any software jitter.

Table 6. Jitter software calculation on bootloader USART detection

Series	Baudrate detection method	Maximum software jitter for 115200 bps
STM32F0	Software baudrate detection	-1%
STM32F1	Software baudrate detection	-3%
STM32F2	Software baudrate detection	-5%
STM32F3	Software baudrate detection	-2%
STM32F4	Software baudrate detection	-6%
STM32F7	Software baudrate detection	-6%
STM32L0	Software baudrate detection	-2%
STM32L1	Software baudrate detection	-3%
STM32L4	Software baudrate detection	-5%
STM32G07x/8x UART3 STM32G03x/4x UART2	Software baudrate detection	-4%
STM32G07x/8x UART1/UART2 STM32G03x/4x UART1	Auto-baudrate	N/A
STM32G4	Auto-baudrate	N/A
STM32H7	Auto-baudrate	N/A
STM32WB	Auto-baudrate	N/A
STM32WL	Auto-baudrate	N/A

4.6 Programming constraints

When using bootloader interface to write in the Flash memory, alignment on the programmed address must be respected according to [Table 7](#).

If the address to which the write operation is not aligned, then it fails and all following program operations fail as well.

Table 7. Flash memory alignment constraints on STM32 products

Series	Alignment
STM32F0	4 bytes
STM32F1	4 bytes

Table 7. Flash memory alignment constraints on STM32 products (continued)

Series	Alignment
STM32F2	4 bytes
STM32F3	4 bytes
STM32F4	4 bytes
STM32F7	8 bytes
STM32L0	8 bytes
STM32L1	8 bytes
STM32L4	8 bytes
STM32G0	4 bytes
STM32G4	4 bytes
STM32H7	8 bytes
STM32WB	8 bytes
STM32WL	8 bytes

Example of alignment:

- 4 bytes: 0x08000014 is aligned and passes, 0x08000012 is not aligned and fails
- 8 bytes: 0x08000010 is aligned and passes, 0x08000014 is not aligned and fails

Note: On some products (STM32F4 and STM32F7) it is possible to change the alignment constraint by writing in the device feature space.

4.7 ExitSecureMemory feature

The securable memory area is used to isolate secure boot code/data, which handle sensitive information (secrets), from application code:

- Access is controlled by a securable memory bit SEC_PROT (write once), in the FLASH_CR register
- Executed once at boot then locked by writing the securable memory bit
 - The code protected: in the securable memory area is hidden until the next reset that unlocks the SEC_PROT bit
- Width (number of Flash memory pages) is defined through an option byte, SEC_SIZE, in the Flash memory FLASH_SEC_R register

The ExitSecureMemory is a software developed and hosted on the system memory. When the user boot code jump to it, the software allows setting the SEC_PROT bit to “1” and then jumping to the application code. The SEC_SIZE must be set to the needed value before jumping to the ExitSecureMemory function.

As shown in [Figure 6](#), two jump methods can be used by the customer:

Jump to the secure memory function without parameter

In this case the application must be loaded just after the secure memory defined.

Jump to the secure memory function using two parameters

1. Magic number
 - 0x08192A3C
 - Used to secure boot code/data in Flash and jump in case of a single bank product
 - Used to secure boot code/data in Bank1 and jump in case of a dual bank product
 - 0x08192A3D
 - Used to secure boot code/data and jump to application in Bank2 in case of a dual bank product
2. User address = Application address
 - In this case the application can be loaded to any desired address (as per user address defined)

Figure 6. ExitSecureMemory function usage

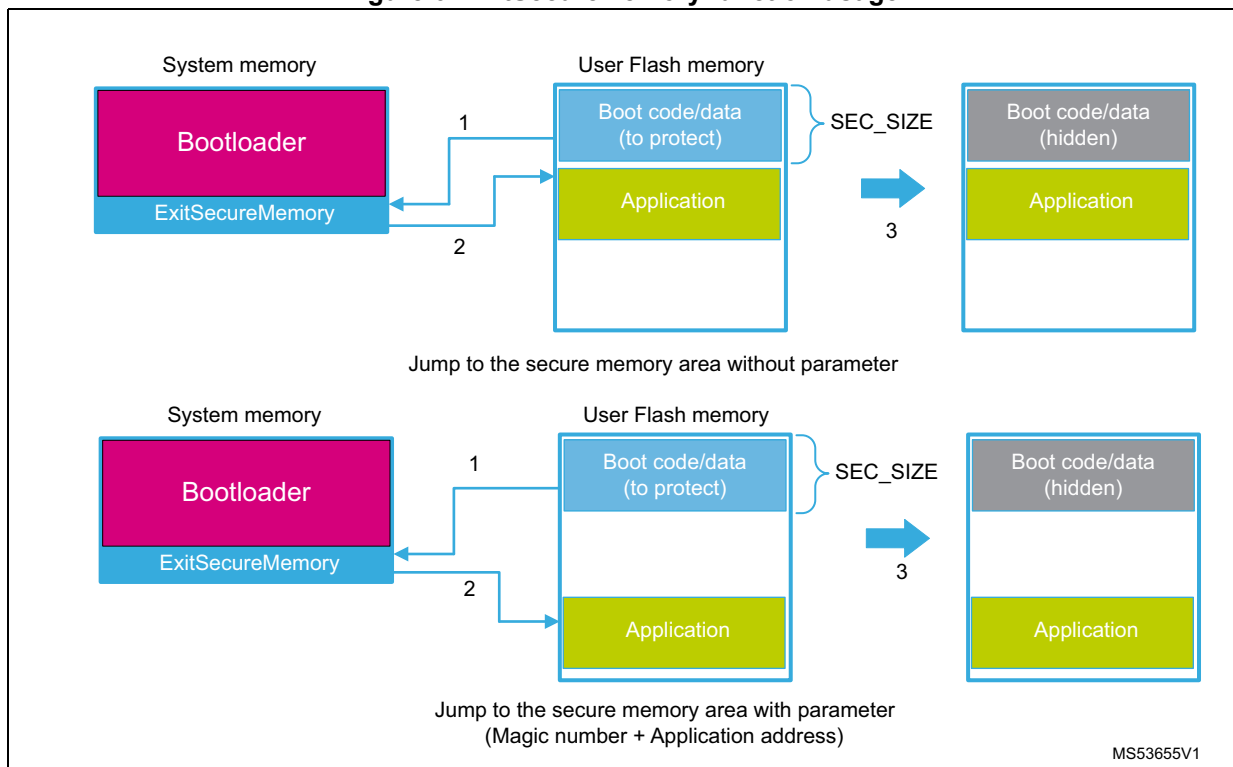

Note: For more information regarding the option bytes configuration refer to the reference manual.

Note: An example of a function that can be used to call the “ExitSecureMemory” is in [Appendix A](#).

Table 8. ExitSecureMemory entry address

MCU		ExitSecureMemory address
STM32G0	STM32G07xxx/08xxx	0x1FFF6800
	STM32G03xxx/04xxx	0x1FFF1E00
	STM32G0Bxxx/0Cxxx	0x1FFF6800

Table 8. ExitSecureMemory entry address (continued)

MCU		ExitSecureMemory address
STM32G4	STM32G47xxx/48xxx	0x1FFF6800
	STM32G431xx/441xx	0x1FFF6800

For more details refer to [Figure 7](#).

Figure 7. Access to securable memory area from the bootloader

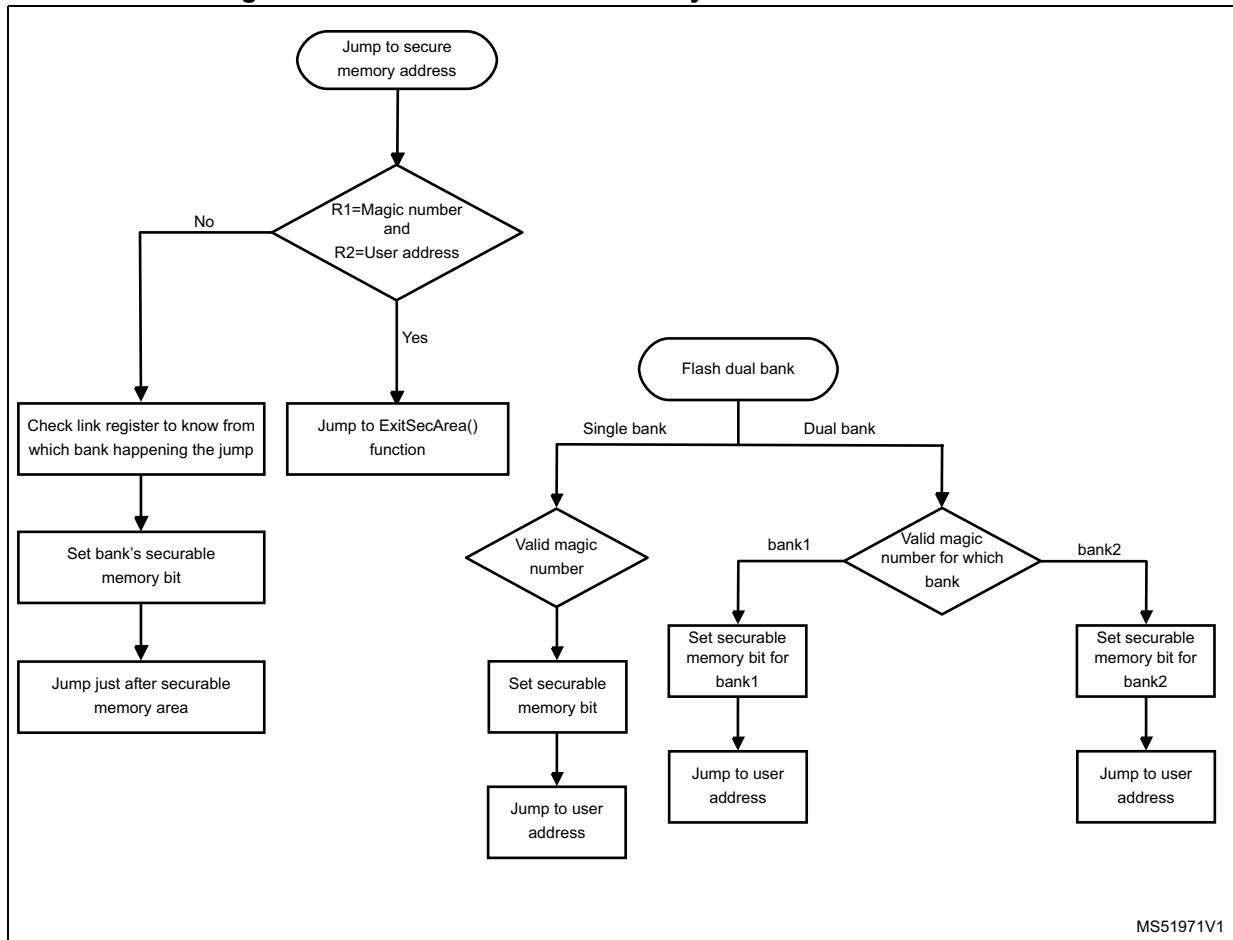

1. The Bootloader does not check the integrity of the user address, it is up to the user to ensure the validity of the address to jump to.

5 STM32F03xx4/6 devices bootloader

5.1 Bootloader configuration

The STM32F03xx4/6 bootloader is activated by applying Pattern 2 (see [Table 2: Bootloader activation patterns](#)). [Table 9](#) shows the hardware resources used by this bootloader.

Table 9. STM32F03xx4/6 configuration in system memory boot mode

Bootloader	Feature/Peripheral	State	Comment
Common to all bootloaders	RCC	HSI enabled	The system clock frequency is 24 MHz (using PLL clocked by HSI). 1 Flash Wait State.
	RAM	-	2 Kbyte starting from address 0x20000000 are used by the bootloader firmware.
	System memory	-	3 Kbyte starting from address 0x1FFFE000 contain the bootloader firmware.
	IWDG	-	The independent watchdog (IWDG) prescaler is configured to its maximum value. It is periodically refreshed to prevent watchdog reset in case the hardware IWDG option was previously enabled by the user.
USART1 bootloader (on PA10/PA9)	USART1	Enabled	Once initialized, the USART1 configuration is 8 bits, even parity and 1 Stop bit.
	USART1_RX pin	Input	PA10 pin: USART1 in reception mode.
	USART1_TX pin	Output	PA9 pin: USART1 in transmission mode.
USART1 bootloader (on PA14/PA15)	USART1	Enabled	Once initialized, the USART1 configuration is 8 bits, even parity and 1 Stop bit.
	USART1_RX pin	Input	PA15 pin: USART1 in reception mode.
	USART1_TX pin	Output	PA14 pin: USART1 in transmission mode.
USART1 bootloaders	SysTick timer	Enabled	Used to automatically detect the serial baud rate from the host.

The system clock is derived from the embedded internal high-speed RC, no external quartz is required for the bootloader execution.

Note: After the STM32F03xx4/6 devices has booted in bootloader mode, serial wire debug (SWD) communication is no longer possible until the system is reset. This is because the SWD uses the PA14 pin (SWCLK) which is already used by the bootloader (USART1_TX).

5.2 Bootloader selection

Figure 8 shows the bootloader selection mechanism.

Figure 8. Bootloader selection for STM32F03xx4/6 devices

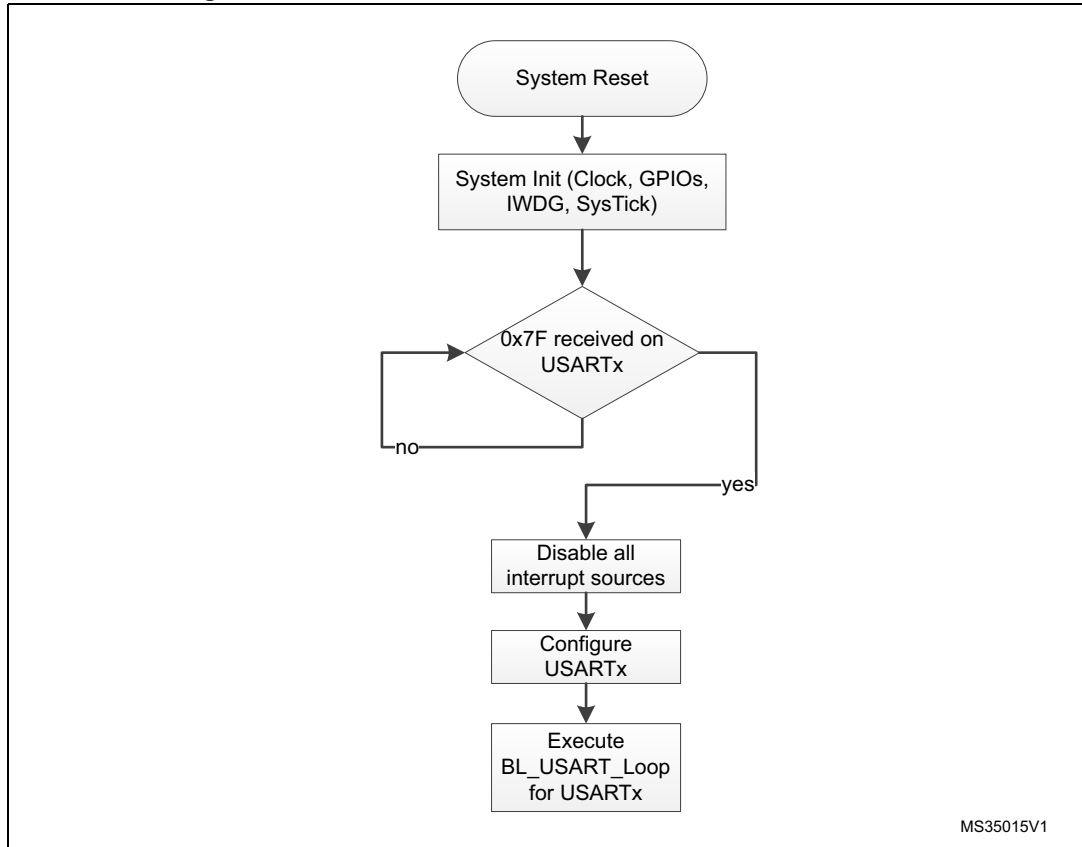

5.3 Bootloader version

The following table lists the STM32F03xx4/6 devices bootloader versions.

Table 10. STM32F03xx4/6 bootloader versions

Bootloader version number	Description	Known limitations
V1.0	Initial bootloader version	For the USART interface, two consecutive NACKs instead of 1 NACK are sent when a Read Memory or Write Memory command is sent and the RDP level is active.

6 STM32F030xC devices bootloader

6.1 Bootloader configuration

The STM32F030xC bootloader is activated by applying Pattern 2 (see [Table 2: Bootloader activation patterns](#)). [Table 11](#) shows the hardware resources used by this bootloader.

Table 11. STM32F030xC configuration in system memory boot mode

Bootloader	Feature/Peripheral	State	Comment
Common to all bootloaders	RCC	HSI enabled	The system clock frequency is 48 MHz with HSI 8 MHz as clock source.
	RAM	-	6 Kbyte starting from address 0x20000000 are used by the bootloader firmware
	System memory	-	8 Kbyte starting from address 0x1FFFD800, contain the bootloader firmware.
USART1 bootloader	USART1	Enabled	Once initialized the USART1 configuration is: 8-bit, even parity and 1 Stop bit
	USART1_RX pin	Input	PA10 pin: USART1 in reception mode
	USART1_TX pin	Output	PA9 pin: USART1 in transmission mode
USART2 bootloader	USART2	Enabled	Once initialized the USART2 configuration is: 8-bit, even parity and 1 Stop bit
	USART2_RX pin	Input	PA15 pin: USART2 in reception mode
	USART2_TX pin	Output	PA14 pin: USART2 in transmission mode
USARTx bootloaders	SysTick timer	Enabled	Used to automatically detect the serial baud rate from the host for USARTx bootloaders.
I2C1 bootloader	I2C1	Enabled	The I2C1 configuration is: I2C speed: up to 400 kHz, 7-bit address, slave mode, analog filter ON. Slave 7-bit address: 0b1000001x (where x = 0 for write and x = 1 for read)
	I2C1_SCL pin	Input/Output	PB6 pin: clock line is used in open-drain mode.
	I2C1_SDA pin	Input/Output	PB7 pin: data line is used in open-drain mode.

Note: After the STM32F030xC devices have booted in bootloader mode using USART2, the serial wire debug (SWD) communication is no more possible until the system is reset, because SWD uses PA14 pin (SWCLK) which is already used by the bootloader (USART2_RX).

The system clock is derived from the embedded internal high-speed RC, no external quartz is required for the bootloader execution.

6.2 Bootloader selection

Figure 9 shows the bootloader selection mechanism.

Figure 9. Bootloader selection for STM32F030xC

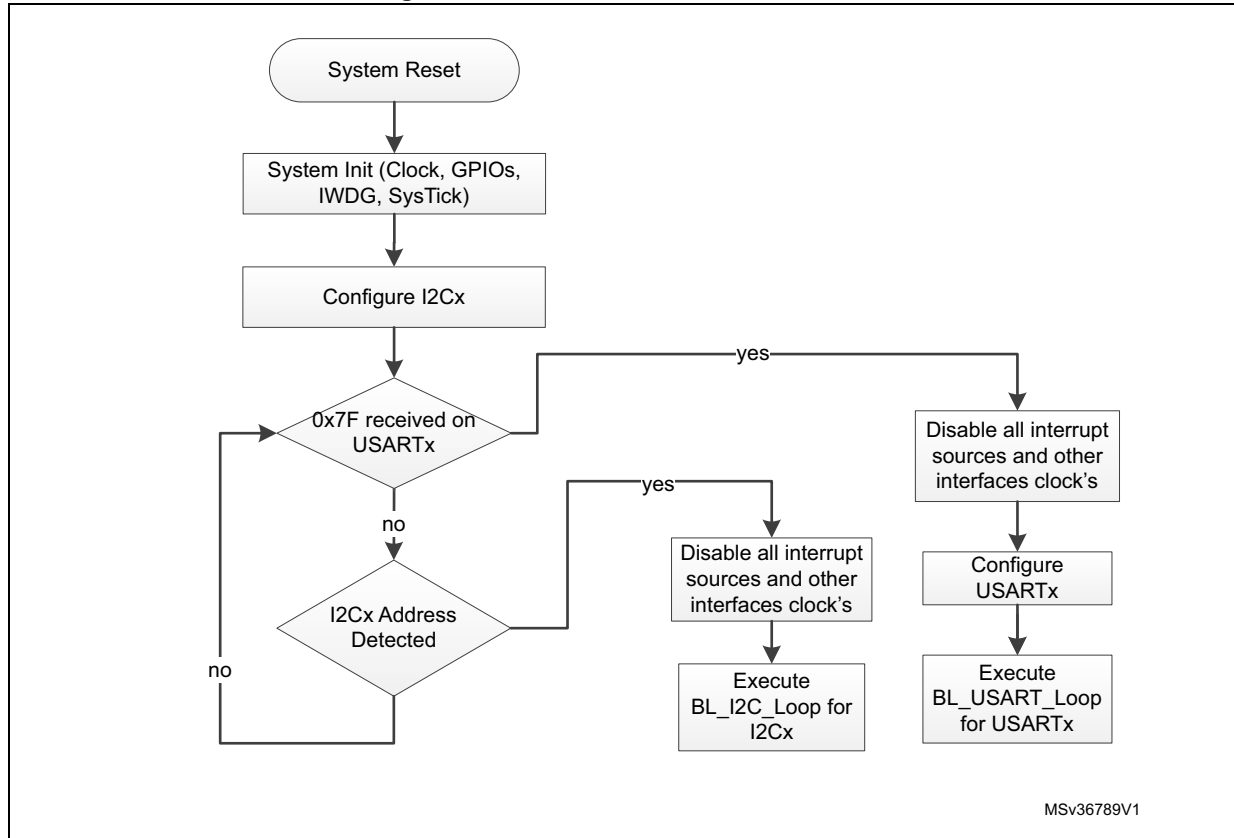

6.3 Bootloader version

Table 12 lists the STM32F030xC devices bootloader versions.

Table 12. STM32F030xC bootloader versions

Bootloader version number	Description	Known limitations
V5.2	Initial bootloader version	None

7 STM32F05xxx and STM32F030x8 devices bootloader

7.1 Bootloader configuration

The STM32F05xxx and STM32F030x8 devices bootloader is activated by applying Pattern 2 (described in [Table 2: Bootloader activation patterns](#)). [Table 13](#) shows the hardware resources used by this bootloader.

Table 13. STM32F05xxx and STM32F030x8 devices configuration in system memory boot mode

Bootloader	Feature/Peripheral	State	Comment
Common to all bootloaders	RCC	HSI Enabled	The system clock frequency is 24 MHz (using PLL clocked by HSI). 1 Flash Wait State.
	RAM	-	2 Kbyte starting from address 0x20000000 are used by the bootloader firmware.
	System memory	-	3 Kbyte starting from address 0x1FFFEC00, contain the bootloader firmware.
	IWDG	-	The independent watchdog (IWDG) prescaler is configured to its maximum value. It is periodically refreshed to prevent watchdog reset in case the hardware IWDG option was previously enabled by the user.
USART1 bootloader	USART1	Enabled	Once initialized, the USART1 configuration is 8 bits, even parity and 1 Stop bit.
	USART1_RX pin	Input	PA10 pin: USART1 in reception mode.
	USART1_TX pin	Output	PA9 pin: USART1 in transmission mode.
USART2 bootloader	USART2	Enabled	Once initialized, the USART2 configuration is 8 bits, even parity and 1 Stop bit.
	USART2_RX pin	Input	PA15 pin: USART2 in reception mode.
	USART2_TX pin	Output	PA14 pin: USART2 in transmission mode.
USARTx bootloaders	SysTick timer	Enabled	Used to automatically detect the serial baud rate from the host.

The system clock is derived from the embedded internal high-speed RC, no external quartz is required for the bootloader execution.

Note: After the STM32F05xxx and STM32F030x8 devices have booted in bootloader mode, the serial wire debug (SWD) communication is no more possible until the system is reset, because SWD uses PA14 pin (SWCLK), already used by the bootloader (USART2_TX).

7.2 Bootloader selection

Figure 10 shows the bootloader selection mechanism.

Figure 10. Bootloader selection for STM32F05xxx and STM32F030x8 devices

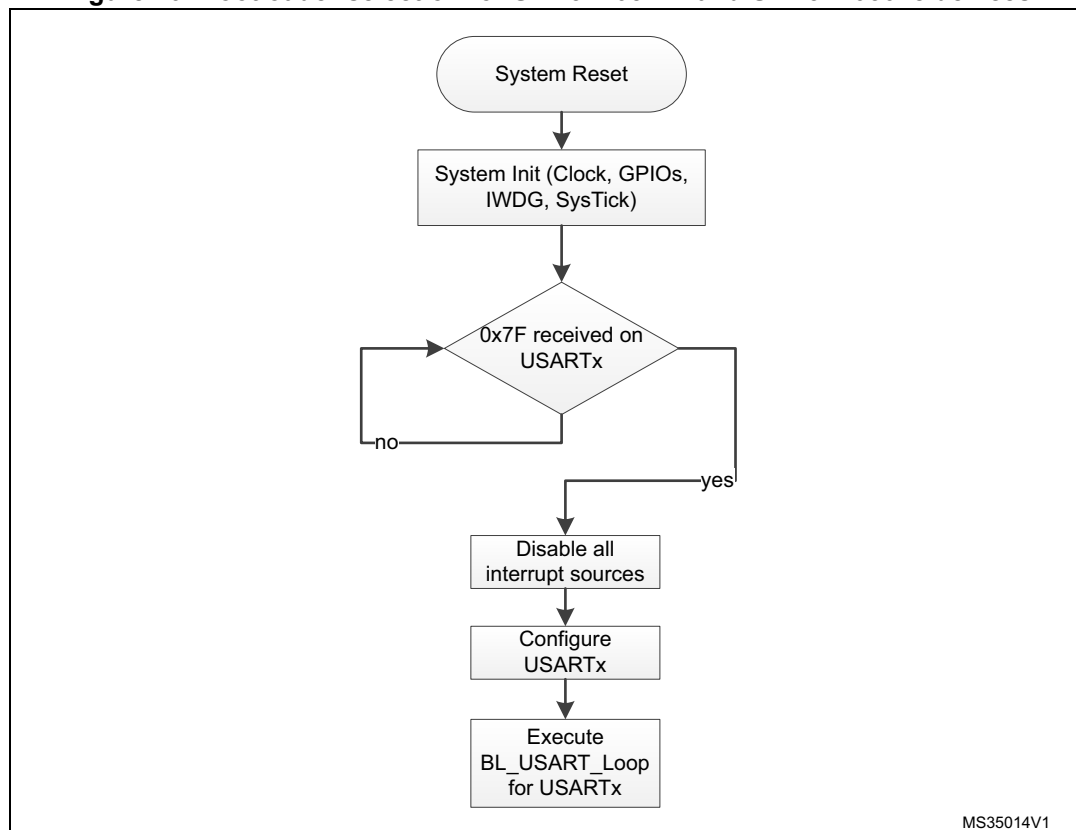

7.3 Bootloader version

Table 14 lists the STM32F05xxx and STM32F030x8 devices bootloader versions.

Table 14. STM32F05xxx and STM32F030x8 devices bootloader versions

Bootloader version number	Description	Known limitations
V2.1	Initial bootloader version	<ul style="list-style-type: none"> – At bootloader startup, the HSITRIM value is set to 0 (in HSITRIM bits on RCC_CR register) instead of default value (16), as a consequence a deviation is generated in crystal measurement. For better results, use the smallest supported crystal value (i.e. 4 MHz). – For the USART interface, two consecutive NACKs instead of 1 NACK are sent when a Read Memory or Write Memory command is sent and the RDP level is active.

8 STM32F04xxx devices bootloader

8.1 Bootloader configuration

The STM32F04xxx bootloader is activated by applying Pattern 6 (described in [Table 2: Bootloader activation patterns](#)). [Table 15](#) shows the hardware resources used by this bootloader.

Table 15. STM32F04xxx configuration in system memory boot mode

Bootloader	Feature/Peripheral	State	Comment
Common to all bootloaders	RCC	HSI enabled	The system clock frequency is 48 MHz with HSI48 48 MHz as clock source.
		-	The clock recovery system (CRS) is enabled for the DFU bootloader to allow USB to be clocked by HSI48 48 MHz.
	RAM	-	6 Kbyte starting from address 0x20000000 are used by the bootloader firmware
	System memory	-	13 Kbyte starting from address 0x1FFFC400, contain the bootloader firmware
	IWDG	-	The independent watchdog (IWDG) prescaler is configured to its maximum value. It is periodically refreshed to prevent watchdog reset (in case the hardware IWDG option was previously enabled by the user).
USART1 bootloader	USART1	Enabled	Once initialized the USART1 configuration is: 8-bit, even parity and 1 Stop bit
	USART1_RX pin	Input	PA10 pin: USART1 in reception mode
	USART1_TX pin	Output	PA9 pin: USART1 in transmission mode
USART2 bootloader	USART2	Enabled	Once initialized the USART2 configuration is: 8-bit, even parity and 1 Stop bit
	USART2_RX pin	Input	PA15 pin: USART2 in reception mode
	USART2_TX pin	Output	PA14 pin: USART2 in transmission mode
USARTx bootloaders	SysTick timer	Enabled	Used to automatically detect the serial baud rate from the host for USARTx bootloaders.
I2C1 bootloader	I2C1	Enabled	The I2C1 configuration is: I2C speed: up to 400 kHz, 7-bit address, slave mode, analog filter ON. Slave 7-bit address: 0b0111110x (where x = 0 for write and x = 1 for read).
	I2C1_SCL pin	Input/Output	PB6 pin: clock line is used in open-drain mode.
	I2C1_SDA pin	Input/Output	PB7 pin: data line is used in open-drain mode.

Table 15. STM32F04xxx configuration in system memory boot mode (continued)

Bootloader	Feature/Peripheral	State	Comment
DFU bootloader	USB	Enabled	USB used in FS mode
	USB_DM pin	Input/Output	PA11: USB DM line.
	USB_DP pin		PA12: USB DP line No external pull-up resistor is required.

Note: After the STM32F04xxx devices have booted in bootloader mode using USART2, the serial wire debug (SWD) communication is no more possible until the system is reset, because SWD uses PA14 pin (SWCLK) which is already used by the bootloader (USART2_RX).

The system clock is derived from the embedded internal high-speed RC, no external quartz is required for the bootloader execution.

Note: Due to empty check mechanism present on this product, it is not possible to jump from user code to system bootloader. Such jump results in a jump back to user Flash memory space. But if the first 4 bytes of User Flash (at 0x0800 0000) are empty at the moment of jump (i.e. erase first sector before jump or execute code from SRAM while Flash is empty), then system bootloader is executed when jumped to.

8.2 Bootloader selection

Figure 11 shows the bootloader selection mechanism.

Figure 11. Bootloader selection for STM32F04xxx

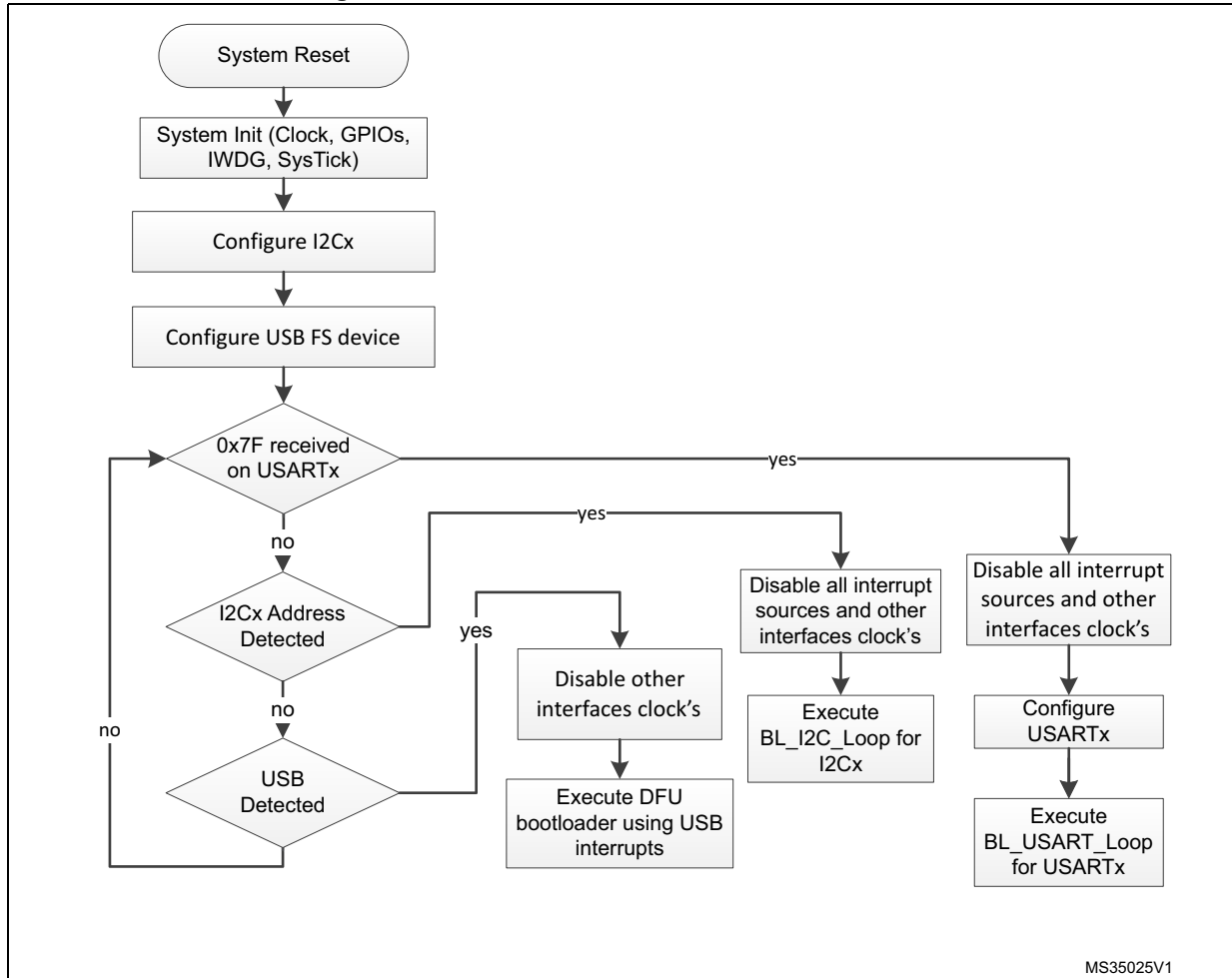

8.3 Bootloader version

The following table lists the STM32F04xxx devices bootloader versions:

Table 16. STM32F04xxx bootloader versions

Bootloader version number	Description	Known limitations
V10.0	Initial bootloader version	At bootloader startup, the HSITRIM value is set to 0 (in HSITRIM bits on RCC_CR register) instead of default value (16), as a consequence a deviation is generated in crystal measurement.
V10.1	Add dynamic support of USART/USB interfaces on PA11/12 IOs for small packages.	For better results, use the smallest supported crystal value (i.e. 4 MHz).

9 STM32F070x6 devices bootloader

9.1 Bootloader configuration

The STM32F070x6 bootloader is activated by applying Pattern 6 (described in [Table 2: Bootloader activation patterns](#)). [Table 17](#) shows the hardware resources used by this bootloader.

Table 17. STM32F070x6 configuration in system memory boot mode

Bootloader	Feature/Peripheral	State	Comment
Common to all bootloaders	RCC	HSI enabled	At startup, the system clock frequency is configured to 48 MHz using the HSI. If an external clock (HSE) is not present, the system is kept clocked from the HSI.
		HSE enabled	The external clock can be used for all bootloader interfaces and must have one of the following values [24, 18, 16, 12, 8, 6, 4] MHz. The PLL is used to generate 48 MHz for USB and system clock.
		-	The Clock Security System (CSS) interrupt is enabled for HSE. Any failure (or removal) of the external clock generates system reset.
	RAM	-	6 Kbyte starting from address 0x20000000 are used by the bootloader firmware
	System memory	-	13 Kbyte starting from address 0x1FFFC400, contain the bootloader firmware.
USART1 bootloader	USART1	Enabled	Once initialized the USART1 configuration is: 8-bit, even parity and 1 Stop bit
	USART1_RX pin	Input	PA10 pin: USART1 in reception mode
	USART1_TX pin	Output	PA9 pin: USART1 in transmission mode
USART2 bootloader	USART2	Enabled	Once initialized the USART2 configuration is: 8-bit, even parity and 1 Stop bit
	USART2_RX pin	Input	PA15 pin: USART2 in reception mode
	USART2_TX pin	Output	PA14 pin: USART2 in transmission mode
USARTx bootloaders	SysTick timer	Enabled	Used to automatically detect the serial baud rate from the host for USARTx bootloaders.
I2C1 bootloader	I2C1	Enabled	The I2C1 configuration is: I2C speed: up to 400 kHz, 7-bit address, slave mode, analog filter ON. Slave 7-bit address: 0b0111110x where x = 0 for write and x = 1 for read)
	I2C1_SCL pin	Input/Output	PB6 pin: clock line is used in open-drain mode.
	I2C1_SDA pin	Input/Output	PB7 pin: data line is used in open-drain mode.

Table 17. STM32F070x6 configuration in system memory boot mode (continued)

Bootloader	Feature/Peripheral	State	Comment
DFU bootloader	USB	Enabled	USB FS configured in forced device mode. USB FS interrupt vector is enabled and used for USB DFU communications.
	USB_DM pin	Input/Output	PA11 pin: USB FS DM line
	USB_DP pin		PA12 pin: USB FS DP line. No external pull-up resistor is required.

Note: If HSI deviation exceeds 1% the bootloader might not function correctly.

Note: After the STM32F070x6 devices have booted in bootloader mode using USART2, the serial wire debug (SWD) communication is no more possible until the system is reset, because SWD uses PA14 pin (SWCLK) which is already used by the bootloader (USART2_RX).

The bootloader has two cases of operation depending on the presence of the external clock (HSE) at bootloader startup:

- If HSE is present and has a value of 24, 18, 16, 12, 8, 6, 4 MHz, the system clock is configured to 48 MHz with HSE as clock source. The DFU interface, USART1, USART2 and I2C1 are functional and can be used to communicate with the bootloader device.
- If HSE is not present, the HSI is kept as default clock source and only USART1, USART2 and I2C1 are functional.

The external clock (HSE) must be kept if it is connected at bootloader startup because it is used as system clock source.

Note: Due to empty check mechanism present on this product, it is not possible to jump from user code to system bootloader. Such jump results in a jump back to user Flash space, but if the first 4 bytes of User Flash (at 0x0800 0000) are empty at the moment of jump (i.e. erase first sector before jump or execute code from SRAM while Flash is empty), then system bootloader is executed when jumped to.

9.2 Bootloader selection

Figure 12 shows the bootloader selection mechanism.

Figure 12. Bootloader selection for STM32F070x6

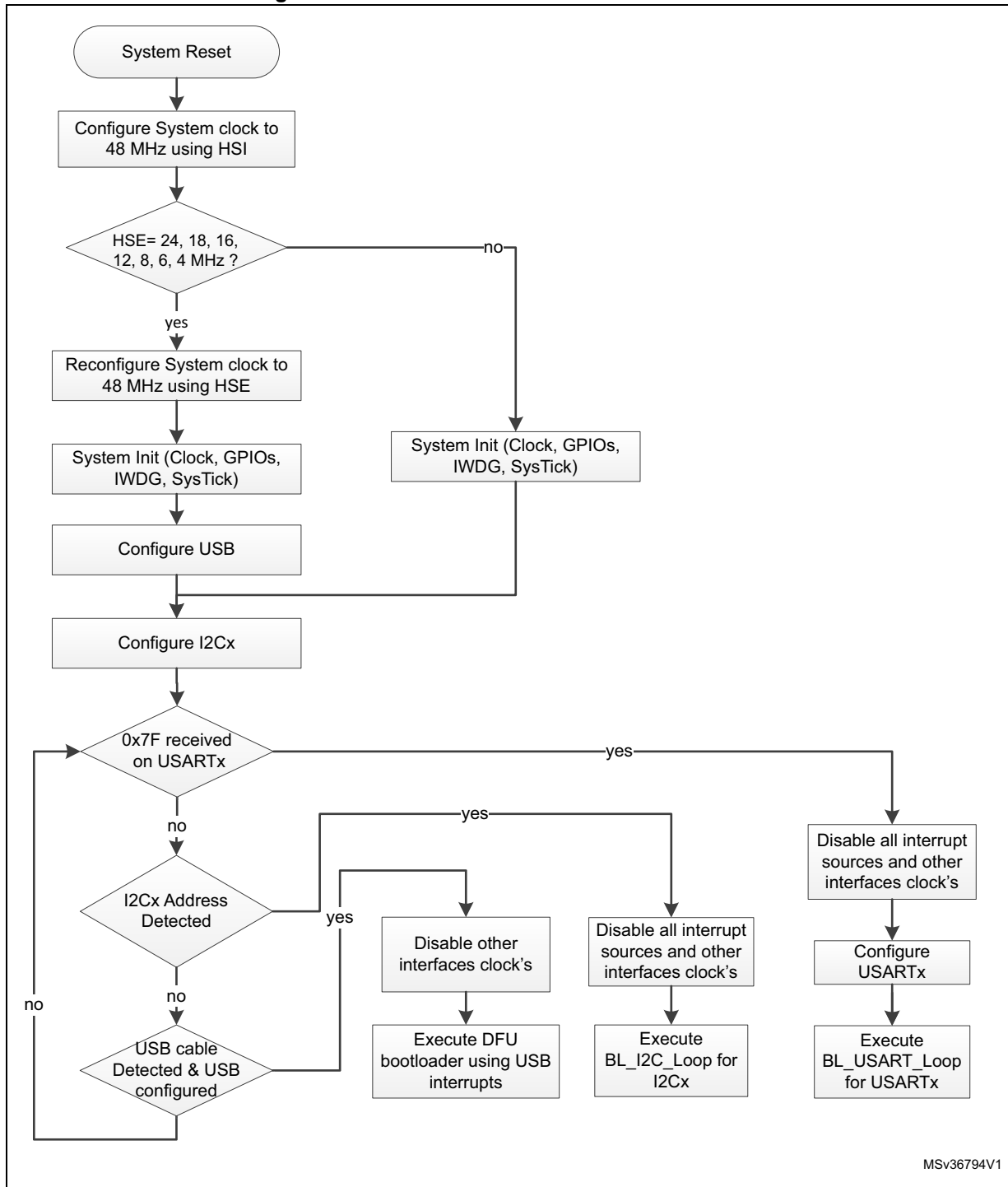

MSv36794V1

9.3 Bootloader version

[Table 18](#) lists the STM32F070x6 devices bootloader versions.

Table 18. STM32F070x6 bootloader versions

Bootloader version number	Description	Known limitations
V10.2	Initial bootloader version	At bootloader startup, the HSITRIM value is set to 0 (in HSITRIM bits on RCC_CR register) instead of default value (16), as a consequence a deviation is generated in crystal measurement. For better results, use the smallest supported crystal value (i.e. 4 MHz).
V10.3	Clock configuration fixed to HSI 8 MHz	

10 STM32F070xB devices bootloader

10.1 Bootloader configuration

The STM32F070xB bootloader is activated by applying Pattern 2 (described in [Table 2: Bootloader activation patterns](#)). [Table 19](#) shows the hardware resources used by this bootloader.

Table 19. STM32F070xB configuration in system memory boot mode

Bootloader	Feature/Peripheral	State	Comment
Common to all bootloaders	RCC	HSI enabled	At startup, the system clock frequency is configured to 48 MHz using the HSI. If an external clock (HSE) is not present, the system is kept clocked from the HSI.
		HSE enabled	The external clock can be used for all bootloader interfaces and must have one of the following values [24, 18, 16, 12, 8, 6, 4] MHz. The PLL is used to generate 48 MHz for USB and system clock.
		-	The Clock Security System (CSS) interrupt is enabled for HSE. Any failure (or removal) of the external clock generates system reset.
	RAM	-	6 Kbyte starting from address 0x20000000 are used by the bootloader firmware
	System memory	-	12 Kbyte starting from address 0x1FFFC800, contain the bootloader firmware.
USART1 bootloader	USART1	Enabled	Once initialized the USART1 configuration is: 8-bit, even parity and 1 Stop bit
	USART1_RX pin	Input	PA10 pin: USART1 in reception mode
	USART1_TX pin	Output	PA9 pin: USART1 in transmission mode
USART2 bootloader	USART2	Enabled	Once initialized the USART2 configuration is: 8-bit, even parity and 1 Stop bit
	USART2_RX pin	Input	PA15 pin: USART2 in reception mode
	USART2_TX pin	Output	PA14 pin: USART2 in transmission mode
USARTx bootloaders	SysTick timer	Enabled	Used to automatically detect the serial baud rate from the host for USARTx bootloaders.
I2C1 bootloader	I2C1	Enabled	The I2C1 configuration is: I2C speed: up to 400 kHz, 7-bit address, slave mode, analog filter ON. Slave 7-bit address: 0b0111011x (where x = 0 for write and x = 1 for read)
	I2C1_SCL pin	Input/Output	PB6 pin: clock line is used in open-drain mode.
	I2C1_SDA pin	Input/Output	PB7 pin: data line is used in open-drain mode.

Table 19. STM32F070xB configuration in system memory boot mode (continued)

Bootloader	Feature/Peripheral	State	Comment
DFU bootloader	USB	Enabled	USB FS configured in forced device mode. USB FS interrupt vector is enabled and used for USB DFU communications.
	USB_DM pin	Input/Output	PA11 pin: USB FS DM line
	USB_DP pin		PA12 pin: USB FS DP line. No external pull-up resistor is required.

Note: If HSI deviation exceeds 1% the bootloader might not function correctly.

Note: After the STM32F070xB devices have booted in bootloader mode using USART2, the serial wire debug (SWD) communication is no more possible until the system is reset, because SWD uses PA14 pin (SWCLK) which is already used by the bootloader (USART2_RX).

The bootloader has two cases of operation depending on the presence of the external clock (HSE) at bootloader startup:

- If HSE is present and has a value of 24, 18, 16, 12, 8, 6, 4 MHz, the system clock is configured to 48 MHz with HSE as clock source. The DFU interface, USART1, USART2 and I2C1 are functional and can be used to communicate with the bootloader device.
- If HSE is not present, the HSI is kept as default clock source and only USART1, USART2 and I2C1 are functional.

The external clock (HSE) must be kept if it is connected at bootloader startup because it is used as system clock source.

10.2 Bootloader selection

Figure 13 shows the bootloader selection mechanism.

Figure 13.Bootloader selection for STM32F070xB

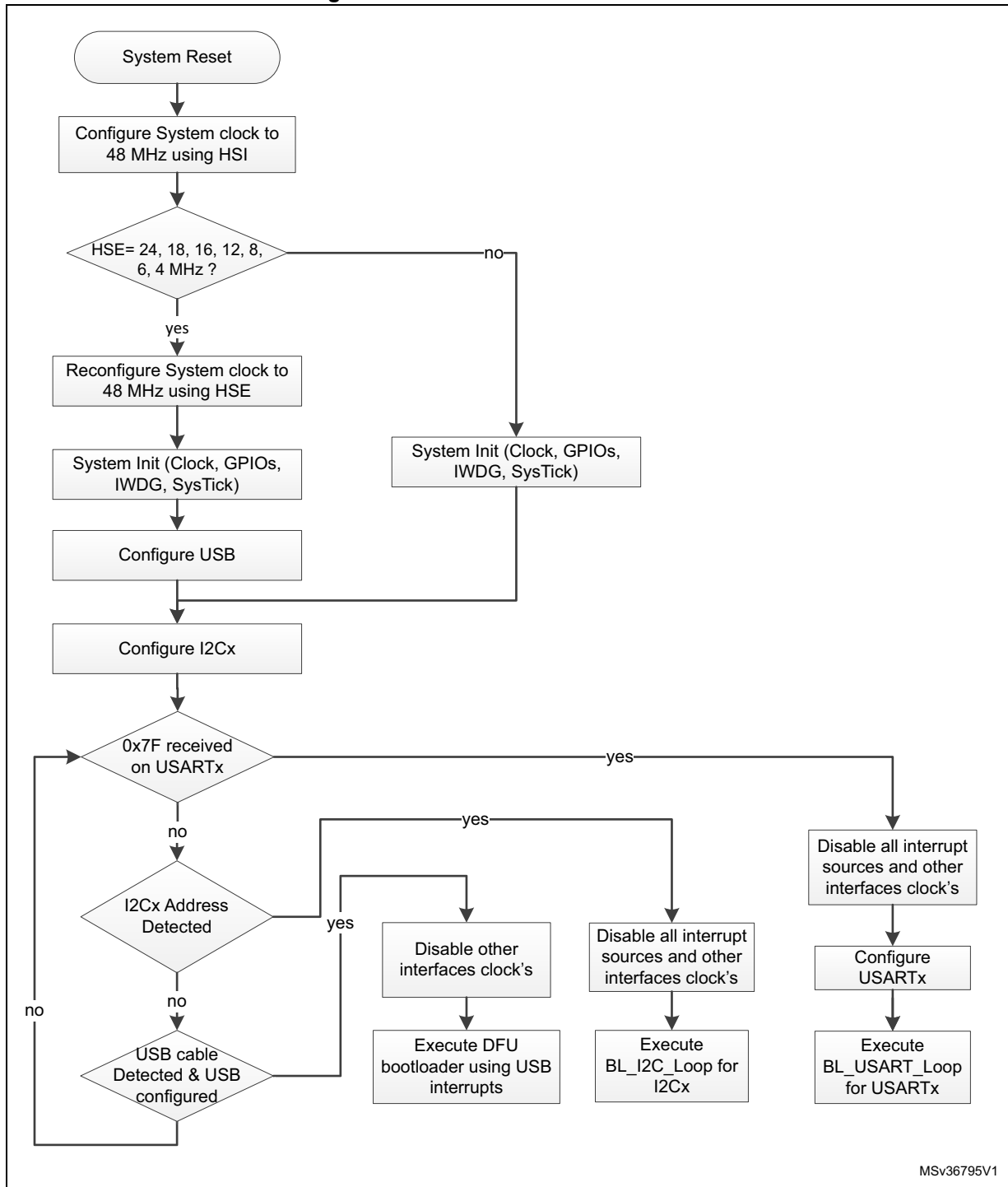

10.3 Bootloader version

[Table 20](#) lists the STM32F070xB devices bootloader versions.

Table 20. STM32F070xB bootloader versions

Bootloader version number	Description	Known limitations
V10.2	Initial bootloader version	At bootloader startup, the HSITRIM value is set to (0) (in HSITRIM bits on RCC_CR register) instead of default value (16), as a consequence a deviation is generated in crystal measurement. For better results, use the smallest supported crystal value (i.e. 4 MHz).
V10.3	Clock configuration fixed to HSI 8 MHz	

11 STM32F071xx/072xx devices bootloader

11.1 Bootloader configuration

The STM32F071xx/072xx bootloader is activated by applying Pattern 2 (described in [Table 2: Bootloader activation patterns](#)). [Table 21](#) shows the hardware resources used by this bootloader.

Table 21. STM32F071xx/072xx configuration in system memory boot mode

Bootloader	Feature/Peripheral	State	Comment
Common to all bootloaders	RCC	HSI enabled	The system clock frequency is 48 MHz with HSI48 48 MHz as clock source.
		-	The clock recovery system (CRS) is enabled for the DFU bootloader to allow USB to be clocked by HSI48 48 MHz.
	RAM	-	6 Kbyte starting from address 0x20000000 are used by the bootloader firmware
	System memory	-	12 Kbyte starting from address 0x1FFFC800, contain the bootloader firmware
	IWDG	-	The independent watchdog (IWDG) prescaler is configured to its maximum value. It is periodically refreshed to prevent watchdog reset (in case the hardware IWDG option was previously enabled by the user).
USART1 bootloader	USART1	Enabled	Once initialized the USART1 configuration is: 8-bit, even parity and 1 Stop bit
	USART1_RX pin	Input	PA10 pin: USART1 in reception mode
	USART1_TX pin	Output	PA9 pin: USART1 in transmission mode
USART2 bootloader	USART2	Enabled	Once initialized the USART2 configuration is: 8-bit, even parity and 1 Stop bit
	USART2_RX pin	Input	PA15 pin: USART2 in reception mode
	USART2_TX pin	Output	PA14 pin: USART2 in transmission mode
USARTx bootloaders	SysTick timer	Enabled	Used to automatically detect the serial baud rate from the host for USARTx bootloaders.
I2C1 bootloader	I2C1	Enabled	The I2C1 configuration is: I2C speed: up to 400 kHz, 7-bit address, slave mode, analog filter ON. Slave 7-bit address: 0b0111011x (where x = 0 for write and x = 1 for read)
	I2C1_SCL pin	Input/Output	PB6 pin: clock line is used in open-drain mode.
	I2C1_SDA pin	Input/Output	PB7 pin: data line is used in open-drain mode.

Table 21. STM32F071xx/072xx configuration in system memory boot mode (continued)

Bootloader	Feature/Peripheral	State	Comment
DFU bootloader	USB	Enabled	USB used in FS mode
	USB_DM pin	Input/Output	PA11: USB DM line.
	USB_DP pin		PA12: USB DP line No external pull-up resistor is required.

Note: After the STM32F071xx/072xx devices have booted in bootloader mode using USART2, the serial wire debug (SWD) communication is no more possible until the system is reset, because SWD uses PA14 pin (SWCLK) which is already used by the bootloader (USART2_RX).

The system clock is derived from the embedded internal high-speed RC, no external quartz is required for the bootloader execution.

11.2 Bootloader selection

Figure 14 shows the bootloader selection mechanism.

Figure 14. Bootloader selection for STM32F071xx/072xx

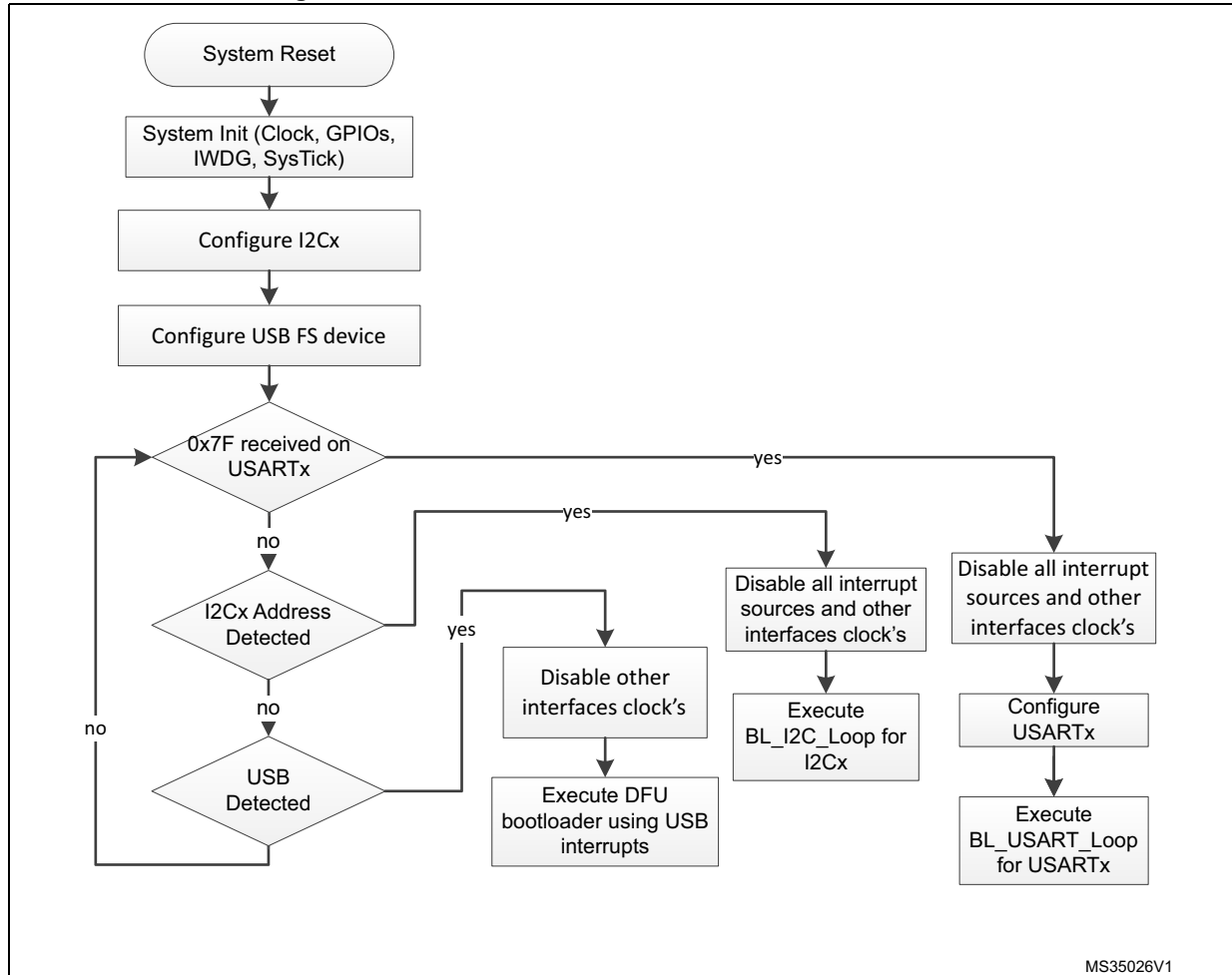

11.3 Bootloader version

Table 22 lists the STM32F071xx/072xx devices bootloader versions.

Table 22. STM32F071xx/072xx bootloader versions

Bootloader version number	Description	Known limitations
V10.1	Initial bootloader version	At bootloader startup, the HSITRIM value is set to (0) (in HSITRIM bits on RCC_CR register) instead of default value (16), as a consequence a deviation is generated in crystal measurement. For better results, use the smallest supported crystal value (i.e. 4 MHz).

12 STM32F09xxx devices bootloader

12.1 Bootloader configuration

The STM32F09xxx bootloader is activated by applying Pattern 6 (described in [Table 2: Bootloader activation patterns](#)). The following table shows the hardware resources used by this bootloader.

Table 23. STM32F09xxx configuration in system memory boot mode

Bootloader	Feature/Peripheral	State	Comment
Common to all bootloaders	RCC	HSI enabled	The system clock frequency is 48 MHz with HSI48 48 MHz as clock source.
	RAM	-	6 Kbyte starting from address 0x20000000 are used by the bootloader firmware
	System memory	-	8 Kbyte starting from address 0x1FFFD800, contain the bootloader firmware.
USART1 bootloader	USART1	Enabled	Once initialized the USART1 configuration is: 8-bit, even parity and 1 Stop bit
	USART1_RX pin	Input	PA10 pin: USART1 in reception mode
	USART1_TX pin	Output	PA9 pin: USART1 in transmission mode
USART2 bootloader	USART2	Enabled	Once initialized the USART2 configuration is: 8-bit, even parity and 1 Stop bit
	USART2_RX pin	Input	PA3 pin: USART2 in reception mode
			PA15 pin: USART2 in reception mode
	USART2_TX pin	Output	PA2 pin: USART2 in transmission mode
PA14 pin: USART2 in transmission mode			
USARTx bootloaders	SysTick timer	Enabled	Used to automatically detect the serial baud rate from the host for USARTx bootloaders.
I2C1 bootloader	I2C1	Enabled	The I2C1 configuration is: I2C speed: up to 400 kHz, 7-bit address, slave mode, analog filter ON. Slave 7-bit address: 0b1000001x (where x = 0 for write and x = 1 for read)
	I2C1_SCL pin	Input/Output	PB6 pin: clock line is used in open-drain mode.
	I2C1_SDA pin	Input/Output	PB7 pin: data line is used in open-drain mode.

Note: After the STM32F09xxx devices have booted in bootloader mode using USART2, the serial wire debug (SWD) communication is no more possible until the system is reset, because SWD uses PA14 pin (SWCLK) which is already used by the bootloader (USART2_RX).

The system clock is derived from the embedded internal high-speed RC, no external quartz is required for the bootloader execution.

12.2 Bootloader selection

The figure below shows the bootloader selection mechanism.

Figure 15. Bootloader selection for STM32F09xxx

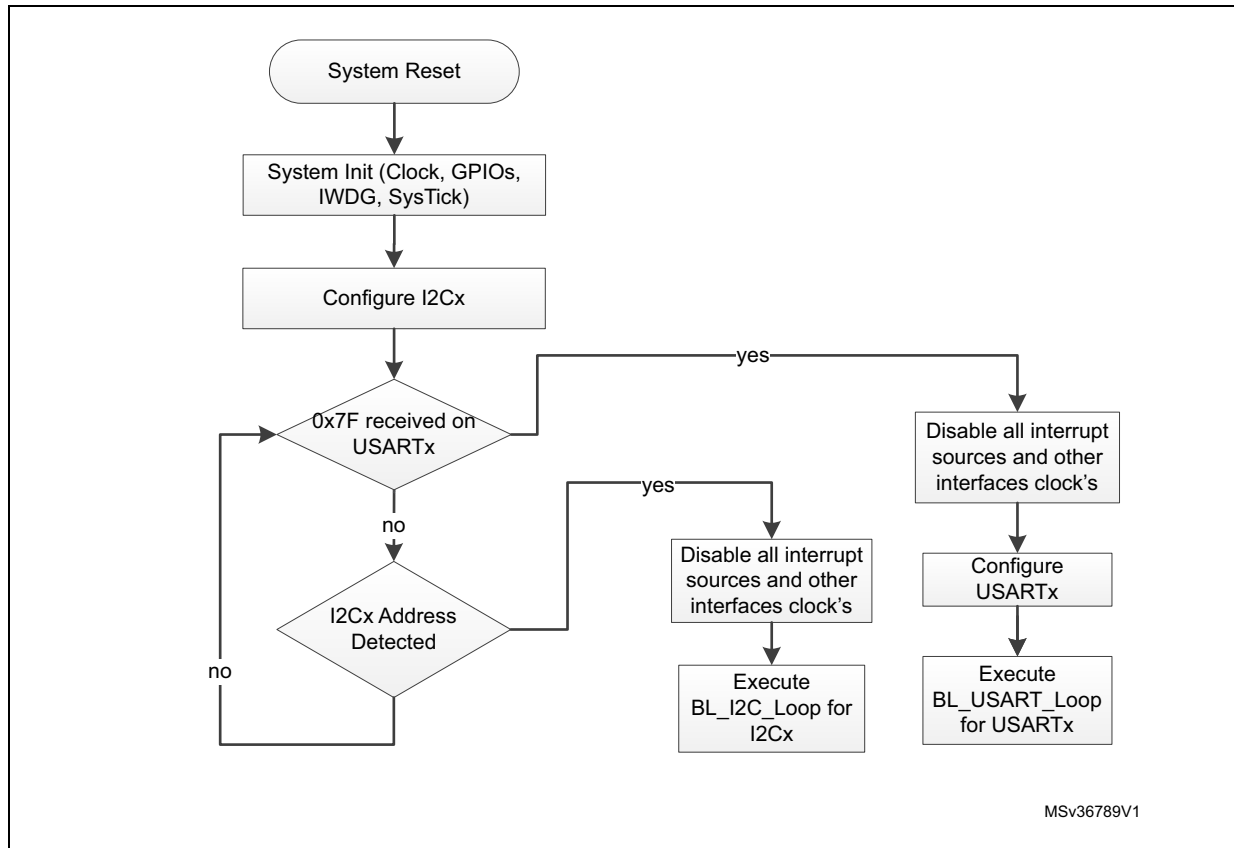

12.3 Bootloader version

The following table lists the STM32F09xxx devices bootloader versions.

Table 24. STM32F09xxx bootloader versions

Bootloader version number	Description	Known limitations
V5.0	Initial bootloader version	At bootloader startup, the HSITRIM value is set to (0) (in HSITRIM bits on RCC_CR register) instead of default value (16), as a consequence a deviation is generated in crystal measurement. For better results, use the smallest supported crystal value (i.e. 4 MHz).

13 STM32F10xxx devices bootloader

13.1 Bootloader configuration

The STM32F10xxx bootloader is activated by applying Pattern 1 (described in [Table 2: Bootloader activation patterns](#)). [Table 25](#) shows the hardware resources used by this bootloader.

Table 25. STM32F10xxx configuration in system memory boot mode

Bootloader	Feature/Peripheral	State	Comment
USART1 bootloader	RCC	HSI enabled	The system clock frequency is 24 MHz using the PLL.
	RAM	-	512 byte starting from address 0x20000000 are used by the bootloader firmware.
	System memory	-	2 Kbyte starting from address 0x1FFFF000 contain the bootloader firmware.
	IWDG	-	The independent watchdog (IWDG) prescaler is configured to its maximum value and is periodically refreshed to prevent watchdog reset (in case the hardware IWDG option was previously enabled by the user).
	USART1	Enabled	Once initialized, the USART1 configuration is: 8 bits, even parity and 1 Stop bit.
	USART1_RX pin	Input	PA10 pin: USART1 in reception mode
	USART1_TX pin	Output push-pull	PA9 pin: USART1 in transmission mode
	SysTick timer	Enabled	Used to automatically detect the serial baud rate from the host.

The system clock is derived from the embedded internal high-speed RC, no external quartz is required for the bootloader execution.

13.2 Bootloader selection

The figure below shows the bootloader selection mechanism.

Figure 16. Bootloader selection for STM32F10xxx

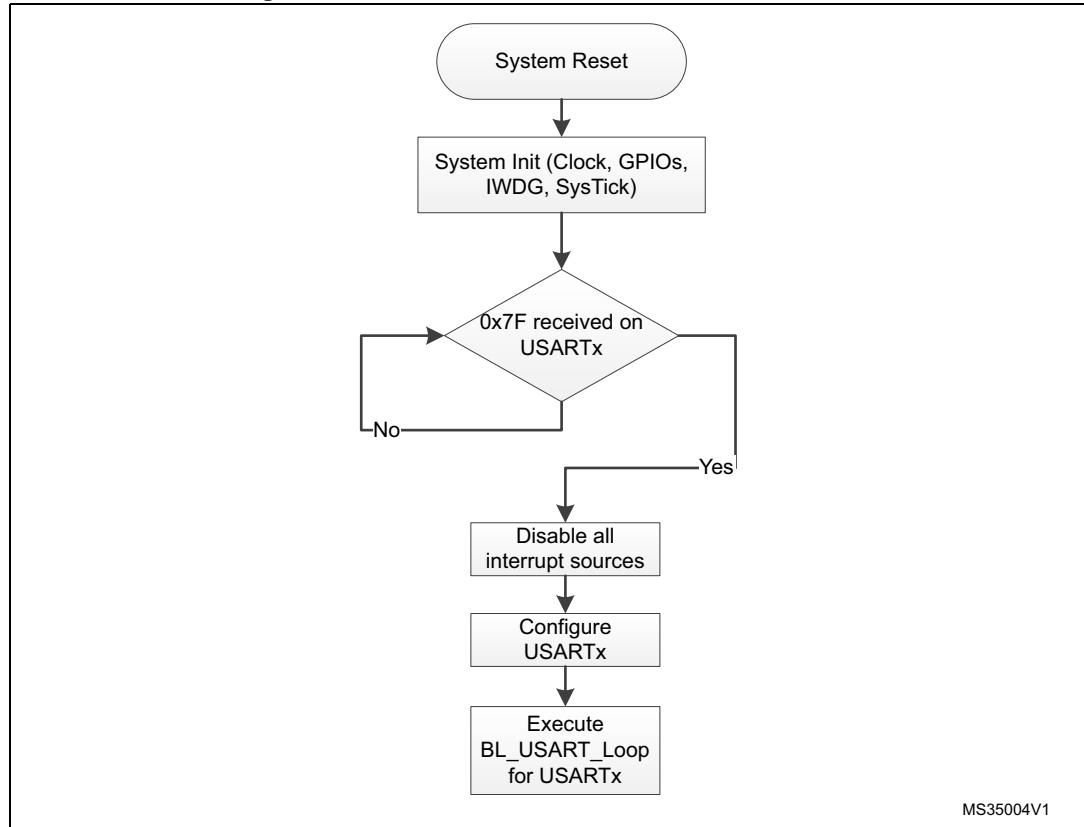

13.3 Bootloader version

Table 26 lists the STM32F10xxx devices bootloader versions:

Table 26. STM32F10xxx bootloader versions

Bootloader version number	Description
V2.0	Initial bootloader version
V2.1	<ul style="list-style-type: none"> – Updated Go Command to initialize the main stack pointer – Updated Go command to return NACK when jump address is in the Option byte area or System memory area – Updated Get ID command to return the device ID on two bytes – Update the bootloader version to V2.1
V2.2	<ul style="list-style-type: none"> – Updated Read Memory, Write Memory and Go commands to deny access with a NACK response to the first 0x200 bytes of RAM memory used by the bootloader – Updated Readout Unprotect command to initialize the whole RAM content to 0x0 before ROP disable operation

Note: The bootloader ID format is applied to all STM32 devices families except the STM32F1xx family. The bootloader version for the STM32F1xx applies only to the embedded device's bootloader version and not to its supported protocols.

14 STM32F105xx/107xx devices bootloader

14.1 Bootloader configuration

The STM32F105xx/107xx bootloader is activated by applying Pattern 1 (described in [Table 2: Bootloader activation patterns](#)). The following table shows the hardware resources used by this bootloader.

Table 27. STM32F105xx/107xx configuration in system memory boot mode

Bootloader	Feature/Peripheral	State	Comment
Common to all bootloaders	RCC	HSI enabled	The system clock frequency is 24 MHz using the PLL. This is used only for USARTx bootloaders and during CAN2, USB detection for CAN and DFU bootloaders (once CAN or DFU bootloader is selected, the clock source is derived from the external crystal).
		HSE enabled	The external clock is mandatory only for DFU and CAN bootloaders and it must provide one of the following frequencies: 8 MHz, 14.7456 MHz or 25 MHz. For CAN bootloader, the PLL is used only to generate 48 MHz when 14.7456 MHz is used as HSE. For DFU bootloader, the PLL is used to generate a 48 MHz system clock from all supported external clock frequencies.
		-	The Clock Security System (CSS) interrupt is enabled for the CAN and DFU bootloaders. Any failure (or removal) of the external clock will generate system reset.
	RAM	-	4 Kbyte starting from address 0x20000000 are used by the bootloader firmware.
	System memory	-	18 Kbyte starting from address 0x1FFFB000 contain the bootloader firmware.
	IWDG	-	The independent watchdog (IWDG) prescaler is configured to its maximum value and is periodically refreshed to prevent watchdog reset (in case the hardware IWDG option was previously enabled by the user).
USART1 bootloader	USART1	Enabled	Once initialized, the USART1 configuration is: 8 bits, even parity and 1 Stop bit.
	USART1_RX pin	Input	PA10 pin: USART1 in reception mode
	USART1_TX pin	Output push-pull	PA9 pin: USART1 in transmission mode

Table 27. STM32F105xx/107xx configuration in system memory boot mode (continued)

Bootloader	Feature/Peripheral	State	Comment
USART2 bootloader	USART2	Enabled	Once initialized, the USART2 configuration is: 8 bits, even parity and 1 Stop bit. The USART2 uses its remapped pins.
	USART2_RX pin	Input	PD6 pin: USART2 receive (remapped pin)
	USART2_TX pin	Output push-pull	PD5 pin: USART2 transmit (remapped pin)
USARTx bootloaders	SysTick timer	Enabled	Used to automatically detect the serial baud rate from the host for USARTx bootloader.
CAN2 bootloader	CAN2	Enabled	Once initialized, the CAN2 configuration is: Baudrate 125 kbps, 11-bit identifier. Note: CAN1 is clocked during the CAN bootloader execution because CAN1 manages the communication between CAN2 and SRAM.
	CAN2_RX pin	Input	PB5 pin: CAN2 receives (remapped pin).
	CAN2_TX pin	Output push-pull	PB6 pin: CAN2 transmits (remapped pin).
DFU bootloader	USB	Enabled	USB OTG FS configured in forced device mode
	USB_VBUS pin	Input	PA9: Power supply voltage line
	USB_DM pin	Input/Output	PA11 pin: USB_DM line
	USB_DP pin		PA12 pin: USB_DP line. No external pull-up resistor is required

The system clock is derived from the embedded internal high-speed RC for USARTx bootloader. This internal clock is used also for DFU and CAN bootloaders but only for the selection phase. An external clock (8 MHz, 14.7456 MHz or 25 MHz) is required for DFU and CAN bootloader execution after the selection phase.

14.2 Bootloader selection

Figure 17 shows the bootloader selection mechanism.

Figure 17. Bootloader selection for STM32F105xx/107xx devices

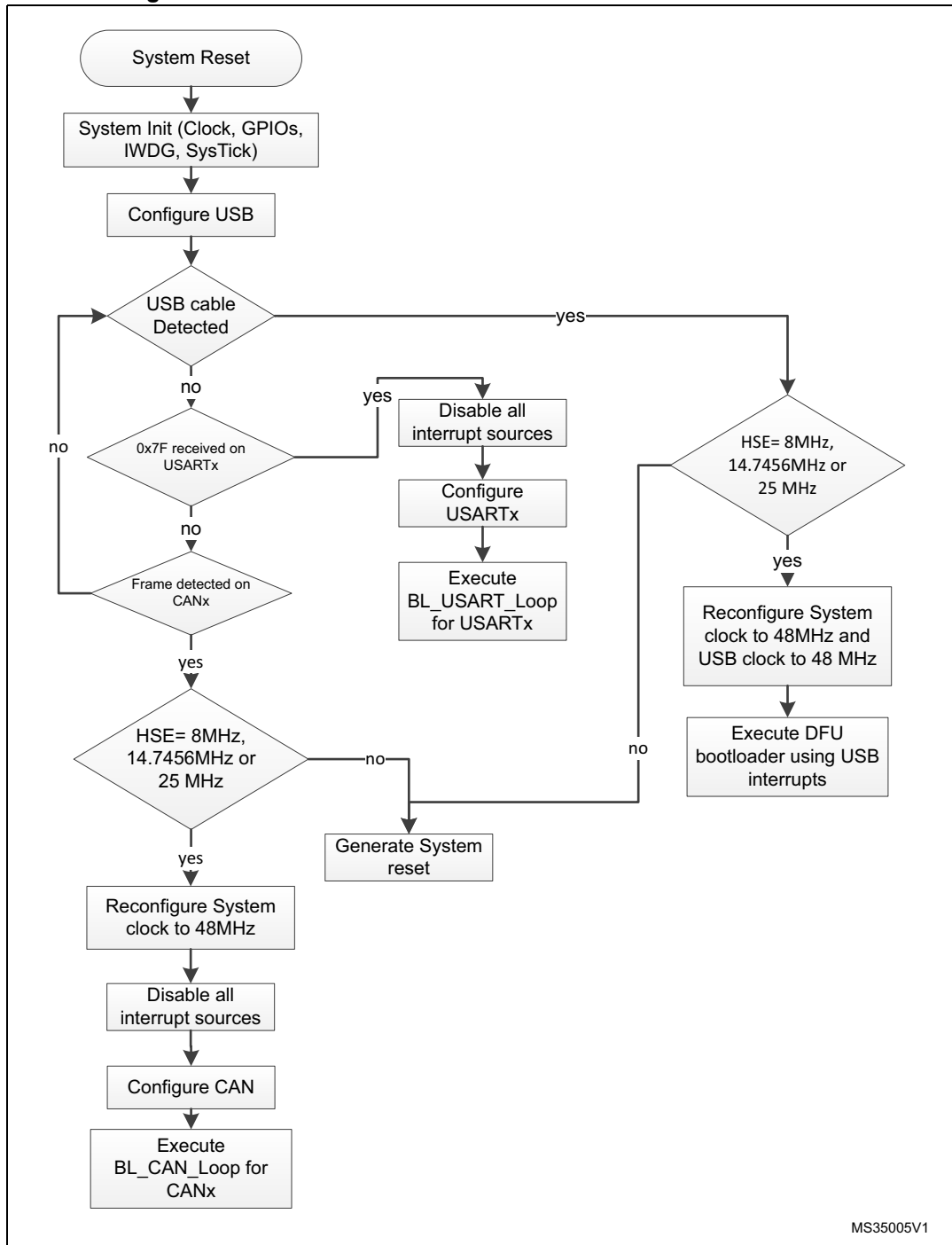

MS35005V1

14.3 Bootloader version

The following table lists the STM32F105xx/107xx devices bootloader versions:

Table 28. STM32F105xx/107xx bootloader versions

Bootloader version number	Description
V1.0	Initial bootloader version
V2.0	<ul style="list-style-type: none"> – Bootloader detection mechanism updated to fix the issue when GPIOs of unused peripherals in this bootloader are connected to low level or left floating during the detection phase. For more details refer to Section 14.3.2. – Vector table set to 0x1FFFB000 instead of 0x00000000 – Go command updated (for all bootloaders): USART1, USART2, CAN2, GPIOA, GPIOB, GPIOD and SysTick peripheral registers are set to their default reset values – DFU bootloader: USB pending interrupt cleared before executing the Leave DFU command – DFU subprotocol version changed from V1.0 to V1.2 – Bootloader version updated to V2.0
V2.1	<ul style="list-style-type: none"> – Fixed PA9 excessive consumption described in Section 14.3.4. – Get-Version command (defined in AN3155) corrected. It returns 0x22 instead of 0x20 in bootloader V2.0. Refer to Section 14.3.3 for more details. – Bootloader version updated to V2.1
V2.2	<ul style="list-style-type: none"> – Fixed DFU option bytes descriptor (set to 'e' instead of 'g' because it is read/write and not erasable). – Fixed DFU polling timings for Flash Read/Write/Erase operations. – Robustness enhancements for DFU bootloader interface. – Updated bootloader version to V2.2.

Note: The bootloader ID format is applied to all STM32 devices families except the STM32F1xx family. The bootloader version for the STM32F1xx applies only to the embedded device's bootloader version and not to its supported protocols.

14.3.1 How to identify STM32F105xx/107xx bootloader versions

Bootloader V1.0 is implemented on devices whose date code is lower than 937 (refer to STM32F105xx and STM32F107xx datasheet to find the date code on the device marking).

Bootloader V2.0 and V2.1 are implemented on devices with a date code higher than or equal to 937.

Bootloader V2.2 is implemented on devices with a date code higher than or equal to 227.

There are two ways to distinguish between bootloader versions:

- When using the USART bootloader, the Get-Version command defined in AN2606 and AN3155 has been corrected in V2.1 version. It returns 0x22 instead of 0x20 as in bootloader V2.0.

- The values of the vector table at the beginning of the bootloader code are different. The user software (or via JTAG/SWD) reads 0x1FFFE945 at address 0x1FFFB004 for bootloader V2.0 0x1FFFE9A1 for bootloader V2.1, and 0x1FFFE9C1 for bootloader V2.2.
- The DFU version is the following:
 - V2.1 in bootloader V2.1
 - V2.2 in bootloader V2.2.It can be read through the `bcdDevice` field of the DFU Device Descriptor.

14.3.2 Bootloader unavailability on STM32F105xx/STM32F107xx devices with date code lower than 937

Description

The bootloader cannot be used if the USART1_RX (PA10), USART2_RX (PD6, remapped), CAN2_Rx (PB5, remapped), OTG_FS_DM (PA11), and/or OTG_FS_DP (PA12) pin(s) are held low or left floating during the bootloader activation phase.

The bootloader cannot be connected through CAN2 (remapped), DFU (OTG FS in Device mode), USART1 or USART2 (remapped).

On 64-pin packages, the USART2_RX signal remapped PD6 pin is not available and it is internally grounded. In this case, the bootloader cannot be used at all.

Workaround

- For 64-pin packages
None. The bootloader cannot be used.
- For 100-pin packages
Depending on the used peripheral, the pins for the unused peripherals have to be kept at a high level during the bootloader activation phase as described below:
 - If USART1 is used to connect to the bootloader, PD6 and PB5 have to be kept at a high level.
 - If USART2 is used to connect to the bootloader, PA10, PB5, PA11 and PA12 have to be kept at a high level.
 - If CAN2 is used to connect to the bootloader, PA10, PD6, PA11 and PA12 have to be kept at a high level.
 - If DFU is used to connect to the bootloader, PA10, PB5 and PD6 have to be kept at a high level.

Note: This limitation applies only to STM32F105xx and STM32F107xx devices with a date code below 937. STM32F105xx and STM32F107xx devices with a date code higher or equal to 937 are not impacted. See STM32F105xx and STM32F107xx datasheets for where to find the date code on the device marking.

14.3.3 USART bootloader Get-Version command returns 0x20 instead of 0x22

Description

In USART mode, the Get-Version command (defined in AN3155) returns 0x20 instead of 0x22.

This limitation is present on bootloader versions V1.0 and V2.0, while it is fixed in bootloader version 2.1.

Workaround

None.

14.3.4 PA9 excessive power consumption when USB cable is plugged in bootloader V2.0

Description

When connecting a USB cable after booting from System-Memory mode, PA9 pin (connected to $V_{BUS}=5\text{ V}$) is also shared with USART TX pin which is configured as alternate push-pull and forced to 0 since the USART peripheral is not yet clocked. As a consequence, a current higher than 25 mA is drained by PA9 I/O and may affect the I/O pad reliability.

This limitation is fixed in bootloader version 2.1 by configuring PA9 as alternate function push-pull when a correct 0x7F is received on RX pin and the USART is clocked. Otherwise, PA9 is configured as alternate input floating.

Workaround

None.

15 STM32F10xxx XL-density devices bootloader

15.1 Bootloader configuration

The STM32F10xxx XL-density bootloader is activated by applying Pattern 3 (described in [Table 2: Bootloader activation patterns](#)). The following table shows the hardware resources used by this bootloader.

Table 29. STM32F10xxx XL-density configuration in system memory boot mode

Bootloader	Feature/Peripheral	State	Comment
Common to all bootloaders	RCC	HSI enabled	The system clock frequency is 24 MHz using the PLL.
	RAM	-	2 Kbyte starting from address 0x20000000 are used by the bootloader firmware.
	System memory	-	6 Kbyte starting from address 0x1FFFE000 contain the bootloader firmware.
	IWDG	-	The independent watchdog (IWDG) prescaler is configured to its maximum value and is periodically refreshed to prevent watchdog reset (in case the hardware IWDG option was previously enabled by the user).
USART1 bootloader	USART1	Enabled	Once initialized, the USART1 configuration is: 8 bits, even parity and 1 Stop bit.
	USART1_RX pin	Input	PA10 pin: USART1 in reception mode
	USART1_TX pin	Output push-pull	PA9 pin: USART1 in transmission mode
USART2 bootloader	USART2	Enabled	Once initialized, the USART2 configuration is: 8 bits, even parity and 1 Stop bit.
	USART2_RX pin	Input	PD6 pin: USART2 receives (remapped pins).
	USART2_TX pin	Output push-pull	PD5 pin: USART2 transmits (remapped pins).
USARTx bootloaders	SysTick timer	Enabled	Used to automatically detect the serial baud rate from the host.

The system clock is derived from the embedded internal high-speed RC, no external quartz is required for the bootloader execution.

15.2 Bootloader selection

Figure 18 shows the bootloader selection mechanism.

Figure 18. Bootloader selection for STM32F10xxx XL-density devices

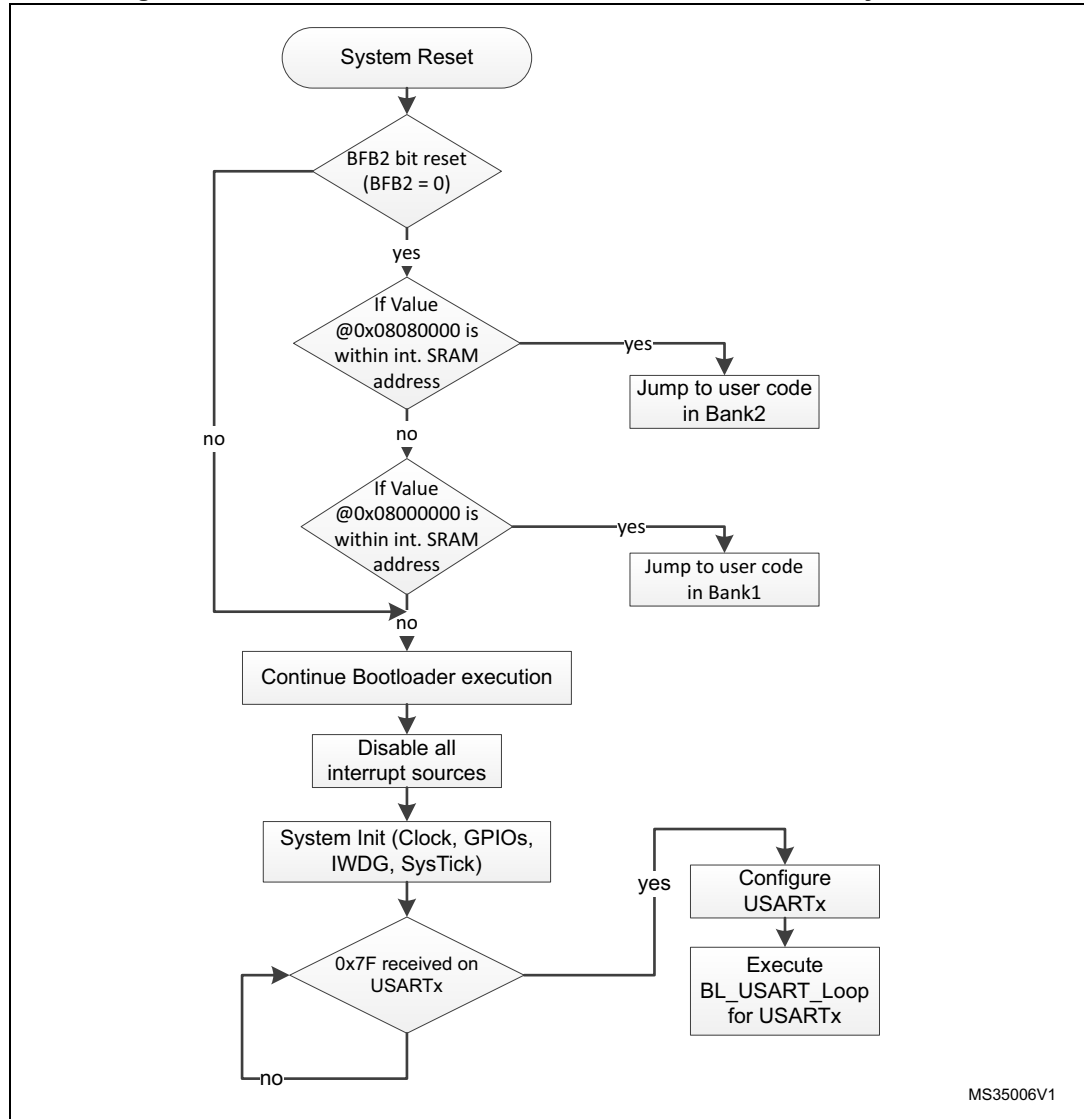

15.3 Bootloader version

Table 30 lists the STM32F10xxx XL-density devices bootloader versions.

Table 30. STM32F10xxx XL-density bootloader versions

Bootloader version number	Description
V2.1	Initial bootloader version

Note: The bootloader ID format is applied to all STM32 devices families except the STM32F1xx family. The bootloader version for the STM32F1xx applies only to the embedded device bootloader version and not to its supported protocols.

16 STM32F2xxxx devices bootloader

Two bootloader versions are available on STM32F2xxxx devices:

- V2.x supporting USART1 and USART3
This version is embedded in revisions A, Z and B
- V3.x supporting USART1, USART3, CAN2 and DFU (USB FS device)
This version is embedded in all other revisions (Y, X, W, 1, V, 2, 3 and 4)

16.1 Bootloader V2.x

16.1.1 Bootloader configuration

The STM32F2xxxx bootloader is activated by applying Pattern 1 (described in [Table 2: Bootloader activation patterns](#)). The following table shows the hardware resources used by this bootloader.

Table 31. STM32F2xxxx configuration in system memory boot mode

Bootloader	Feature/Peripheral	State	Comment
Common to all bootloaders	RCC	HSI enabled	The system clock frequency is 24 MHz.
	RAM	-	8 Kbyte starting from address 0x20000000.
	System memory	-	29 Kbyte starting from address 0x1FFF0000, contain the bootloader firmware.
	IWDG	-	The independent watchdog (IWDG) prescaler is configured to its maximum value and is periodically refreshed to prevent watchdog reset (in case the hardware IWDG option was previously enabled by the user).
	Power	-	Voltage range is set to [1.62 V, 2.1 V]. In this range internal Flash write operations are allowed only in byte format (Half-Word, Word and Double-Word operations are not allowed). The voltage range can be configured in run time using bootloader commands.
USART1 bootloader	USART1	Enabled	Once initialized, the USART1 configuration is: 8 bits, even parity and 1 Stop bit.
	USART1_RX pin	Input	PA10 pin: USART1 in reception mode
	USART1_TX pin	Output	PA9 pin: USART1 in transmission mode
USART3 bootloader (on PC10/PC11)	USART3	Enabled	Once initialized, the USART3 configuration is: 8 bits, even parity and 1 Stop bit.
	USART3_RX pin	Input	PC11 pin: USART3 in reception mode
	USART3_TX pin	Output	PC10 pin: USART3 in transmission mode

Table 31. STM32F2xxxx configuration in system memory boot mode (continued)

Bootloader	Feature/Peripheral	State	Comment
USART3 bootloader (on PB10/PB11)	USART3	Enabled	Once initialized, the USART3 configuration is: 8 bits, even parity and 1 Stop bit
	USART3_RX pin	Input	PB11 pin: USART3 in reception mode
	USART3_TX pin	Output	PB10 pin: USART3 in transmission mode
USARTx bootloaders	SysTick timer	Enabled	Used to automatically detect the serial baud rate from the host.

The system clock is derived from the embedded internal high-speed RC. No external quartz is required for the bootloader code.

16.1.2 Bootloader selection

Figure 19 shows the bootloader selection mechanism.

Figure 19. Bootloader V2.x selection for STM32F2xxxx devices

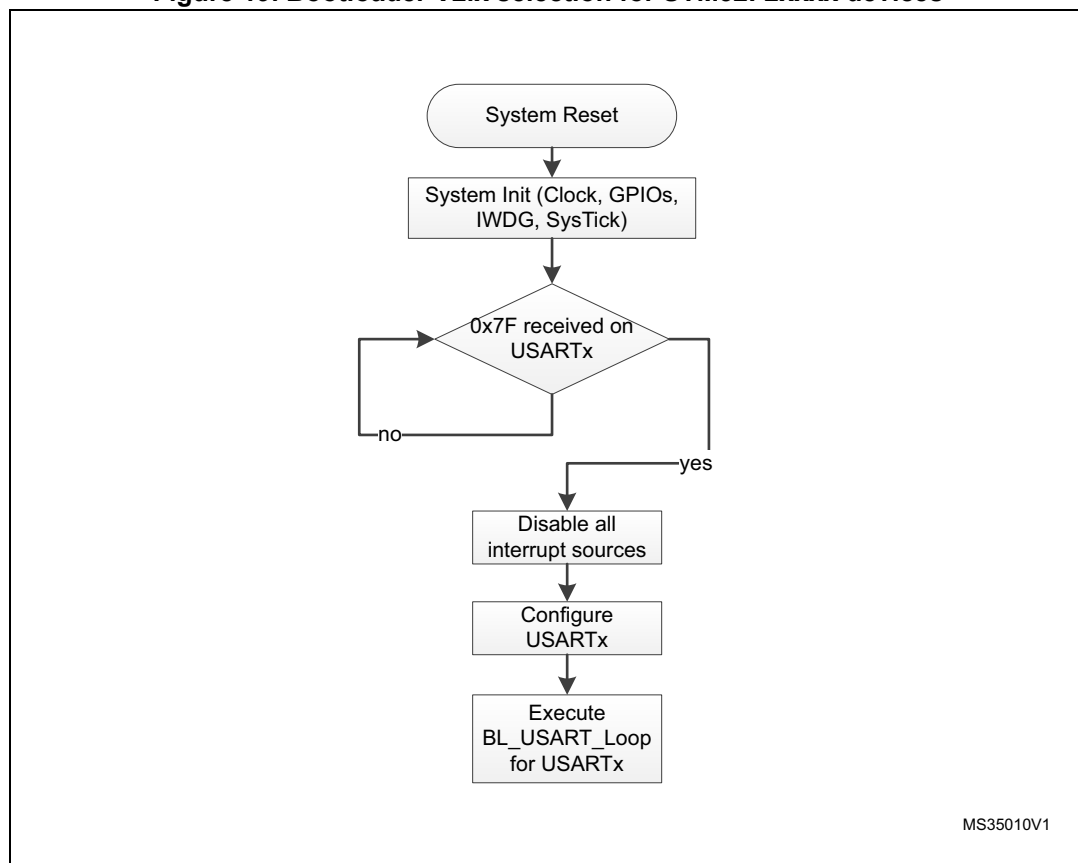

16.1.3 Bootloader version

This following table lists the STM32F2xxxx devices V2.x bootloader versions:

Table 32. STM32F2xxxx bootloader V2.x versions

Bootloader version number	Description	Known limitations
V2.0	Initial bootloader version	<p>When a Read Memory command or Write Memory command is issued with an unsupported memory address and a correct address checksum (i.e. address 0x6000 0000), the command is aborted by the bootloader device, but the NACK (0x1F) is not sent to the host. As a result, the next 2 bytes (which are the number of bytes to be read/written and its checksum) are considered as a new command and its checksum.</p> <p>For the CAN interface, the Write Unprotect command is not functional. Use Write Memory command and write directly to the option bytes in order to disable the write protection.⁽¹⁾</p>

1. If the “number of data - 1” (N-1) to be read/written is not equal to a valid command code (0x00, 0x01, 0x02, 0x11, 0x21, 0x31, 0x43, 0x44, 0x63, 0x73, 0x82 or 0x92), then the limitation is not perceived from the host since the command is NACKed anyway (as an unsupported new command).

16.2 Bootloader V3.x

16.2.1 Bootloader configuration

The STM32F2xxxx bootloader is activated by applying Pattern 1 (described in [Table 2: Bootloader activation patterns](#)). The following table shows the hardware resources used by this bootloader.

Table 33. STM32F2xxxx configuration in system memory boot mode

Bootloader	Feature/Peripheral	State	Comment
Common to all bootloaders	RCC	HSI enabled	The system clock frequency is 24 MHz using the PLL. The HSI clock source is used at startup (interface detection phase) and when USARTx interfaces are selected (once CAN or DFU bootloader is selected, the clock source is derived from the external crystal).
		HSE enabled	The system clock frequency is 60 MHz. The HSE clock source is used only when the CAN or the DFU (USB FS Device) interfaces are selected. The external clock must provide a frequency multiple of 1 MHz and ranging from 4 MHz to 26 MHz.
		-	The Clock Security System (CSS) interrupt is enabled for the CAN and DFU bootloaders. Any failure (or removal) of the external clock generates system reset.
	RAM	-	8 Kbyte starting from address 0x20000000 are used by the bootloader firmware.
	System memory	-	29 Kbyte starting from address 0x1FF00000 contain the bootloader firmware.
	IWDG	-	The independent watchdog (IWDG) prescaler is configured to its maximum value. It is periodically refreshed to prevent watchdog reset (in case the hardware IWDG option was previously enabled by the user).
	Power	-	Voltage range is set to [1.62 V, 2.1 V]. In this range internal Flash write operations are allowed only in byte format (Half-Word, Word and Double-Word operations are not allowed). The voltage range can be configured in run time using bootloader commands.

Table 33. STM32F2xxxx configuration in system memory boot mode (continued)

Bootloader	Feature/Peripheral	State	Comment
USART1 bootloader	USART1	Enabled	Once initialized, the USART1 configuration is: 8 bits, even parity and 1 Stop bit.
	USART1_RX pin	Input	PA10 pin: USART1 in reception mode
	USART1_TX pin	Output	PA9 pin: USART1 in transmission mode
USART3 bootloader (on PB10/PB11)	USART3	Enabled	Once initialized, the USART3 configuration is: 8 bits, even parity and 1 Stop bit.
	USART3_RX pin	Input	PB11 pin: USART3 in reception mode
	USART3_TX pin	Output	PB10 pin: USART3 in transmission mode
USART3 bootloader (on PC10/PC11)	USART3	Enabled	Once initialized, the USART3 configuration is: 8 bits, even parity and 1 Stop bit.
	USART3_RX pin	Input	PC11 pin: USART3 in reception mode
	USART3_TX pin	Output	PC10 pin: USART3 in transmission mode
USARTx bootloaders	SysTick timer	Enabled	Used to automatically detect the serial baud rate from the host for USARTx bootloaders.
CAN2 bootloader	CAN2	Enabled	Once initialized, the CAN2 configuration is: Baudrate 125 kbps, 11-bit identifier. Note: CAN1 is clocked during CAN2 bootloader execution because CAN1 manages the communication between CAN2 and SRAM.
	CAN2_RX pin	Input	PB5 pin: CAN2 in reception mode
	CAN2_TX pin	Output	PB13 pin: CAN2 in transmission mode
DFU bootloader	USB	Enabled	USB OTG FS configured in forced device mode
	USB_DM pin	Input/Output	PA11: USB DM line.
	USB_DP pin		PA12: USB DP line No external pull-up resistor is required
CAN2 and DFU bootloaders	TIM11	Enabled	This timer is used to determine the value of the HSE. Once the HSE frequency is determined, the system clock is configured to 60 MHz using PLL and HSE.

The system clock is derived from the embedded internal high-speed RC for USARTx bootloaders. This internal clock is also used for CAN and DFU (USB FS Device) but only for the selection phase. An external clock multiple of 1 MHz (between 4 and 26 MHz) is required for CAN and DFU bootloader execution after the selection phase.

16.2.2 Bootloader selection

The figure below shows the bootloader selection mechanism.

Figure 20. Bootloader V3.x selection for STM32F2xxxx devices

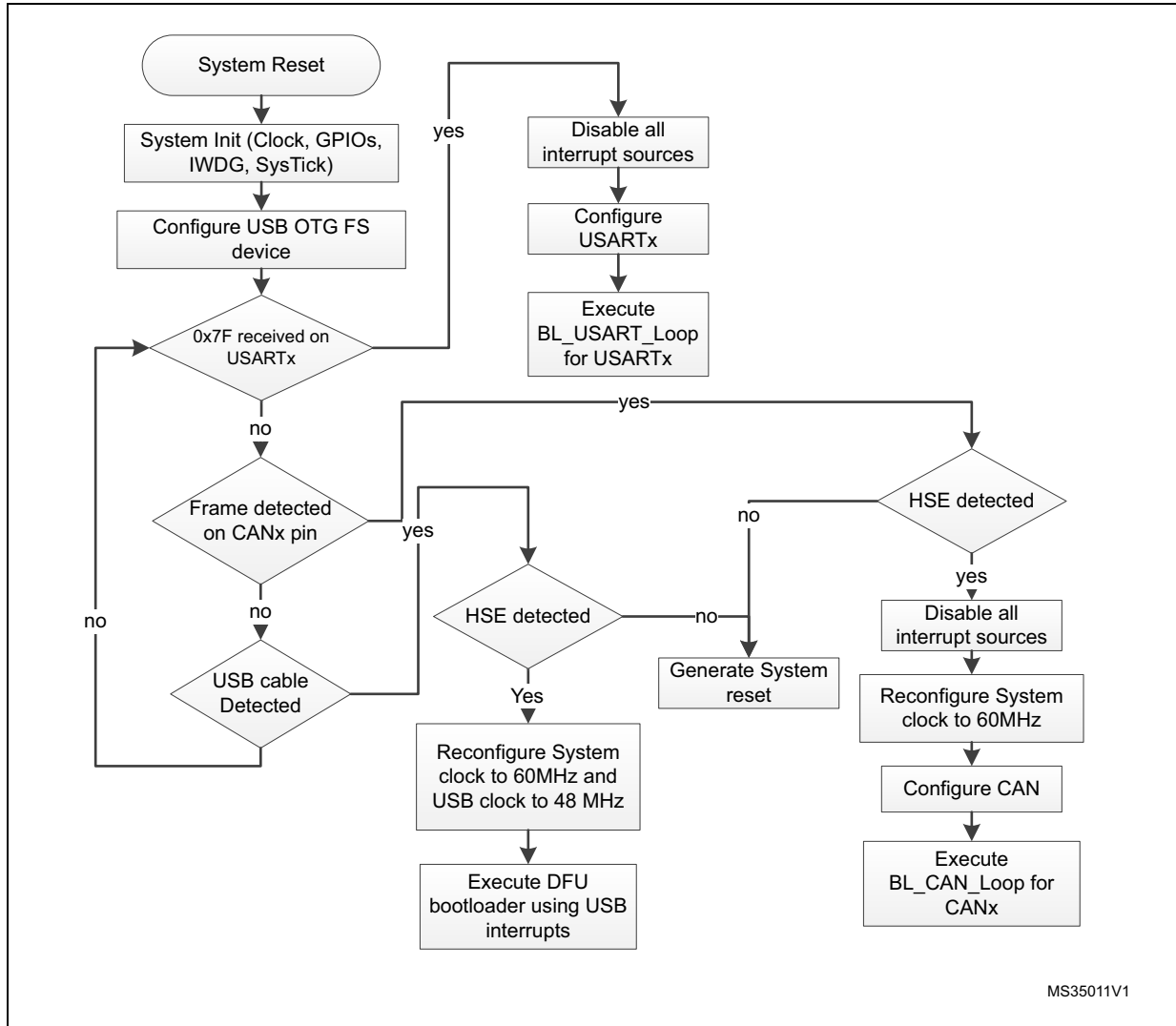

MS35011V1

16.2.3 Bootloader version

The following table lists the STM32F2xxxx devices V3.x bootloader versions:

Table 34. STM32F2xxxx bootloader V3.x versions

Bootloader version number	Description	Known limitations
V3.2	Initial bootloader version.	<ul style="list-style-type: none"> – When a Read Memory command or Write Memory command is issued with an unsupported memory address and a correct address checksum (i.e. address 0x6000 0000), the command is aborted by the bootloader device, but the NACK (0x1F) is not sent to the host. As a result, the next 2 bytes (which are the number of bytes to be read/written and its checksum) are considered as a new command and its checksum⁽¹⁾. – Option bytes, OTP and Device Feature descriptors (in DFU interface) are set to “g” instead of “e” (not erasable memory areas).
V3.3	Fix V3.2 limitations. DFU interface robustness enhancement.	<ul style="list-style-type: none"> – For the USART interface, two consecutive NACKs (instead of 1 NACK) are sent when a Read Memory or Write Memory command is sent and the RDP level is active. – For the CAN interface, the Write Unprotect command is not functional. Use Write Memory command and write directly to the option bytes in order to disable the write protection.

1. If the “number of data - 1” (N-1) to be read/written is not equal to a valid command code (0x00, 0x01, 0x02, 0x11, 0x21, 0x31, 0x43, 0x44, 0x63, 0x73, 0x82 or 0x92), then the limitation is not perceived from the host since the command is NACKed anyway (as an unsupported new command).

17 STM32F301xx/302x4(6/8) devices bootloader

17.1 Bootloader configuration

The STM32F301xx/302x4(6/8) bootloader is activated by applying Pattern 2 (described in [Table 2: Bootloader activation patterns](#)). The following table shows the hardware resources used by this bootloader.

Table 35. STM32F301xx/302x4(6/8) configuration in system memory boot mode

Bootloader	Feature/Peripheral	State	Comment
Common to all bootloaders	RCC	HSI enabled	The system clock frequency is 48 MHz with HSI48 48 MHz as clock source.
		HSE enabled	The external clock can be used for all bootloader interfaces and must have one the following values [24, 18, 16, 12, 9, 8, 6, 4, 3] MHz. The PLL is used to generate the USB48 MHz clock and the 48 MHz clock for the system clock.
		-	The Clock Security System (CSS) interrupt is enabled for the DFU bootloader. Any failure (or removal) of the external clock generates system reset.
	RAM	-	6 Kbyte starting from address 0x20000000 are used by the bootloader firmware
	System memory	-	8 Kbyte starting from address 0x1FFFD800, contain the bootloader firmware
	IWDG	-	The independent watchdog (IWDG) prescaler is configured to its maximum value. It is periodically refreshed to prevent watchdog reset (in case the hardware IWDG option was previously enabled by the user).
USART1 bootloader	USART1	Enabled	Once initialized the USART1 configuration is: 8-bit, even parity and 1 Stop bit
	USART1_RX pin	Input	PA10 pin: USART1 in reception mode
	USART1_TX pin	Output	PA9 pin: USART1 in transmission mode
USART2 bootloader	USART2	Enabled	Once initialized the USART2 configuration is: 8-bit, even parity and 1 Stop bit
	USART2_RX pin	Input	PA3 pin: USART2 in reception mode
	USART2_TX pin	Output	PA2 pin: USART2 in transmission mode
USARTx bootloaders	SysTick timer	Enabled	Used to automatically detect the serial baud rate from the host for USARTx bootloaders.

Table 35. STM32F301xx/302x4(6/8) configuration in system memory boot mode (continued)

Bootloader	Feature/Peripheral	State	Comment
DFU bootloader	USB	Enabled	USB used in FS mode
	USB_DM pin	Input/Output	PA11: USB DM line.
	USB_DP pin		PA12: USB DP line An external pull-up resistor 1.5 KΩ must be connected to USB_DP pin.

The bootloader has two case of operation depending on the presence of the external clock (HSE) at bootloader startup:

- If HSE is present and has a value of 24, 18, 16, 12, 9, 8, 6, 4 or 3 MHz, the system clock is configured to 48 MHz with HSE as clock source. The DFU interface, USART1 and USART2 are functional and can be used to communicate with the bootloader device.
- If HSE is not present, the HSI is kept as default clock source and only USART1 and USART2 are functional.

The external clock (HSE) must be kept if it is connected at bootloader startup because it is used as system clock source.

17.2 Bootloader selection

Figure 21 shows the bootloader selection mechanism.

Figure 21. Bootloader selection for STM32F301xx/302x4(6/8)

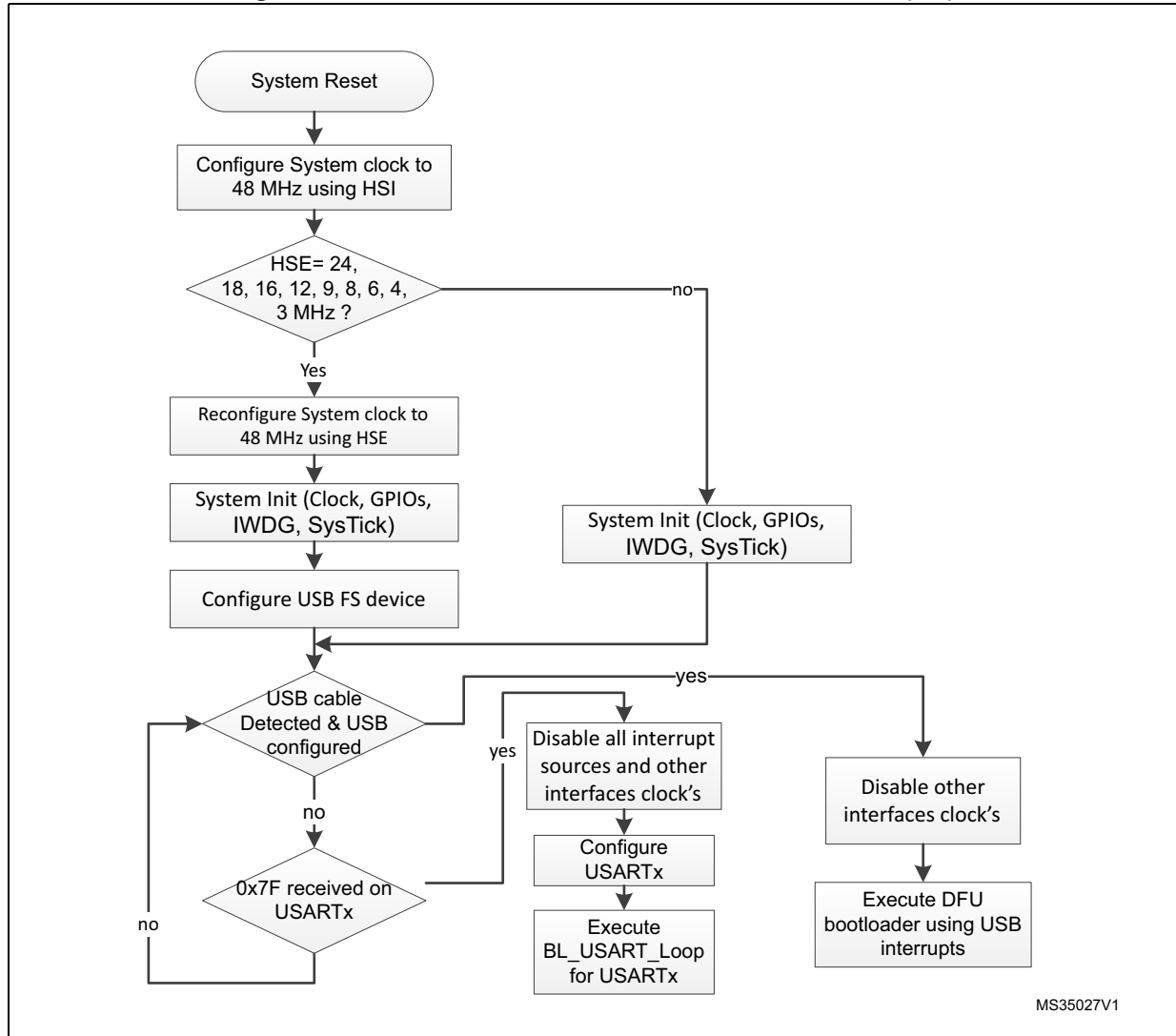

17.3 Bootloader version

The following table lists the STM32F301xx/302x4(6/8) devices bootloader versions:

Table 36. STM32F301xx/302x4(6/8) bootloader versions

Bootloader version number	Description	Known limitations
V4.0	Initial bootloader version	None

18 STM32F302xB(C)/303xB(C) devices bootloader

18.1 Bootloader configuration

The STM32F302xB(C)/303xB(C) bootloader is activated by applying Pattern 2 (described in [Table 2: Bootloader activation patterns](#)). The following table shows the hardware resources used by this bootloader.

Table 37. STM32F302xB(C)/303xB(C) configuration in system memory boot mode

Bootloader	Feature/Peripheral	State	Comment
Common to all bootloaders	RCC	HSI enabled	At startup, the system clock frequency is configured to 48 MHz using the HSI. If an external clock (HSE) is not present, the system is kept clocked from the HSI.
		HSE enabled	The external clock can be used for all bootloader interfaces and must have one the following values [24, 18,16, 12, 9, 8, 6, 4, 3] MHz. The PLL is used to generate the USB 48 MHz clock and the 48 MHz clock for the system clock.
		-	The Clock Security System (CSS) interrupt is enabled for the DFU bootloader. Any failure (or removal) of the external clock generates system reset.
	RAM	-	5 Kbyte starting from address 0x20000000 are used by the bootloader firmware.
	System memory	-	8 Kbyte starting from address 0x1FFFD800, contains the bootloader firmware.
	IWDG	-	The independent watchdog (IWDG) prescaler is configured to its maximum value and is periodically refreshed to prevent watchdog reset (in case the hardware IWDG option was previously enabled by the user).
USART1 bootloader	USART1	Enabled	Once initialized, the USART1 configuration is: 8 bits, even parity and 1 Stop bit.
	USART1_RX pin	Input	PA10 pin: USART1 in reception mode
	USART1_TX pin	Output	PA9 pin: USART1 in transmission mode
USART2 bootloader	USART2	Enabled	Once initialized, the USART2 configuration is: 8 bits, even parity and 1 Stop bit. The USART2 uses its remapped pins.
	USART2_RX pin	Input	PD6 pin: USART2 in reception mode
	USART2_TX pin	Output	PD5 pin: USART2 in transmission mode
USARTx bootloaders	SysTick timer	Enabled	Used to automatically detect the serial baud rate from the host for USARTx bootloader.

Table 37. STM32F302xB(C)/303xB(C) configuration in system memory boot mode (continued)

Bootloader	Feature/Peripheral	State	Comment
DFU bootloader	USB	Enabled	USB used in FS mode
	USB_DM pin	Input/Output	PA11: USB DM line.
	USB_DP pin		PA12: USB DP line An external pull-up resistor 1.5 K Ω must be connected to USB_DP pin.

The bootloader has two case of operation depending on the presence of the external clock (HSE) at bootloader startup:

- If HSE is present and has a value of 24, 18, 16, 12, 9, 8, 6, 4 or 3 MHz, the system clock is configured to 48 MHz with HSE as clock source. The DFU interface, USART1 and USART2 are functional and can be used to communicate with the bootloader device.
- If HSE is not present, the HSI is kept as default clock source and only USART1 and USART2 are functional.

The external clock (HSE) must be kept if it is connected at bootloader startup because it is used as system clock source.

18.2 Bootloader selection

The figure below shows the bootloader selection mechanism.

Figure 22. Bootloader selection for STM32F302xB(C)/303xB(C) devices

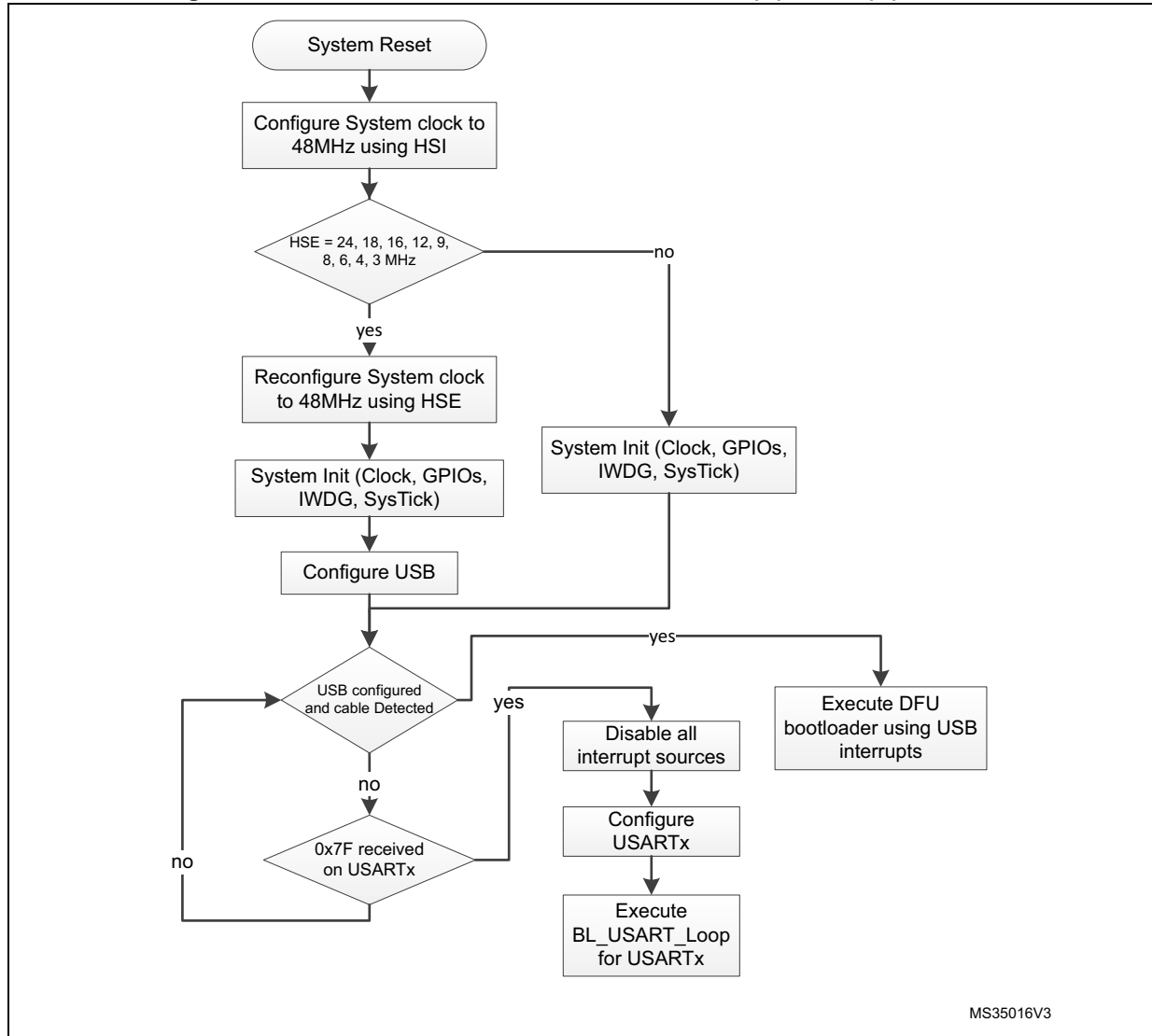

18.3 Bootloader version

The following table lists the STM32F302xB(C)/303xB(C) devices bootloader versions.

Table 38. STM32F302xB(C)/303xB(C) bootloader versions

Bootloader version number	Description	Known limitations
V4.1	Initial bootloader version	None

19 STM32F302xD(E)/303xD(E) devices bootloader

19.1 Bootloader configuration

The STM32F302xD(E)/303xD(E) bootloader is activated by applying Pattern 2 (described in [Table 2: Bootloader activation patterns](#)). The following table shows the hardware resources used by this bootloader.

Table 39. STM32F302xD(E)/303xD(E) configuration in system memory boot mode

Bootloader	Feature/Peripheral	State	Comment
Common to all bootloaders	RCC	HSI enabled	The system clock frequency is 48 MHz with HSI48 48 MHz as clock source.
		HSE enabled	The external clock can be used for all bootloader interfaces and must have one the following values [24, 18, 16, 12, 9, 8, 6, 4, 3] MHz. The PLL is used to generate the USB 48 MHz clock and the 48 MHz clock for the system clock.
		-	The Clock Security System (CSS) interrupt is enabled for the DFU bootloader. Any failure (or removal) of the external clock generates system reset.
	RAM	-	6 Kbyte starting from address 0x20000000 are used by the bootloader firmware
	System memory	-	8 Kbyte starting from address 0x1FFFD800, contain the bootloader firmware
IWDG	-	The independent watchdog (IWDG) prescaler is configured to its maximum value. It is periodically refreshed to prevent watchdog reset (in case the hardware IWDG option was previously enabled by the user).	
USART1 bootloader	USART1	Enabled	Once initialized the USART1 configuration is: 8-bit, even parity and 1 Stop bit
	USART1_RX pin	Input	PA10 pin: USART1 in reception mode
	USART1_TX pin	Output	PA9 pin: USART1 in transmission mode
USART2 bootloader	USART2	Enabled	Once initialized the USART2 configuration is: 8-bit, even parity and 1 Stop bit
	USART2_RX pin	Input	PA3 pin: USART2 in reception mode
	USART2_TX pin	Output	PA2 pin: USART2 in transmission mode
USARTx bootloaders	SysTick timer	Enabled	Used to automatically detect the serial baud rate from the host for USARTx bootloaders.
DFU bootloader	USB	Enabled	USB FS configured in forced device mode. USB FS interrupt vector is enabled and used for USB DFU communications.
	USB_DM pin	Input/Output	PA11 pin: USB FS DM line.
	USB_DP pin		PA12 pin: USB FS DP line. An external pull-up resistor 1.5 KΩ must be connected to USB_DP pin.

The bootloader has two cases of operation depending on the presence of the external clock (HSE) at bootloader startup:

- If HSE is present and has a value of 24, 18, 16, 12, 9, 8, 6, 4 or 3 MHz, the system clock is configured to 48 MHz with HSE as clock source. The DFU interface, USART1 and USART2 are functional and can be used to communicate with the bootloader device.
- If HSE is not present, the HSI is kept as default clock source and only USART1 and USART2 are functional.

The external clock (HSE) must be kept if it is connected at bootloader startup because it is used as system clock source.

19.2 Bootloader selection

The figure below shows the bootloader selection mechanism.

Figure 23. Bootloader selection for STM32F302xD(E)/303xD(E)

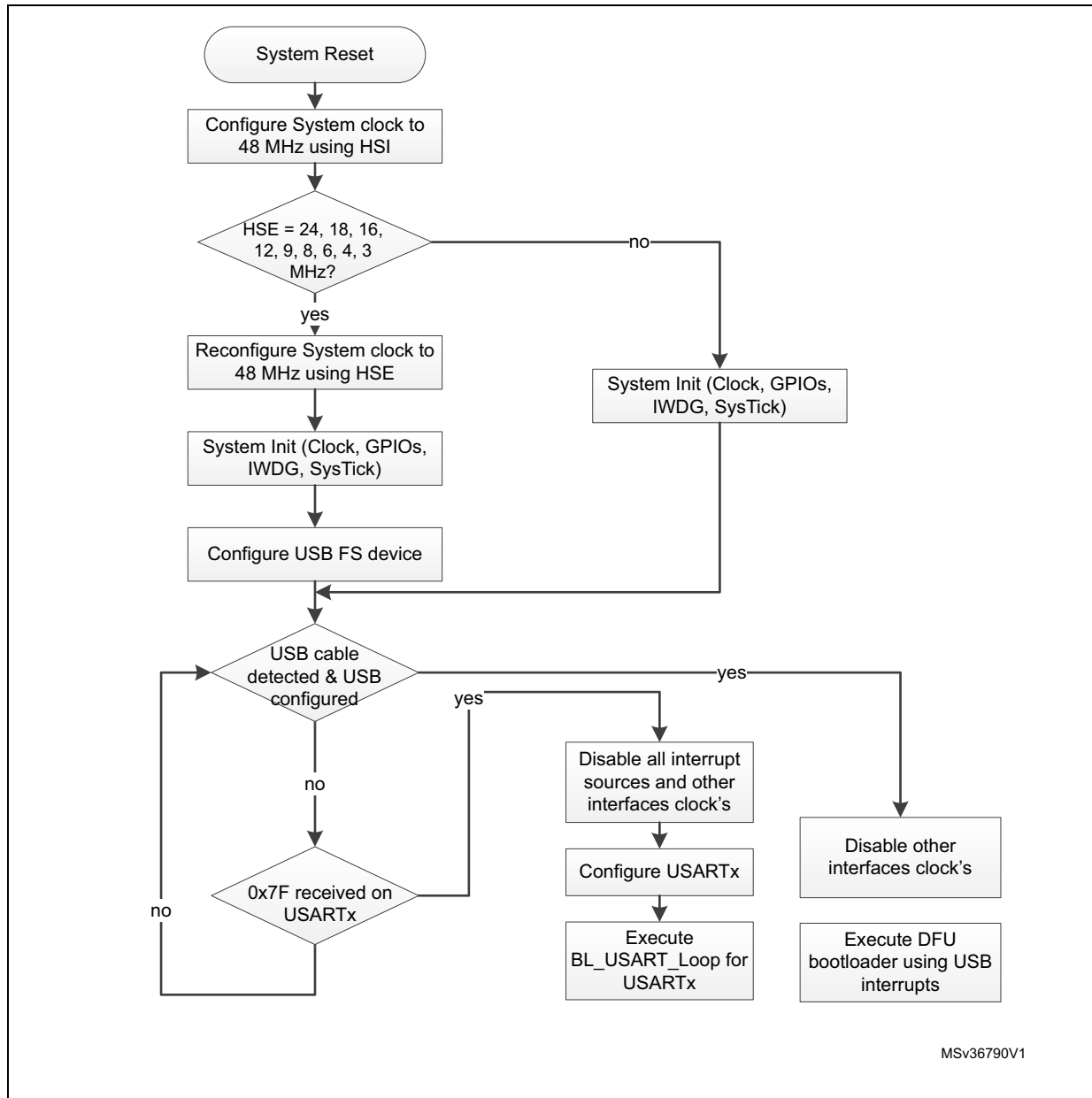

19.3 Bootloader version

The following table lists the STM32F302xD(E)/303xD(E) devices bootloader versions.

Table 40. STM32F302xD(E)/303xD(E) bootloader versions

Bootloader version number	Description	Known limitations
V4.0	Initial bootloader version	None

20 STM32F303x4(6/8)/334xx/328xx devices bootloader

20.1 Bootloader configuration

The STM32F303x4(6/8)/334xx/328xx bootloader is activated by applying Pattern 2 (described in [Table 2: Bootloader activation patterns](#)). The following table shows the hardware resources used by this bootloader.

Table 41. STM32F303x4(6/8)/334xx/328xx configuration in system memory boot mode

Bootloader	Feature/Peripheral	State	Comment
Common to all bootloaders	RCC	HSI enabled	The system clock frequency is 60 MHz with HSI 8 MHz as clock source.
	RAM	-	6 Kbyte starting from address 0x20000000 are used by the bootloader firmware
	System memory	-	8 Kbyte starting from address 0x1FFFD800, contain the bootloader firmware
	IWDG	-	The independent watchdog (IWDG) prescaler is configured to its maximum value. It is periodically refreshed to prevent watchdog reset (in case the hardware IWDG option was previously enabled by the user).
USART1 bootloader	USART1	Enabled	Once initialized the USART1 configuration is: 8-bit, even parity and 1 Stop bit
	USART1_RX pin	Input	PA10 pin: USART1 in reception mode
	USART1_TX pin	Output	PA9 pin: USART1 in transmission mode
USART2 bootloader	USART2	Enabled	Once initialized the USART2 configuration is: 8-bit, even parity and 1 Stop bit
	USART2_RX pin	Input	PA3 pin: USART2 in reception mode
	USART2_TX pin	Output	PA2 pin: USART2 in transmission mode
USARTx bootloaders	SysTick timer	Enabled	Used to automatically detect the serial baud rate from the host for USARTx bootloaders.
I2C1 bootloader	I2C1	Enabled	The I2C1 configuration is: I2C speed: up to 400 kHz, 7-bit address, slave mode, analog filter ON. Slave 7-bit address: 0b0111111x (where x = 0 for write and x = 1 for read)
	I2C1_SCL pin	Input/Output	PB6 pin: clock line is used in open-drain mode.
	I2C1_SDA pin	Input/Output	PB7 pin: data line is used in open-drain mode.

The system clock is derived from the embedded internal high-speed RC, no external quartz is required for the bootloader execution.

20.2 Bootloader selection

The figure below shows the bootloader selection mechanism.

Figure 24. Bootloader selection for STM32F303x4(6/8)/334xx/328xx

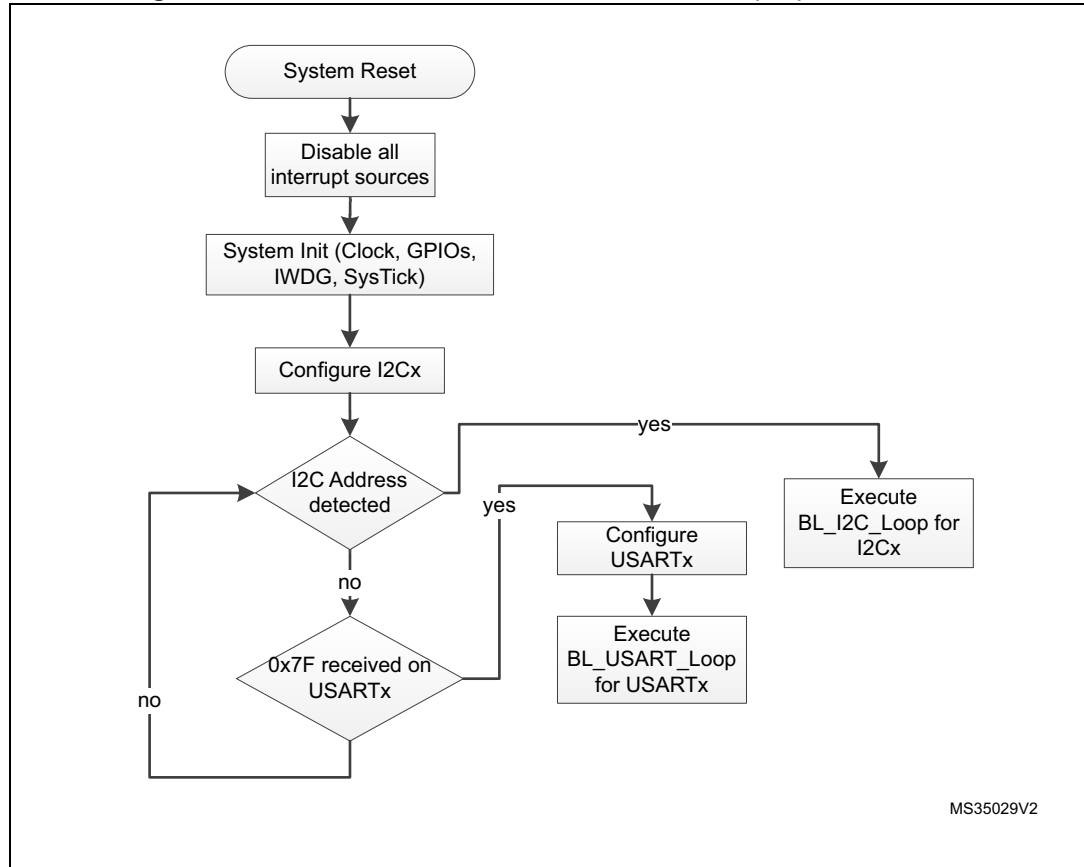

20.3 Bootloader version

The following table lists the STM32F303x4(6/8)/334xx/328xx devices bootloader versions:

Table 42. STM32F303x4(6/8)/334xx/328xx bootloader versions

Bootloader version number	Description	Known limitations
V5.0	Initial bootloader version	None

21 STM32F318xx devices bootloader

21.1 Bootloader configuration

The STM32F318xx bootloader is activated by applying Pattern 2 (described in [Table 2: Bootloader activation patterns](#)). The following table shows the hardware resources used by this bootloader.

Table 43. STM32F318xx configuration in system memory boot mode

Bootloader	Feature/Peripheral	State	Comment
Common to all bootloaders	RCC	HSI enabled	The system clock frequency is 60 MHz with HSI 8 MHz as clock source.
	RAM	-	6 Kbyte starting from address 0x20000000 are used by the bootloader firmware
	System memory	-	8 Kbyte starting from address 0x1FFFD800, contain the bootloader firmware
	IWDG	-	The independent watchdog (IWDG) prescaler is configured to its maximum value. It is periodically refreshed to prevent watchdog reset (in case the hardware IWDG option was previously enabled by the user).
USART1 bootloader	USART1	Enabled	Once initialized the USART1 configuration is: 8-bit, even parity and 1 Stop bit
	USART1_RX pin	Input	PA10 pin: USART1 in reception mode
	USART1_TX pin	Output	PA9 pin: USART1 in transmission mode
USART2 bootloader	USART2	Enabled	Once initialized the USART2 configuration is: 8-bit, even parity and 1 Stop bit
	USART2_RX pin	Input	PA3 pin: USART2 in reception mode
	USART2_TX pin	Output	PA2 pin: USART2 in transmission mode
USARTx bootloaders	SysTick timer	Enabled	Used to automatically detect the serial baud rate from the host for USARTx bootloaders.
I2C1 bootloader	I2C1	Enabled	The I2C1 configuration is: I2C speed: up to 400 kHz, 7-bit address, slave mode, analog filter ON. Slave 7-bit address: 0b0111101x (where x = 0 for write and x = 1 for read)
	I2C1_SCL pin	Input/Output	PB6 pin: clock line is used in open-drain mode.
	I2C1_SDA pin	Input/Output	PB7 pin: data line is used in open-drain mode.

Table 43. STM32F318xx configuration in system memory boot mode (continued)

Bootloader	Feature/Peripheral	State	Comment
I2C3 bootloader	I2C3	Enabled	The I2C3 configuration is: I2C speed: up to 400 kHz, 7-bit address, slave mode, analog filter ON. Slave 7-bit address: 0b0111101x (where x = 0 for write and x = 1 for read) and digital filter disabled.
	I2C3_SCL pin	Input/Output	PA8 pin: clock line is used in open-drain mode.
	I2C3_SDA pin	Input/Output	PB5 pin: data line is used in open-drain mode.

The system clock is derived from the embedded internal high-speed RC, no external quartz is required for the bootloader execution.

21.2 Bootloader selection

The figure below shows the bootloader selection mechanism.

Figure 25. Bootloader selection for STM32F318xx

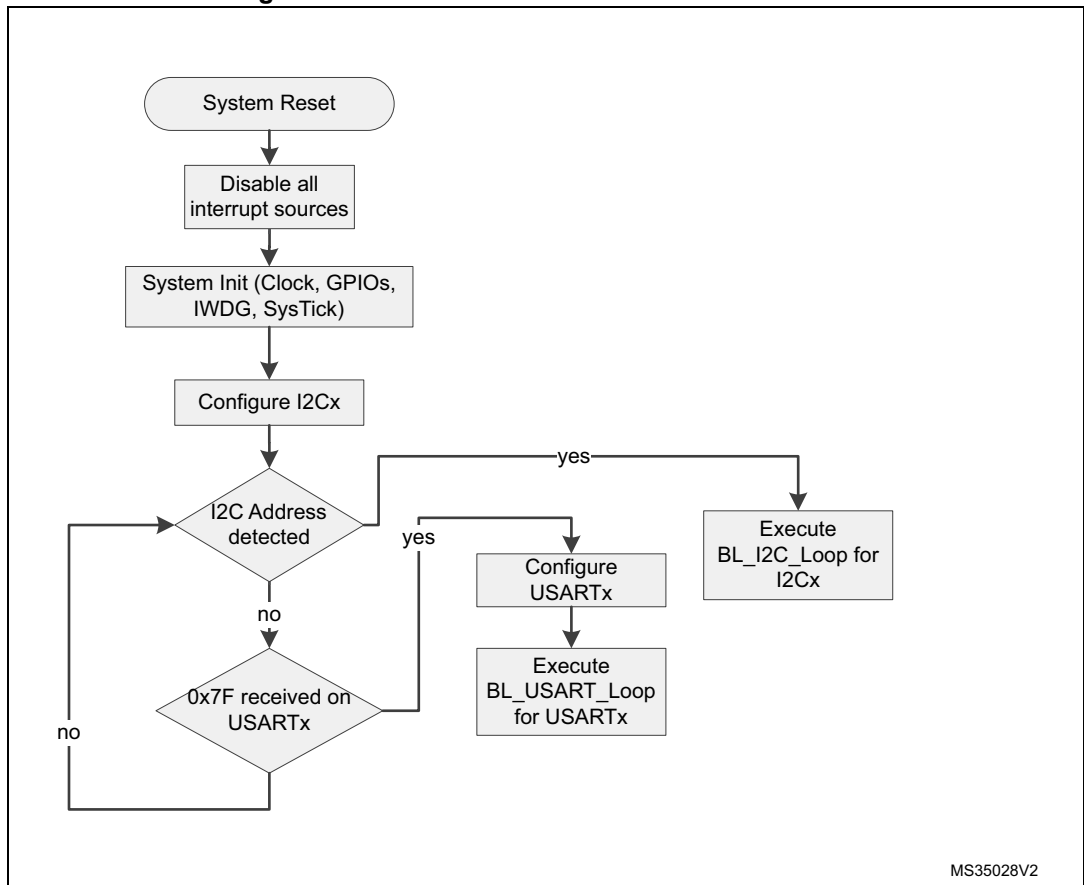

21.3 Bootloader version

The following table lists the STM32F318xx devices bootloader versions:

Table 44. STM32F318xx bootloader versions

Bootloader version number	Description	Known limitations
V5.0	Initial bootloader version	None

22 STM32F358xx devices bootloader

22.1 Bootloader configuration

The STM32F358xx bootloader is activated by applying Pattern 2 (described in [Table 2: Bootloader activation patterns](#)). The following table shows the hardware resources used by this bootloader.

Table 45. STM32F358xx configuration in system memory boot mode

Bootloader	Feature/Peripheral	State	Comment
Common to all bootloaders	RCC	HSI enabled	The system clock frequency is 8 MHz using the HSI.
	RAM	-	5 Kbyte starting from address 0x20000000 are used by the bootloader firmware.
	System memory	-	8 Kbyte starting from address 0x1FFFD800, contains the bootloader firmware.
	IWDG	-	The independent watchdog (IWDG) prescaler is configured to its maximum value and is periodically refreshed to prevent watchdog reset (in case the hardware IWDG option was previously enabled by the user). Window feature is disabled.
USART1 bootloader	USART1	Enabled	Once initialized, the USART1 configuration is: 8 bits, even parity and 1 Stop bit.
	USART1_RX pin	Input	PA10 pin: USART1 in reception mode.
	USART1_TX pin	Output	PA9 pin: USART1 in transmission mode.
USART2 bootloader	USART2	Enabled	Once initialized, the USART2 configuration is: 8 bits, even parity and 1 Stop bit. The USART2 uses its remapped pins.
	USART2_RX pin	Input	PD6 pin: USART2 in reception mode.
	USART2_TX pin	Output	PD5 pin: USART2 in transmission mode.
USARTx bootloaders	SysTick timer	Enabled	Used to automatically detect the serial baud rate from the host for USARTx bootloader.
I2C1 bootloader	I2C1	Enabled	The I2C1 configuration is: I2C speed: up to 400 kHz, 7-bit address, slave mode, analog filter ON. Slave 7-bit address: 0b0110111x (where x = 0 for write and x = 1 for read)
	I2C1_SCL pin	Input/Output	PB6 pin: clock line is used in open-drain mode.
	I2C1_SDA pin	Input/Output	PB7 pin: data line is used in open-drain mode.

The system clock is derived from the embedded internal high-speed RC, no external quartz is required for the bootloader execution.

22.2 Bootloader selection

The figure below shows the bootloader selection mechanism.

Figure 26. Bootloader selection for STM32F358xx devices

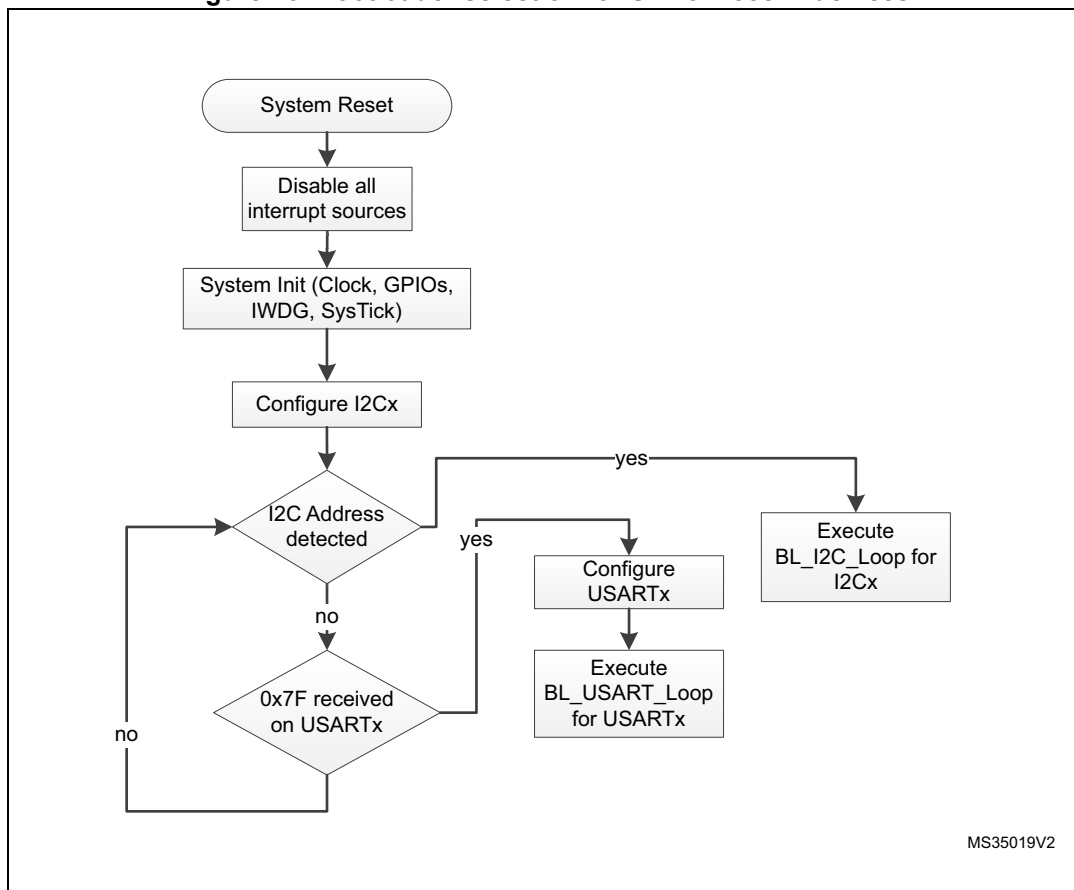

22.3 Bootloader version

The following table lists the STM32F358xx devices bootloader versions.

Table 46. STM32F358xx bootloader versions

Bootloader version number	Description	Known limitations
V5.0	Initial bootloader version	For USART1 and USART2 interfaces, the maximum baudrate supported by the bootloader is 57600 baud.

23 STM32F373xx devices bootloader

23.1 Bootloader configuration

The STM32F373xx bootloader is activated by applying Pattern 2 (described in [Table 2: Bootloader activation patterns](#)). The following table shows the hardware resources used by this bootloader.

Table 47. STM32F373xx configuration in system memory boot mode

Bootloader	Feature/Peripheral	State	Comment
Common to all bootloaders	RCC	HSI enabled	At startup, the system clock frequency is configured to 48 MHz using the HSI. If an external clock (HSE) is not present, the system is kept clocked from the HSI.
		HSE enabled	The external clock can be used for all bootloader interfaces and must have one the following values [24, 18, 16, 12, 9, 8, 6, 4, 3] MHz. The PLL is used to generate the USB 48 MHz clock and the 48 MHz clock for the system clock.
		-	The Clock Security System (CSS) interrupt is enabled for the DFU bootloader. Any failure (or removal) of the external clock generates system reset.
	RAM	-	5 Kbyte starting from address 0x20000000 are used by the bootloader firmware.
	System memory	-	8 Kbyte starting from address 0x1FFFD800, contains the bootloader firmware
	IWDG	-	The independent watchdog (IWDG) prescaler is configured to its maximum value and is periodically refreshed to prevent watchdog reset (in case the hardware IWDG option was previously enabled by the user).
USART1 bootloader	USART1	Enabled	Once initialized, the USART1 configuration is: 8 bits, even parity and 1 Stop bit.
	USART1_RX pin	Input	PA10 pin: USART1 in reception mode
	USART1_TX pin	Output	PA9 pin: USART1 in transmission mode
USART2 bootloader	USART2	Enabled	Once initialized, the USART2 configuration is: 8 bits, even parity and 1 Stop bit. The USART2 uses its remapped pins.
	USART2_RX pin	Input	PD6 pin: USART2 in reception mode
	USART2_TX pin	Output	PD5 pin: USART2 in transmission mode
USARTx bootloaders	SysTick timer	Enabled	Used to automatically detect the serial baud rate from the host for USARTx bootloader.

Table 47. STM32F373xx configuration in system memory boot mode (continued)

Bootloader	Feature/Peripheral	State	Comment
DFU bootloader	USB	Enabled	USB used in FS mode
	USB_DM pin	Input/Output	PA11: USB DM line.
	USB_DP pin		PA12: USB DP line An external pull-up resistor 1.5 KΩ must be connected to USB_DP pin.

The bootloader has two case of operation depending on the presence of the external clock (HSE) at bootloader startup:

- If HSE is present and has a value of 24, 18, 16, 12, 9, 8, 6, 4 or 3 MHz, the system clock is configured to 48 MHz with HSE as clock source. The DFU interface, USART1 and USART2 are functional and can be used to communicate with the bootloader device.
- If HSE is not present, the HSI is kept as default clock source and only USART1 and USART2 are functional.

Note: The external clock (HSE) must be kept if it is connected at bootloader startup because it is used as system clock source.

23.2 Bootloader selection

The figure below shows the bootloader selection mechanism.

Figure 27. Bootloader selection for STM32F373xx devices

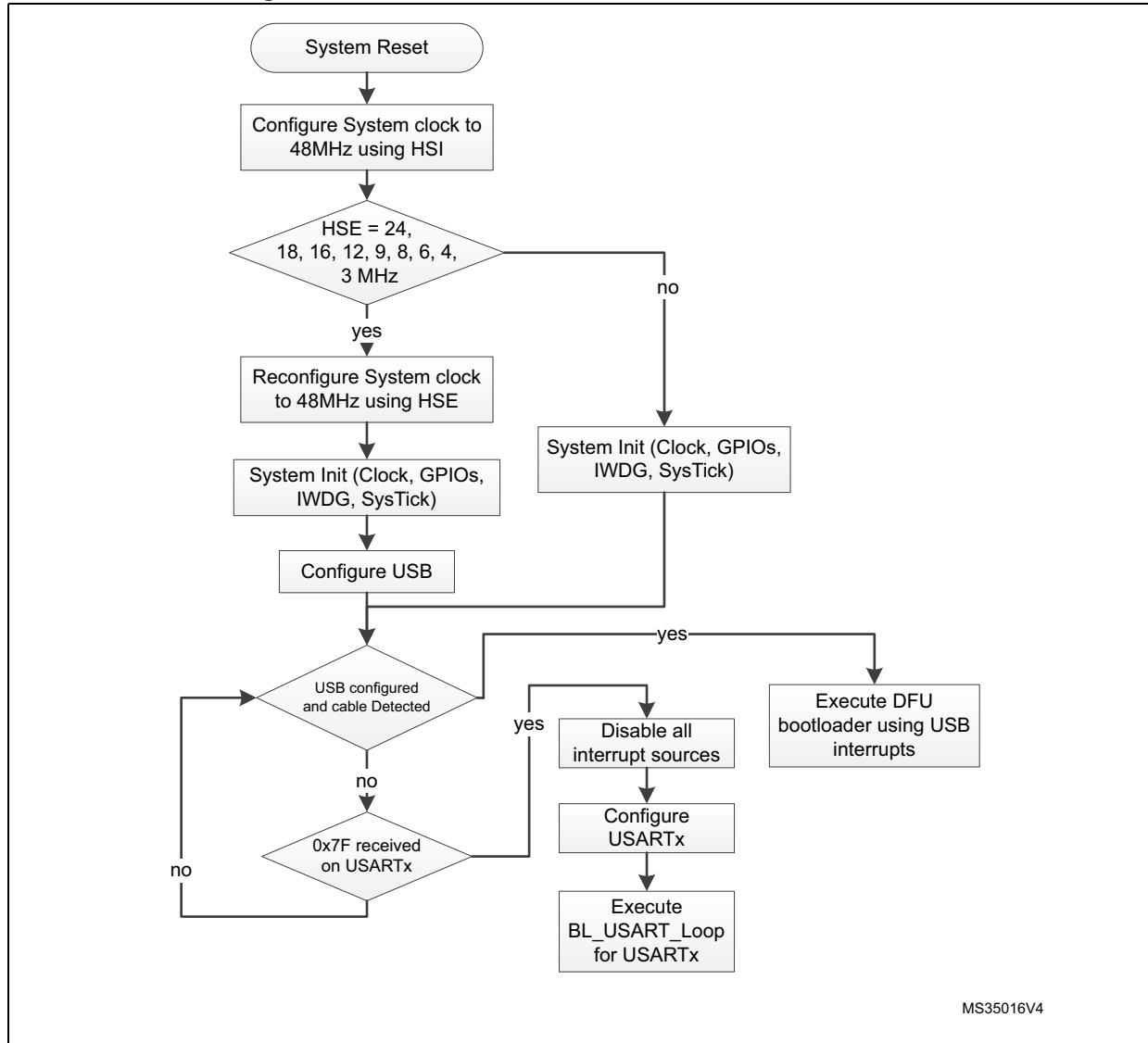

23.3 Bootloader version

The following table lists the STM32F373xx devices bootloader versions.

Table 48. STM32F373xx bootloader versions

Bootloader version number	Description	Known limitations
V4.1	Initial bootloader version	None

24 STM32F378xx devices bootloader

24.1 Bootloader configuration

The STM32F378xx bootloader is activated by applying Pattern 2 (described in [Table 2: Bootloader activation patterns](#)). The following table shows the hardware resources used by this bootloader.

Table 49. STM32F378xx configuration in system memory boot mode

Bootloader	Feature/Peripheral	State	Comment
Common to all bootloaders	RCC	HSI enabled	The system clock frequency is 8 MHz using the HSI.
	RAM	-	4 Kbyte starting from address 0x20000000 are used by the bootloader firmware.
	System memory	-	8 Kbyte starting from address 0x1FFFD800, contains the bootloader firmware
	IWDG	-	The independent watchdog (IWDG) prescaler is configured to its maximum value and is periodically refreshed to prevent watchdog reset (in case the hardware IWDG option was previously enabled by the user). Window feature is disabled.
USART1 bootloader	USART1	Enabled	Once initialized, the USART1 configuration is: 8 bits, even parity and 1 Stop bit
	USART1_RX pin	Input	PA10 pin: USART1 in reception mode.
	USART1_TX pin	Output	PA9 pin: USART1 in transmission mode.
USART2 bootloader	USART2	Enabled	Once initialized, the USART2 configuration is: 8 bits, even parity and 1 Stop bit. The USART2 uses its remapped pins.
	USART2_RX pin	Input	PD6 pin: USART2 in reception mode.
	USART2_TX pin	Output	PD5 pin: USART2 in transmission mode.
USARTx bootloaders	SysTick timer	Enabled	Used to automatically detect the serial baud rate from the host for USARTx bootloader.
I2C1 bootloader	I2C1	Enabled	The I2C1 configuration is: I2C speed: up to 400 kHz, 7-bit address, slave mode, analog filter ON. Slave 7-bit address: 0b0110111x (where x = 0 for write and x = 1 for read).
	I2C1_SCL pin	Input/Output	PB6 pin: clock line is used in open-drain mode.
	I2C1_SDA pin	Input/Output	PB7 pin: data line is used in open-drain mode.

The system clock is derived from the embedded internal high-speed RC, no external quartz is required for the bootloader execution.

24.2 Bootloader selection

The figure below shows the bootloader selection mechanism.

Figure 28. Bootloader selection for STM32F378xx devices

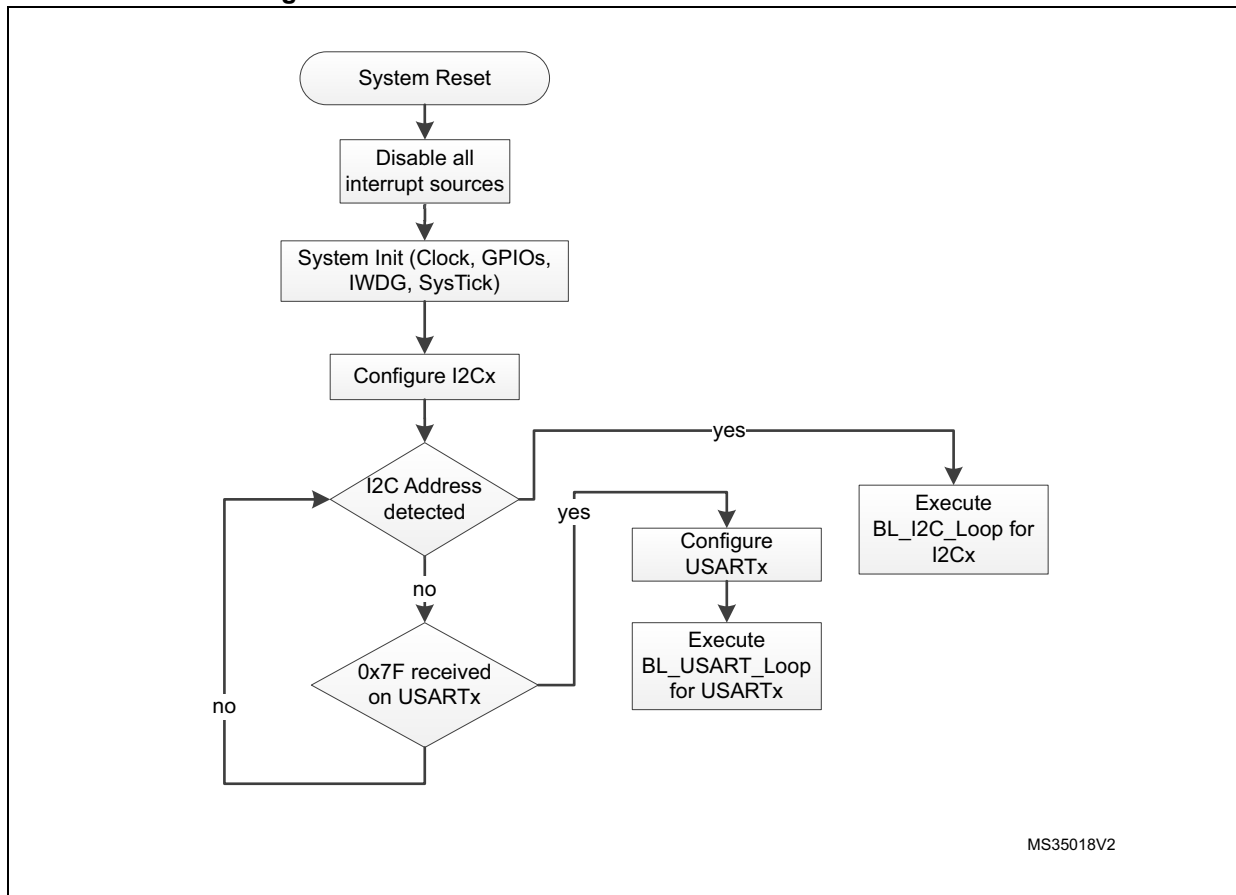

24.3 Bootloader version

The following table lists the STM32F378xx devices bootloader versions.

Table 50. STM32F378xx bootloader versions

Bootloader version number	Description	Known limitations
V5.0	Initial bootloader version	For USART1 and USART2 interfaces, the maximum baudrate supported by the bootloader is 57600 baud.

25 STM32F398xx devices bootloader

25.1 Bootloader configuration

The STM32F398xx bootloader is activated by applying Pattern 2 (described in [Table 2: Bootloader activation patterns](#)). The following table shows the hardware resources used by this bootloader.

Table 51. STM32F398xx configuration in system memory boot mode

Bootloader	Feature/Peripheral	State	Comment
Common to all bootloaders	RCC	HSI enabled	The system clock frequency is 60 MHz with HSI 8 MHz as clock source.
	RAM	-	6 Kbyte starting from address 0x20000000 are used by the bootloader firmware
	System memory	-	7 Kbyte starting from address 0x1FFFD800, contain the bootloader firmware
	IWDG	-	The independent watchdog (IWDG) prescaler is configured to its maximum value. It is periodically refreshed to prevent watchdog reset (in case the hardware IWDG option was previously enabled by the user).
USART1 bootloader	USART1	Enabled	Once initialized the USART1 configuration is: 8-bit, even parity and 1 Stop bit
	USART1_RX pin	Input	PA10 pin: USART1 in reception mode
	USART1_TX pin	Output	PA9 pin: USART1 in transmission mode
USART2 bootloader	USART2	Enabled	Once initialized the USART2 configuration is: 8-bit, even parity and 1 Stop bit
	USART2_RX pin	Input	PA3 pin: USART2 in reception mode
	USART2_TX pin	Output	PA2 pin: USART2 in transmission mode
USARTx bootloaders	SysTick timer	Enabled	Used to automatically detect the serial baud rate from the host for USARTx bootloaders.
I2C1 bootloader	I2C1	Enabled	The I2C1 configuration is: I2C speed: up to 400 kHz, 7-bit address, slave mode, analog filter ON. Slave 7-bit address: 0b1000000x (where x = 0 for write and x = 1 for read).
	I2C1_SCL pin	Input/Output	PB6 pin: clock line is used in open-drain mode.
	I2C1_SDA pin	Input/Output	PB7 pin: data line is used in open-drain mode.
I2C3 bootloader	I2C3	Enabled	The I2C3 configuration is: I2C speed: up to 400 kHz, 7-bit address, slave mode, analog filter ON. Slave 7-bit address: 0b1000000x (where x = 0 for write and x = 1 for read).
	I2C3_SCL pin	Input/Output	PA8 pin: clock line is used in open-drain mode.
	I2C3_SDA pin	Input/Output	PB5 pin: data line is used in open-drain mode.

The system clock is derived from the embedded internal high-speed RC for all bootloader interfaces. No external quartz is required for bootloader operations.

25.2 Bootloader selection

The figure below shows the bootloader selection mechanism.

Figure 29.Bootloader selection for STM32F398xx

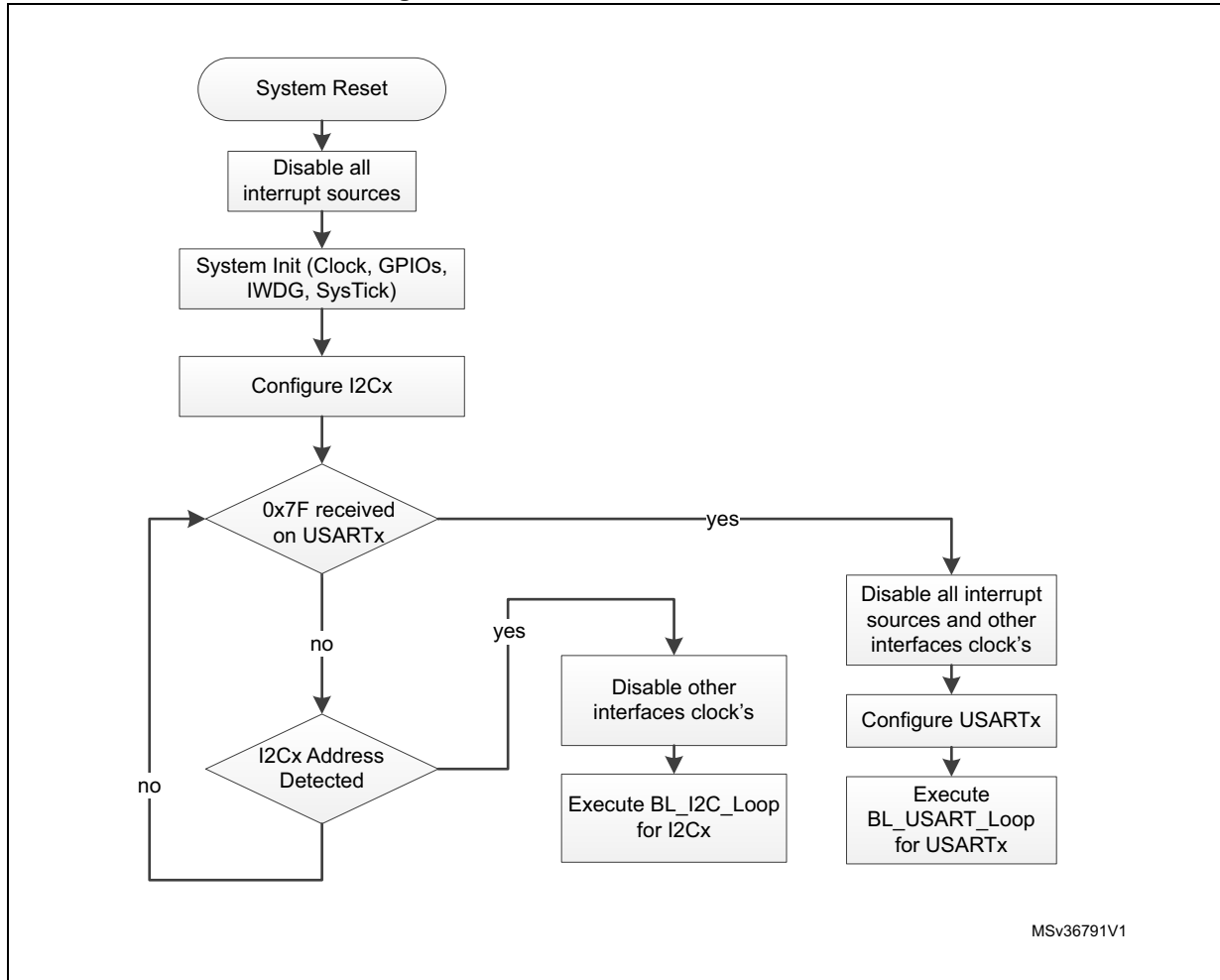

25.3 Bootloader version

The following table lists the STM32F398xx devices bootloader versions.

Table 52. STM32F398xx bootloader versions

Bootloader version number	Description	Known limitations
V5.0	Initial bootloader version	None

26 STM32F40xxx/41xxx devices bootloader

26.1 Bootloader V3.x

26.1.1 Bootloader configuration

The STM32F40xxx/41xxx bootloader is activated by applying Pattern 1 (described in [Table 2: Bootloader activation patterns](#)). The following table shows the hardware resources used by this bootloader.

Table 53. STM32F40xxx/41xxx configuration in system memory boot mode

Bootloader	Feature/Peripheral	State	Comment
Common to all bootloaders	RCC	HSI enabled	The system clock frequency is 24 MHz using the PLL. The HSI clock source is used at startup (interface detection phase) and when USARTx interfaces are selected (once CAN or DFU bootloader is selected, the clock source is derived from the external crystal).
		HSE enabled	The system clock frequency is 60 MHz. The HSE clock source is used only when the CAN or the DFU (USB FS Device) interfaces are selected. The external clock must provide a frequency multiple of 1 MHz and ranging from 4 MHz to 26 MHz.
		-	The Clock Security System (CSS) interrupt is enabled for the CAN and DFU bootloaders. Any failure (or removal) of the external clock generates system reset.
	RAM	-	8 Kbyte starting from address 0x20000000 are used by the bootloader firmware.
	System memory	-	29 Kbyte starting from address 0x1FFF0000 contain the bootloader firmware.
	IWDG	-	The independent watchdog (IWDG) prescaler is configured to its maximum value. It is periodically refreshed to prevent watchdog reset (in case the hardware IWDG option was previously enabled by the user).
	Power	-	Voltage range is set to [1.62 V, 2.1 V]. In this range internal Flash write operations are allowed only in byte format (Half-Word, Word and Double-Word operations are not allowed). The voltage range can be configured in run time using bootloader commands.

Table 53. STM32F40xxx/41xxx configuration in system memory boot mode (continued)

Bootloader	Feature/Peripheral	State	Comment
USART1 bootloader	USART1	Enabled	Once initialized, the USART1 configuration is: 8 bits, even parity and 1 Stop bit.
	USART1_RX pin	Input	PA10 pin: USART1 in reception mode
	USART1_TX pin	Output	PA9 pin: USART1 in transmission mode
USART3 bootloader (on PB10/PB11)	USART3	Enabled	Once initialized, the USART3 configuration is: 8 bits, even parity and 1 Stop bit.
	USART3_RX pin	Input	PB11 pin: USART3 in reception mode
	USART3_TX pin	Output	PB10 pin: USART3 in transmission mode
USART3 bootloader (on PC10/PC11)	USART3	Enabled	Once initialized, the USART3 configuration is: 8 bits, even parity and 1 Stop bit.
	USART3_RX pin	Input	PC11 pin: USART3 in reception mode
	USART3_TX pin	Output	PC10 pin: USART3 in transmission mode
USARTx bootloaders	SysTick timer	Enabled	Used to automatically detect the serial baud rate from the host for USARTx bootloaders.
CAN2 bootloader	CAN2	Enabled	Once initialized, the CAN2 configuration is: Baudrate 125 kbps, 11-bit identifier. Note: CAN1 is clocked during CAN2 bootloader execution because CAN1 manages the communication between CAN2 and SRAM.
	CAN2_RX pin	Input	PB5 pin: CAN2 in reception mode
	CAN2_TX pin	Output	PB13 pin: CAN2 in transmission mode
DFU bootloader	USB	Enabled	USB OTG FS configured in forced device mode
	USB_DM pin	Input/Output	PA11: USB DM line.
	USB_DP pin		PA12: USB DP line No external pull-up resistor is required
CAN2 and DFU bootloaders	TIM11	Enabled	This timer is used to determine the value of the HSE. Once the HSE frequency is determined, the system clock is configured to 60 MHz using PLL and HSE.

The system clock is derived from the embedded internal high-speed RC for USARTx bootloaders. This internal clock is also used for CAN and DFU (USB FS Device) but only for the selection phase. An external clock multiple of 1 MHz (between 4 and 26 MHz) is required for CAN and DFU bootloader execution after the selection phase.

Note: Due to HSI deviation and since HSI is used to detect HSE value, the user must use low frequency rather than high frequency HSE crystal values (low frequency values are better detected due to larger error margin). For example, it is better to use 8 MHz instead of 25 MHz.

26.1.2 Bootloader selection

The figure below shows the bootloader selection mechanism.

Figure 30. Bootloader V3.x selection for STM32F40xxx/41xxx devices

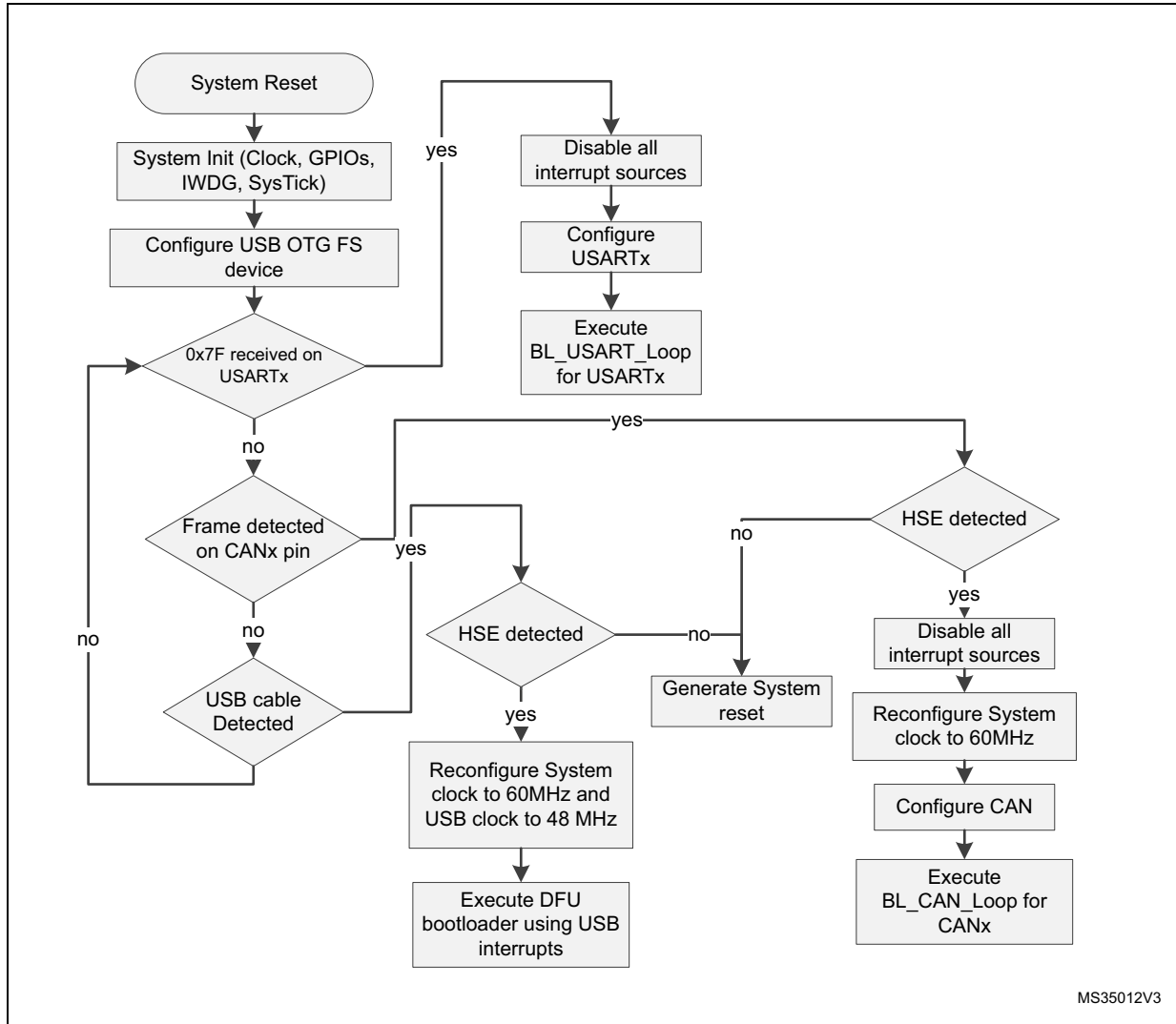

26.1.3 Bootloader version

The following table lists the STM32F40xxx/41xxx devices V3.x bootloader versions:

Table 54. STM32F40xxx/41xxx bootloader V3.x versions

Bootloader version number	Description	Known limitations
V3.0	Initial bootloader version	<ul style="list-style-type: none"> – When a Read Memory command or Write Memory command is issued with an unsupported memory address and a correct address checksum (i.e. address 0x6000 0000), the command is aborted by the bootloader device, but the NACK (0x1F) is not sent to the host. As a result, the next 2 bytes (which are the number of bytes to be read/written and its checksum) are considered as a new command and its checksum⁽¹⁾. – Option bytes, OTP and Device Feature descriptors (in DFU interface) are set to “g” instead of “e” (not erasable memory areas). <p>After executing Go command (jump to user code) the bootloader resets AHB1ENR value to 0x0000 0000 and thus CCM RAM, when present, is not active (must be re-enabled by user code at startup)</p>
V3.1	Fix V3.0 limitations. DFU interface robustness enhancement.	<ul style="list-style-type: none"> – For the USART interface, two consecutive NACKs (instead of 1 NACK) are sent when a Read Memory or Write Memory command is sent and the RDP level is active. – For the CAN interface, the Write Unprotect command is not functional. Use Write Memory command and write directly to the option bytes in order to disable the write protection. <p>After executing Go command (jump to user code) the bootloader resets AHB1ENR value to 0x0000 0000 and thus CCM RAM, when present, is not active (must be re-enabled by user code at startup)</p>

1. If the “number of data - 1” (N-1) to be read/written is not equal to a valid command code (0x00, 0x01, 0x02, 0x11, 0x21, 0x31, 0x43, 0x44, 0x63, 0x73, 0x82 or 0x92), then the limitation is not perceived from the host since the command is NACKed anyway (as an unsupported new command).

26.2 Bootloader V9.x

26.2.1 Bootloader configuration

The STM32F40xxx/41xxx bootloader is activated by applying Pattern 1 (described in [Table 2: Bootloader activation patterns](#)). [Table 55](#) shows the hardware resources used by this bootloader.

Note: The bootloader version V9.x is embedded only in STM32F405xx/415xx devices in WLCSP90 package.

Table 55. STM32F40xxx/41xxx configuration in system memory boot mode

Bootloader	Feature/Peripheral	State	Comment
Common to all bootloaders	RCC	HSI enabled	The system clock frequency is 60 MHz using the PLL. The HSI clock source is used at startup (interface detection phase) and when USART or SPI or I2C interfaces are selected (once CAN or DFU bootloader is selected, the clock source is derived from the external crystal).
		HSE enabled	The system clock frequency is 60 MHz. The HSE clock source is used only when the CAN or the DFU (USB FS Device) interfaces are selected. The external clock must provide a frequency multiple of 1 MHz and ranging from 4 MHz to 26 MHz.
		-	The Clock Security System (CSS) interrupt is enabled for the CAN and DFU bootloaders. Any failure (or removal) of the external clock generates system reset.
	RAM	-	12 Kbyte starting from address 0x20000000 are used by the bootloader firmware
	System memory	-	29 Kbyte starting from address 0x1FFF0000, contain the bootloader firmware
	IWDG	-	The independent watchdog (IWDG) prescaler is configured to its maximum value. It is periodically refreshed to prevent watchdog reset (in case the hardware IWDG option was previously enabled by the user).
	Power	-	Voltage range is set to [1.62 V, 2.1 V]. In this range internal Flash write operations are allowed only in byte format (Half-Word, Word and Double-Word operations are not allowed). The voltage range can be configured in run time using bootloader commands.

Table 55. STM32F40xxx/41xxx configuration in system memory boot mode (continued)

Bootloader	Feature/Peripheral	State	Comment
USART1 bootloader	USART1	Enabled	Once initialized the USART1 configuration is: 8-bit, even parity and 1 Stop bit
	USART1_RX pin	Input	PA10 pin: USART1 in reception mode
	USART1_TX pin	Output	PA9 pin: USART1 in transmission mode
USART3 bootloader (on PB10/PB11)	USART3	Enabled	Once initialized the USART3 configuration is: 8-bit, even parity and 1 Stop bit
	USART3_RX pin	Input	PB11 pin: USART3 in reception mode
	USART3_TX pin	Output	PB10 pin: USART3 in transmission mode
USART3 bootloader (on PC10/PC11)	USART3	Enabled	Once initialized the USART3 configuration is: 8-bit, even parity and 1 Stop bit
	USART3_RX pin	Input	PC11 pin: USART3 in reception mode
	USART3_TX pin	Output	PC10 pin: USART3 in transmission mode
USARTx bootloaders	SysTick timer	Enabled	Used to automatically detect the serial baud rate from the host for USARTx bootloaders.
CAN2 bootloader	CAN2	Enabled	Once initialized the CAN2 configuration is: Baudrate 125 kbps, 11-bit identifier. Note: CAN1 is clocked during CAN2 bootloader execution because CAN1 manages the communication between CAN2 and SRAM.
	CAN2_RX pin	Input	PB5 pin: CAN2 in reception mode
	CAN2_TX pin	Output	PB13 pin: CAN2 in transmission mode
I2C1 bootloader	I2C1	Enabled	The I2C1 configuration is: I2C speed: up to 400 kHz, 7-bit address, slave mode, analog filter ON. Slave 7-bit address: 0b0111010x (where x = 0 for write and x = 1 for read).
	I2C1_SCL pin	Input/Output	PB6 pin: clock line is used in open-drain mode.
	I2C1_SDA pin	Input/Output	PB7 pin: data line is used in open-drain mode.
I2C2 bootloader	I2C2	Enabled	The I2C2 configuration is: I2C speed: up to 400 kHz, 7-bit address, slave mode, analog filter ON. Slave 7-bit address: 0b0111010x (where x = 0 for write and x = 1 for read).
	I2C2_SCL pin	Input/Output	PF1 pin: clock line is used in open-drain mode.
	I2C2_SDA pin	Input/Output	PF0 pin: data line is used in open-drain mode.

Table 55. STM32F40xxx/41xxx configuration in system memory boot mode (continued)

Bootloader	Feature/Peripheral	State	Comment
I2C3 bootloader	I2C3	Enabled	The I2C3 configuration is: I2C speed: up to 400 kHz, 7-bit address, slave mode, analog filter ON. Slave 7-bit address: 0b0111010x (where x = 0 for write and x = 1 for read).
	I2C3_SCL pin	Input/Output	PA8 pin: clock line is used in open-drain mode.
	I2C3_SDA pin	Input/Output	PC9 pin: data line is used in open-drain mode.
SPI1 bootloader	SPI1	Enabled	The SPI1 configuration is: slave mode, Full Duplex, 8-bit MSB, Speed up to 8 MHz, Polarity: CPOL Low, CPHA Low, NSS hardware.
	SPI1_MOSI pin	Input	PA7 pin: Slave data Input line, used in push-pull, pull-down mode
	SPI1_MISO pin	Output	PA6 pin: Slave data output line, used in push-pull, pull-down mode
	SPI1_SCK pin	Input	PA5 pin: Slave clock line, used in push-pull, pull-down mode
	SPI1_NSS pin	Input	PA4 pin: slave chip select pin used in push-pull, pull-down mode.
SPI2 bootloader	SPI2	Enabled	The SPI2 configuration is: Slave mode, Full Duplex, 8-bit MSB, Speed up to 8 MHz, Polarity: CPOL Low, CPHA Low, NSS hardware.
	SPI2_MOSI pin	Input	PI3 pin: Slave data Input line, used in push-pull, pull-down mode
	SPI2_MISO pin	Output	PI2 pin: Slave data output line, used in push-pull, pull-down mode
	SPI2_SCK pin	Input	PI1 pin: Slave clock line, used in push-pull, pull-down mode
	SPI2_NSS pin	Input	PI0 pin: slave chip select pin used in push-pull, pull-down mode.
DFU bootloader	USB	Enabled	USB OTG FS configured in forced device mode
	USB_DM pin	Input/Output	PA11: USB DM line.
	USB_DP pin		PA12: USB DP line No external pull-up resistor is required
CAN2 and DFU bootloaders	TIM11	Enabled	This timer is used to determine the value of the HSE. Once the HSE frequency is determined, the system clock is configured to 60 MHz using PLL and HSE.

The system clock is derived from the embedded internal high-speed RC for USARTx, I2Cx and SPIx bootloaders. This internal clock is also used for CAN and DFU (USB FS Device) but only for the selection phase. An external clock multiple of 1 MHz (between 4 and 26 MHz) is required for CAN and DFU bootloader execution after the selection phase.

Note: Due to HSI deviation and since HSI is used to detect HSE value, the user must use low frequency rather than high frequency HSE crystal values (low frequency values are better detected due to larger error margin). For example, it is better to use 8 MHz instead of 25 MHz.

26.2.2 Bootloader selection

The figure below shows the bootloader selection mechanism.

Figure 31. Bootloader V9.x selection for STM32F40xxx/41xxx

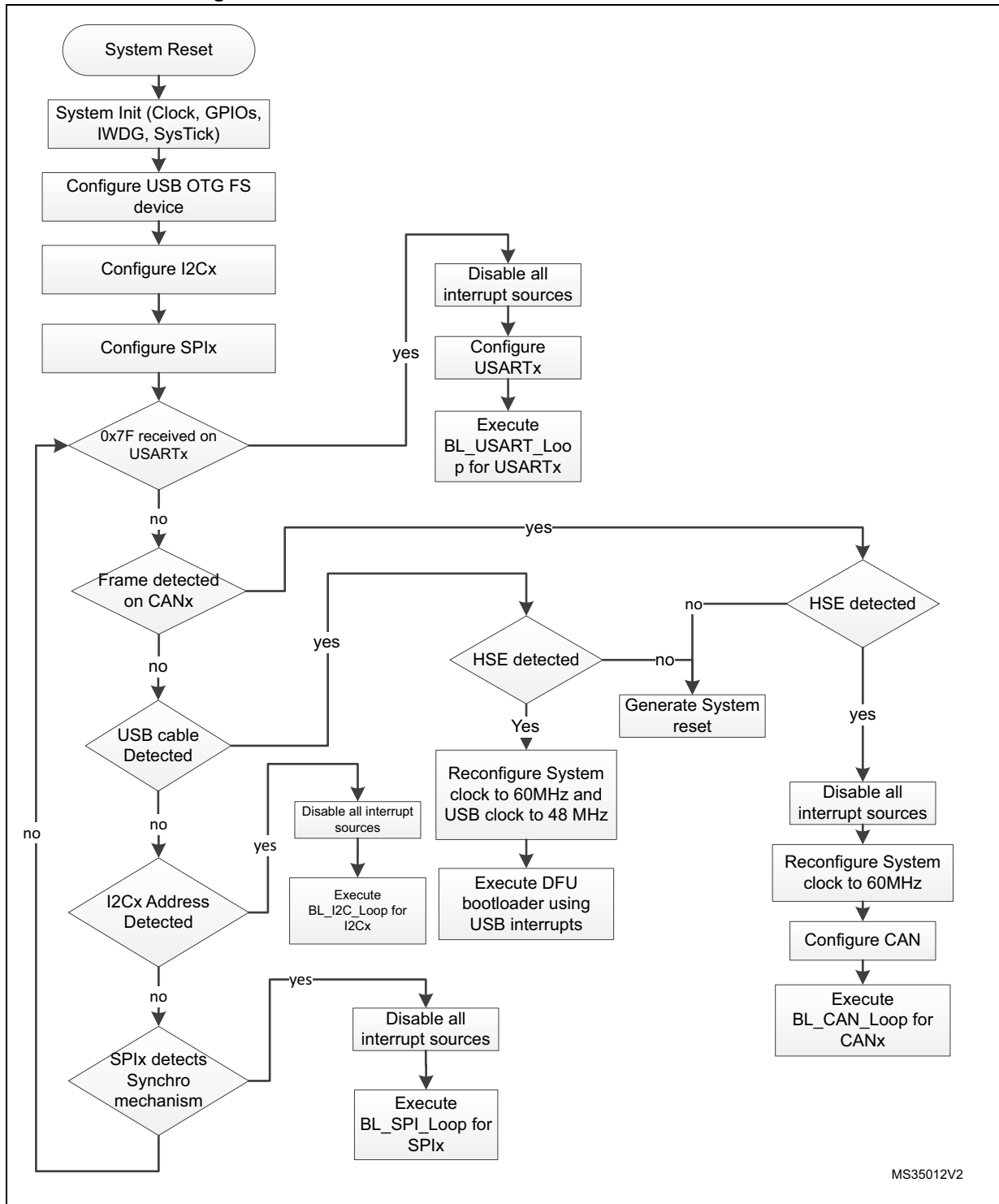

26.2.3 Bootloader version

The following table lists the STM32F40xxx/41xxx devices V9.x bootloader versions.

Table 56. STM32F40xxx/41xxx bootloader V9.x versions

Bootloader version number	Description	Known limitations
V9.0	<p>This bootloader is an updated version of bootloader v3.1.</p> <p>This new version of bootloader supports I2C1, I2C2, I2C3, SPI1 and SPI2 interfaces.</p> <p>The RAM used by this bootloader is increased from 8Kb to 12Kb.</p> <p>The ID of this bootloader is 0x90.</p> <p>The connection time is increased.</p>	<ul style="list-style-type: none"> - For the USART interface, two consecutive NACKs (instead of 1 NACK) are sent when a Read Memory or Write Memory command is sent and the RDP level is active. - For the CAN interface, the Write Unprotect command is not functional. Use Write Memory command and write directly to the option bytes in order to disable the write protection. <p>After executing Go command (jump to user code) the bootloader resets AHB1ENR value to 0x0000 0000 and thus CCM RAM, when present, is not active (must be re-enabled by user code at startup)</p>

27 STM32F401xB(C) devices bootloader

27.1 Bootloader configuration

The STM32F401xB(C) bootloader is activated by applying Pattern 1 (described in [Table 2: Bootloader activation patterns](#)). The following table shows the hardware resources used by this bootloader.

Table 57. STM32F401xB(C) configuration in system memory boot mode

Bootloader	Feature/Peripheral	State	Comment
Common to all bootloaders	RCC	HSI enabled	The system clock frequency is 60 MHz using the PLL. The HSI clock source is used at startup (interface detection phase) and when USART or SPI or I2C interface is selected (once DFU bootloader is selected, the clock source is derived from the external crystal).
		HSE enabled	The system clock frequency is 60 MHz. The HSE clock source is used only when the DFU (USB FS Device) interface is selected. The external clock must provide a frequency multiple of 1 MHz and ranging from 4 MHz to 26 MHz.
		-	The Clock Security System (CSS) interrupt is enabled for the CAN and DFU bootloaders. Any failure (or removal) of the external clock generates system reset.
	RAM	-	12 Kbyte starting from address 0x20000000 are used by the bootloader firmware
	System memory	-	29 Kbyte starting from address 0x1FFF0000, contain the bootloader firmware
	IWDG	-	The independent watchdog (IWDG) prescaler is configured to its maximum value. It is periodically refreshed to prevent watchdog reset (in case the hardware IWDG option was previously enabled by the user).
	Power	-	Voltage range is set to [1.62 V, 2.1 V]. In this range internal Flash write operations are allowed only in byte format (Half-Word, Word and Double-Word operations are not allowed). The voltage range can be configured in run time using bootloader commands.

Table 57. STM32F401xB(C) configuration in system memory boot mode (continued)

Bootloader	Feature/Peripheral	State	Comment
USART1 bootloader	USART1	Enabled	Once initialized the USART1 configuration is: 8-bit, even parity and 1 Stop bit
	USART1_RX pin	Input	PA10 pin: USART1 in reception mode
	USART1_TX pin	Output	PA9 pin: USART1 in transmission mode
USART2 bootloader	USART2	Enabled	Once initialized the USART2 configuration is: 8-bit, even parity and 1 Stop bit
	USART2_RX pin	Input	PD6 pin: USART2 in reception mode
	USART2_TX pin	Output	PD5 pin: USART2 in transmission mode
USARTx bootloaders	SysTick timer	Enabled	Used to automatically detect the serial baud rate from the host for USARTx bootloaders.
I2C1 bootloader	I2C1	Enabled	The I2C1 configuration is: I2C speed: up to 400 kHz, 7-bit address, slave mode, analog filter ON. Slave 7-bit address: 0b0111001x (where x = 0 for write and x = 1 for read)
	I2C1_SCL pin	Input/Output	PB6 pin: clock line is used in open-drain mode.
	I2C1_SDA pin	Input/Output	PB7 pin: data line is used in open-drain mode.
I2C2 bootloader	I2C2	Enabled	The I2C2 configuration is: I2C speed: up to 400 kHz, 7-bit address, slave mode, analog filter ON. Slave 7-bit address: 0b0111001x (where x = 0 for write and x = 1 for read)
	I2C2_SCL pin	Input/Output	PB10 pin: clock line is used in open-drain mode.
	I2C2_SDA pin	Input/Output	PB3 pin: data line is used in open-drain mode.
I2C3 bootloader	I2C3	Enabled	The I2C3 configuration is: I2C speed: up to 400 kHz, 7-bit address, slave mode, analog filter ON. Slave 7-bit address: 0b0111001x (where x = 0 for write and x = 1 for read)
	I2C3_SCL pin	Input/Output	PA8 pin: clock line is used in open-drain mode.
	I2C3_SDA pin	Input/Output	PB4 pin: data line is used in open-drain mode.

Table 57. STM32F401xB(C) configuration in system memory boot mode (continued)

Bootloader	Feature/Peripheral	State	Comment
SPI1 bootloader	SPI1	Enabled	The SPI1 configuration is: Slave mode, Full Duplex, 8-bit MSB, Speed up to 8 MHz, Polarity: CPOL Low, CPHA Low, NSS hardware.
	SPI1_MOSI pin	Input	PA7 pin: Slave data Input line, used in push-pull, pull-down mode
	SPI1_MISO pin	Output	PA6 pin: Slave data output line, used in push-pull, pull-down mode
	SPI1_SCK pin	Input	PA5 pin: Slave clock line, used in push-pull, pull-down mode
	SPI1_NSS pin	Input	PA4 pin: slave chip select pin used in push-pull, pull-down mode.
SPI2 bootloader	SPI2	Enabled	The SPI2 configuration is: Slave mode, Full Duplex, 8-bit MSB, Speed up to 8 MHz, Polarity: CPOL Low, CPHA Low, NSS hardware.
	SPI2_MOSI pin	Input	PB15 pin: Slave data Input line, used in push-pull, pull-down mode
	SPI2_MISO pin	Output	PB14 pin: Slave data output line, used in push-pull, pull-down mode
	SPI2_SCK pin	Input	PB13 pin: Slave clock line, used in push-pull, pull-down mode
	SPI2_NSS pin	Input	PB12 pin: slave chip select pin used in push-pull, pull-down mode.
SPI3 bootloader	SPI3	Enabled	The SPI3 configuration is: Slave mode, Full Duplex, 8-bit MSB, Speed up to 8 MHz, Polarity: CPOL Low, CPHA Low, NSS hardware.
	SPI3_MOSI pin	Input	PC12 pin: Slave data Input line, used in push-pull, pull-down mode
	SPI3_MISO pin	Output	PC11 pin: Slave data output line, used in push-pull, pull-down mode
	SPI3_SCK pin	Input	PC10 pin: Slave clock line, used in push-pull, pull-down mode
	SPI3_NSS pin	Input	PA15 pin: slave chip select pin used in push-pull, pull-down mode.

Table 57. STM32F401xB(C) configuration in system memory boot mode (continued)

Bootloader	Feature/Peripheral	State	Comment
DFU bootloader	USB	Enabled	USB OTG FS configured in forced device mode
	USB_DM pin	Input/Output	PA11: USB DM line.
	USB_DP pin		PA12: USB DP line No external pull-up resistor is required
	TIM11	Enabled	This timer is used to determine the value of the HSE. Once the HSE frequency is determined, the system clock is configured to 60 MHz using PLL and HSE.

The system clock is derived from the embedded internal high-speed RC for USARTx, I2Cx and SPIx bootloaders. This internal clock is also used for CAN and DFU (USB FS Device) but only for the selection phase. An external clock multiple of 1 MHz (between 4 and 26 MHz) is required for CAN and DFU bootloader execution after the selection phase.

Note: Due to HSI deviation and since HSI is used to detect HSE value, the user must use low frequency rather than high frequency HSE crystal values (low frequency values are better detected due to larger error margin). For example, it is better to use 8 MHz instead of 25 MHz.

27.2 Bootloader selection

The figure below shows the bootloader selection mechanism.

Figure 32. Bootloader selection for STM32F401xB(C)

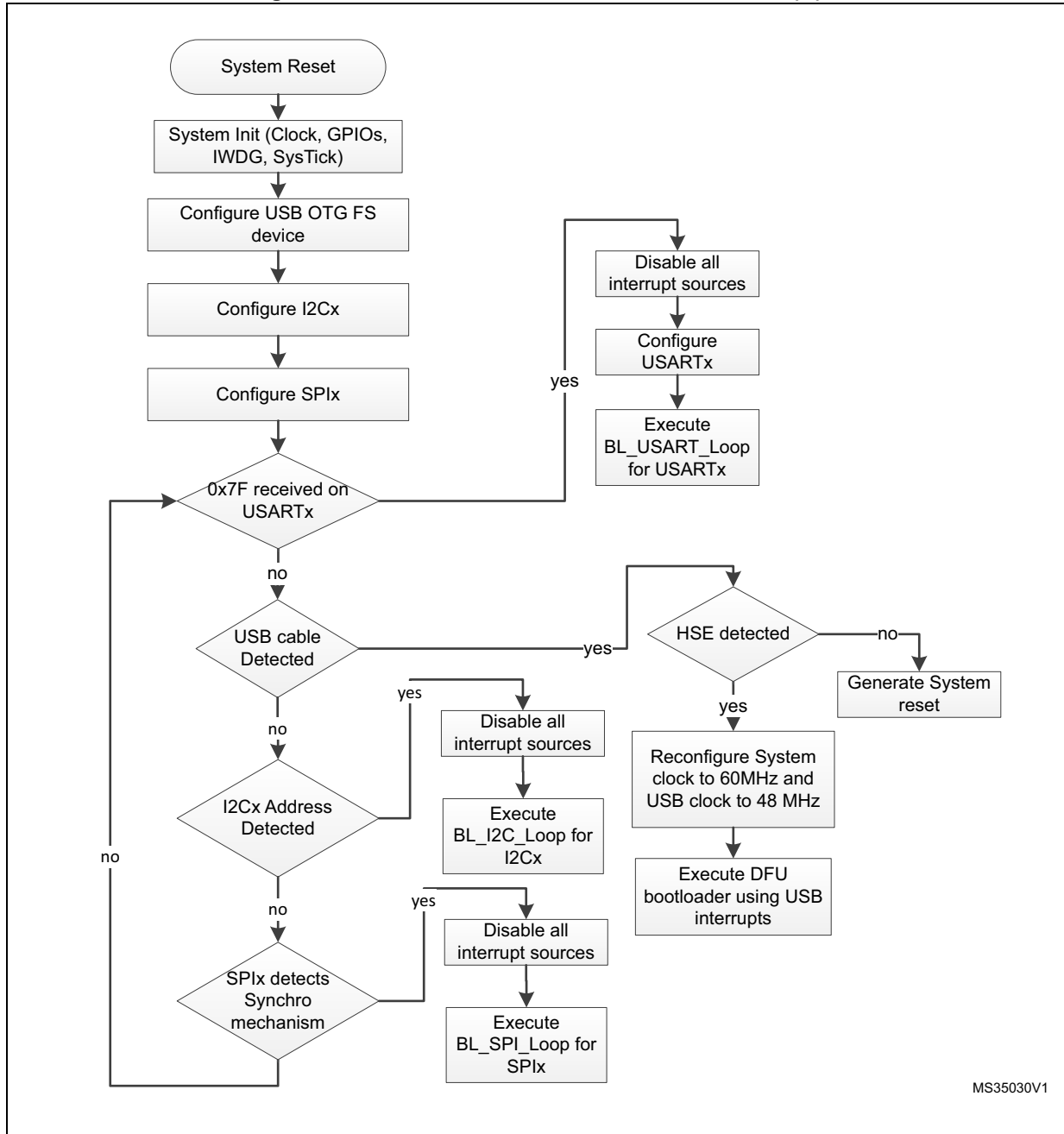

27.3 Bootloader version

The following table lists the STM32F401xB(C) devices bootloader version.

Table 58. STM32F401xB(C) bootloader versions

Bootloader version number	Description	Known limitations
V13.0	Initial bootloader version	After executing Go command (jump to user code) the bootloader resets AHB1ENR value to 0x0000 0000 and thus CCM RAM, when present, is not active (must be re-enabled by user code at startup)

28 STM32F401xD(E) devices bootloader

28.1 Bootloader configuration

The STM32F401xD(E) bootloader is activated by applying Pattern 1 (described in [Table 2: Bootloader activation patterns](#)). The following table shows the hardware resources used by this bootloader.

Table 59. STM32F401xD(E) configuration in system memory boot mode

Bootloader	Feature/Peripheral	State	Comment
Common to all bootloaders	RCC	HSI enabled	The system clock frequency is 60 MHz using the PLL. The HSI clock source is used at startup (interface detection phase) and when USART or SPI or I2C interface is selected (once DFU bootloader is selected, the clock source is derived from the external crystal).
		HSE enabled	The system clock frequency is 60 MHz. The HSE clock source is used only when the DFU (USB FS Device) interface is selected. The external clock must provide a frequency multiple of 1 MHz and ranging from 4 MHz to 26 MHz.
		-	The Clock Security System (CSS) interrupt is enabled for the DFU bootloader. Any failure (or removal) of the external clock generates system reset.
	RAM	-	12 Kbyte starting from address 0x20000000 are used by the bootloader firmware
	System memory	-	29 Kbyte starting from address 0x1FFF0000, contain the bootloader firmware
	IWDG	-	The independent watchdog (IWDG) prescaler is configured to its maximum value. It is periodically refreshed to prevent watchdog reset (in case the hardware IWDG option was previously enabled by the user).
	Power	-	Voltage range is set to [1.62 V, 2.1 V]. In this range internal Flash write operations are allowed only in byte format (Half-Word, Word and Double-Word operations are not allowed). The voltage range can be configured in run time using bootloader commands.
USART1 bootloader	USART1	Enabled	Once initialized the USART1 configuration is: 8-bit, even parity and 1 Stop bit
	USART1_RX pin	Input	PA10 pin: USART1 in reception mode
	USART1_TX pin	Output	PA9 pin: USART1 in transmission mode

Table 59. STM32F401xD(E) configuration in system memory boot mode (continued)

Bootloader	Feature/Peripheral	State	Comment
USART2 bootloader	USART2	Enabled	Once initialized the USART2 configuration is: 8-bit, even parity and 1 Stop bit
	USART2_RX pin	Input	PD6 pin: USART2 in reception mode
	USART2_TX pin	Output	PD5 pin: USART2 in transmission mode
USARTx bootloaders	SysTick timer	Enabled	Used to automatically detect the serial baud rate from the host for USARTx bootloaders.
I2C1 bootloader	I2C1	Enabled	The I2C1 configuration is: I2C speed: up to 400 kHz, 7-bit address, slave mode, analog filter ON. Slave 7-bit address: 0b0111001x (where x = 0 for write and x = 1 for read)
	I2C1_SCL pin	Input/Output	PB6 pin: clock line is used in open-drain mode.
	I2C1_SDA pin	Input/Output	PB7 pin: data line is used in open-drain mode.
I2C2 bootloader	I2C2	Enabled	The I2C2 configuration is: I2C speed: up to 400 kHz, 7-bit address, slave mode, analog filter ON. Slave 7-bit address: 0b0111001x (where x = 0 for write and x = 1 for read)
	I2C2_SCL pin	Input/Output	PB10 pin: clock line is used in open-drain mode.
	I2C2_SDA pin	Input/Output	PB3 pin: data line is used in open-drain mode.
I2C3 bootloader	I2C3	Enabled	The I2C3 configuration is: I2C speed: up to 400 kHz, 7-bit address, slave mode, analog filter ON. Slave 7-bit address: 0b0111001x (where x = 0 for write and x = 1 for read)
	I2C3_SCL pin	Input/Output	PA8 pin: clock line is used in open-drain mode.
	I2C3_SDA pin	Input/Output	PB4 pin: data line is used in open-drain mode.
SPI1 bootloader	SPI1	Enabled	The SPI1 configuration is: Slave mode, Full Duplex, 8-bit MSB, Speed up to 8 MHz, Polarity: CPOL Low, CPHA Low, NSS hardware.
	SPI1_MOSI pin	Input	PA7 pin: Slave data Input line, used in push-pull, pull-down mode
	SPI1_MISO pin	Output	PA6 pin: Slave data output line, used in push-pull, pull-down mode
	SPI1_SCK pin	Input	PA5 pin: Slave clock line, used in push-pull, pull-down mode
	SPI1_NSS pin	Input	PA4 pin: slave chip select pin used in push-pull, pull-down mode.

Table 59. STM32F401xD(E) configuration in system memory boot mode (continued)

Bootloader	Feature/Peripheral	State	Comment
SPI2 bootloader	SPI2	Enabled	The SPI2 configuration is: Slave mode, Full Duplex, 8-bit MSB, Speed up to 8 MHz, Polarity: CPOL Low, CPHA Low, NSS hardware.
	SPI2_MOSI pin	Input	PB15 pin: Slave data Input line, used in push-pull, pull-down mode
	SPI2_MISO pin	Output	PB14 pin: Slave data output line, used in push-pull, pull-down mode
	SPI2_SCK pin	Input	PB13 pin: Slave clock line, used in push-pull, pull-down mode
	SPI2_NSS pin	Input	PB12 pin: slave chip select pin used in push-pull, pull-down mode.
SPI3 bootloader	SPI3	Enabled	The SPI3 configuration is: Slave mode, Full Duplex, 8-bit MSB, Speed up to 8 MHz, Polarity: CPOL Low, CPHA Low, NSS hardware.
	SPI3_MOSI pin	Input	PC12 pin: Slave data Input line, used in push-pull, pull-down mode
	SPI3_MISO pin	Output	PC11 pin: Slave data output line, used in push-pull, pull-down mode
	SPI3_SCK pin	Input	PC10 pin: Slave clock line, used in push-pull, pull-down mode
	SPI3_NSS pin	Input	PA15 pin: slave chip select pin used in push-pull, pull-down mode.
DFU bootloader	USB	Enabled	USB OTG FS configured in forced device mode
	USB_DM pin	Input/Output	PA11: USB DM line.
	USB_DP pin		PA12: USB DP line No external pull-up resistor is required
	TIM11	Enabled	This timer is used to determine the value of the HSE. Once the HSE frequency is determined, the system clock is configured to 60 MHz using PLL and HSE.

The system clock is derived from the embedded internal high-speed RC for USARTx, I2Cx and SPIx bootloaders. This internal clock is also used for DFU (USB FS Device) but only for the selection phase. An external clock multiple of 1 MHz (between 4 and 26 MHz) is required for DFU bootloader execution after the selection phase.

Note: *Due to HSI deviation and since HSI is used to detect HSE value, the user must use low frequency rather than high frequency HSE crystal values (low frequency values are better detected due to larger error margin). For example, it is better to use 8 MHz instead of 25 MHz.*

28.2 Bootloader selection

The figure below shows the bootloader selection mechanism.

Figure 33. Bootloader selection for STM32F401xD(E)

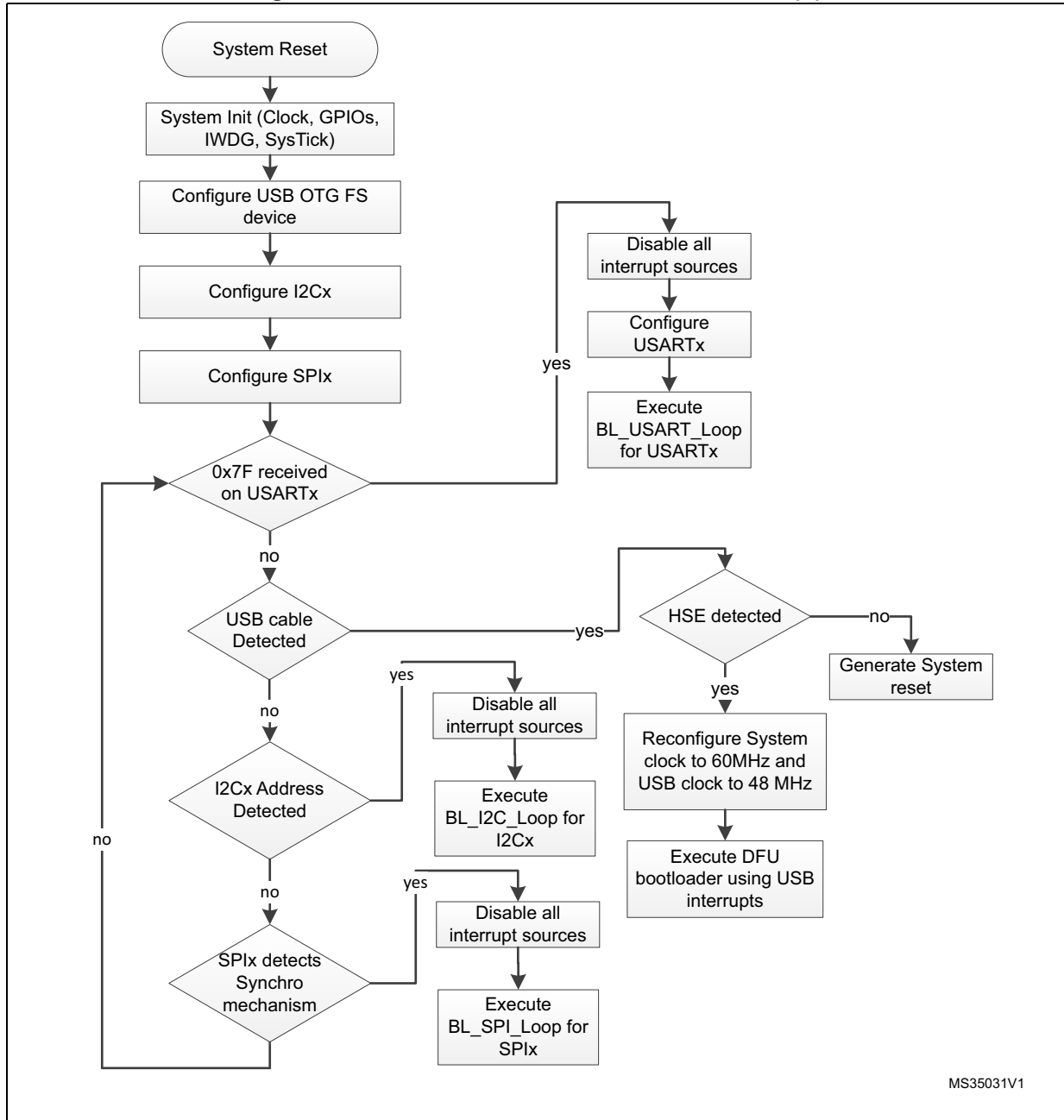

MS35031V1

28.3 Bootloader version

The following table lists the STM32F401xD(E) devices bootloader version.

Table 60. STM32F401xD(E) bootloader versions

Bootloader version number	Description	Known limitations
V13.1	Initial bootloader version	After executing Go command (jump to user code) the bootloader resets AHB1ENR value to 0x0000 0000 and thus CCM RAM, when present, is not active (must be re-enabled by user code at startup)

29 STM32F410xx devices bootloader

29.1 Bootloader configuration

The STM32F410xx bootloader is activated by applying Pattern 1 (described in [Table 2: Bootloader activation patterns](#)). The following table shows the hardware resources used by this bootloader.

Table 61. STM32F410xx configuration in system memory boot mode

Bootloader	Feature/Peripheral	State	Comment
Common to all bootloaders	RCC	HSI enabled	The HSI is used at startup as clock source for system clock configured to 60 MHz and for USART and I2C bootloader operation.
	RAM	-	5 Kbyte starting from address 0x20000000 are used by the bootloader firmware
	System memory	-	29 Kbyte starting from address 0x1FFF0000, contain the bootloader firmware
	IWDG	-	The independent watchdog (IWDG) prescaler is configured to its maximum value. It is periodically refreshed to prevent watchdog reset (in case the hardware IWDG option was previously enabled by the user).
	Power	-	The voltage range is [1.8V, 3.6V] In this range: - Flash wait states: 3. - System clock frequency 60 MHz. - ART Accelerator enabled. - Flash write operation by byte (refer to bootloader memory management section for more information).
USART1 bootloader	USART1	Enabled	Once initialized the USART1 configuration is: 8-bit, even parity and 1 Stop bit
	USART1_RX pin	Input	PA10 pin: USART1 in reception mode
	USART1_TX pin	Output	PA9 pin: USART1 in transmission mode
USART2 bootloader	USART2	Enabled	Once initialized the USART2 configuration is: 8-bit, even parity and 1 Stop bit
	USART2_RX pin	Input	PA3 pin: USART2 in reception mode
	USART2_TX pin	Output	PA2 pin: USART2 in transmission mode
USARTx bootloaders	SysTick timer	Enabled	Used to automatically detect the serial baud rate from the host for USARTx bootloaders.

Table 61. STM32F410xx configuration in system memory boot mode (continued)

Bootloader	Feature/Peripheral	State	Comment
I2C1 bootloader	I2C1	Enabled	The I2C1 configuration is: I2C speed: up to 400 kHz, 7-bit address, slave mode, analog filter ON. Slave 7-bit address: 0b1000111x (where x = 0 for write and x = 1 for read)
	I2C1_SCL pin	Input/Output	PB6 pin: clock line is used in open-drain mode.
	I2C1_SDA pin	Input/Output	PB7 pin: data line is used in open-drain mode.
I2C2 bootloader	I2C2	Enabled	The I2C2 configuration is: I2C speed: up to 400 kHz, 7-bit address, slave mode, analog filter ON. Slave 7-bit address: 0b1000111x (where x = 0 for write and x = 1 for read)
	I2C2_SCL pin	Input/Output	PB10 pin: clock line is used in open-drain mode.
	I2C2_SDA pin	Input/Output	PB11 pin: data line is used in open-drain mode.
I2C4 bootloader	I2C4	Enabled	The I2C4 configuration is: I2C speed: up to 1 MHz, 7-bit address, slave mode, analog filter ON. Slave 7-bit address: 0b1000111x (where x = 0 for write and x = 1 for read)
	I2C4_SCL pin	Input/Output	PB15 pin: clock line is used in open-drain mode for STM32F410Cx/Rx devices. PB10 pin: clock line is used in open-drain mode for STM32F410Tx devices.
	I2C4_SDA pin	Input/Output	PB14 pin: data line is used in open-drain mode for STM32F410Cx/Rx devices. PB3 pin: data line is used in open-drain mode for STM32F410Tx devices.

Table 61. STM32F410xx configuration in system memory boot mode (continued)

Bootloader	Feature/Peripheral	State	Comment
SPI1 bootloader	SPI1	Enabled	The SPI1 configuration is: Slave mode, Full Duplex, 8-bit MSB, Speed up to 8 MHz, Polarity: CPOL Low, CPHA Low, NSS hardware.
	SPI1_MOSI pin	Input	PA7 pin: Slave data Input line, used in push-pull, pull-down mode for STM32F410Cx/Rx devices. PB5 pin: Slave data Input line, used in push-pull, pull-down mode for STM32F410Tx devices.
	SPI1_MISO pin	Output	PA6 pin: Slave data output line, used in push-pull, pull-down mode for STM32F410Cx/Rx devices. PB4 pin: Slave data output line, used in push-pull, pull-down mode for STM32F410Tx devices.
	SPI1_SCK pin	Input	PA5 pin: Slave clock line, used in push- pull, pull-down mode.
	SPI1_NSS pin	Input	PA4 pin: slave chip select pin used in push-pull pull-up mode for STM32F410Cx/Rx devices. PA15 pin: slave chip select pin used in push-pull, pull-down mode for STM32F410Tx devices.
SPI2 bootloader	SPI2	Enabled	The SPI2 configuration is: Slave mode, Full Duplex, 8-bit MSB, Speed up to 8 MHz, Polarity: CPOL Low, CPHA Low, NSS hardware.
	SPI2_MOSI pin	Input	PC3 pin: Slave data Input line, used in push-pull, pull-down mode
	SPI2_MISO pin	Output	PC2 pin: Slave data output line, used in push-pull, pull-down mode
	SPI2_SCK pin	Input	PB13 pin: Slave clock line, used in push- pull, pull-down mode
	SPI2_NSS pin	Input	PB12 pin: slave chip select pin used in push-pull, pull-down mode.

The system clock is derived from the embedded internal high-speed RC for all bootloader interfaces. No external quartz is required for bootloader operations.

29.2 Bootloader selection

Figure 34 shows the bootloader selection mechanism.

Figure 34. Bootloader V11.x selection for STM32F410xx

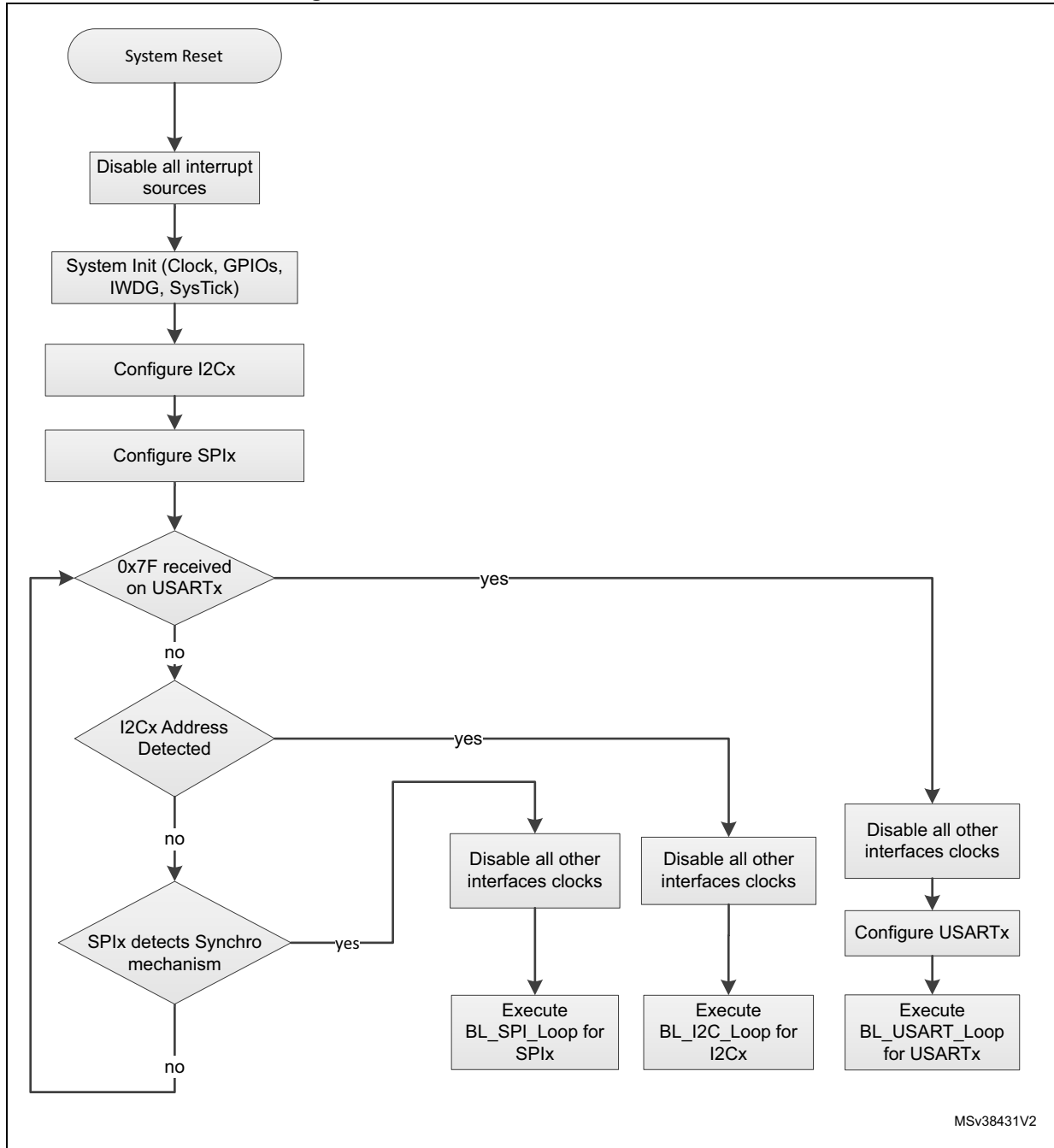

29.3 Bootloader version

The following table lists the STM32F410xx devices bootloader V11.x versions.

Table 62. STM32F410xx bootloader V11.x versions

Bootloader version number	Description	Known limitations
V11.0	Initial bootloader version	After executing Go command (jump to user code) the bootloader resets AHB1ENR value to 0x0000 0000 and thus CCM RAM, when present, is not active (must be re-enabled by user code at startup)
V11.1	Support I2C4 and SPI1 for STM32F410Tx devices.	After executing Go command (jump to user code) the bootloader resets AHB1ENR value to 0x0000 0000 and thus CCM RAM, when present, is not active (must be re-enabled by user code at startup)

30 STM32F411xx devices bootloader

30.1 Bootloader configuration

The STM32F411xx bootloader is activated by applying Pattern 1 (described in [Table 2: Bootloader activation patterns](#)). The following table shows the hardware resources used by this bootloader.

Table 63. STM32F411xx configuration in system memory boot mode

Bootloader	Feature/Peripheral	State	Comment
Common to all bootloaders	RCC	HSI enabled	The system clock frequency is 60 MHz using the PLL. The HSI clock source is used at startup (interface detection phase) and when USART or SPI or I2C interface is selected (once DFU bootloader is selected, the clock source is derived from the external crystal).
		HSE enabled	The system clock frequency is 60 MHz. The HSE clock source is used only when the DFU (USB FS Device) interface is selected. The external clock must provide a frequency multiple of 1 MHz and ranging from 4 MHz to 26 MHz.
		-	The Clock Security System (CSS) interrupt is enabled for the DFU bootloader. Any failure (or removal) of the external clock generates system reset.
	RAM	-	12 Kbyte starting from address 0x20000000 are used by the bootloader firmware
	System memory	-	29 Kbyte starting from address 0x1FFF0000, contain the bootloader firmware
	IWDG	-	The independent watchdog (IWDG) prescaler is configured to its maximum value. It is periodically refreshed to prevent watchdog reset (in case the hardware IWDG option was previously enabled by the user).
	Power	-	Voltage range is set to [1.62 V, 2.1 V]. In this range internal Flash write operations are allowed only in byte format (Half-Word, Word and Double-Word operations are not allowed). The voltage range can be configured in run time using bootloader commands.

Table 63. STM32F411xx configuration in system memory boot mode (continued)

Bootloader	Feature/Peripheral	State	Comment
USART1 bootloader	USART1	Enabled	Once initialized the USART1 configuration is: 8-bit, even parity and 1 Stop bit
	USART1_RX pin	Input	PA10 pin: USART1 in reception mode
	USART1_TX pin	Output	PA9 pin: USART1 in transmission mode
USART2 bootloader	USART2	Enabled	Once initialized the USART2 configuration is: 8-bit, even parity and 1 Stop bit
	USART2_RX pin	Input	PD6 pin: USART2 in reception mode
	USART2_TX pin	Output	PD5 pin: USART2 in transmission mode
USARTx bootloaders	SysTick timer	Enabled	Used to automatically detect the serial baud rate from the host for USARTx bootloaders.
I2C1 bootloader	I2C1	Enabled	The I2C1 configuration is: I2C speed: up to 400 kHz, 7-bit address, slave mode, analog filter ON. Slave 7-bit address: 0b0111001x (where x = 0 for write and x = 1 for read)
	I2C1_SCL pin	Input/Output	PB6 pin: clock line is used in open-drain mode.
	I2C1_SDA pin	Input/Output	PB7 pin: data line is used in open-drain mode.
I2C2 bootloader	I2C2	Enabled	The I2C2 configuration is: I2C speed: up to 400 kHz, 7-bit address, slave mode, analog filter ON. Slave 7-bit address: 0b0111001x (where x = 0 for write and x = 1 for read)
	I2C2_SCL pin	Input/Output	PB10 pin: clock line is used in open-drain mode.
	I2C2_SDA pin	Input/Output	PB3 pin: data line is used in open-drain mode.
I2C3 bootloader	I2C3	Enabled	The I2C3 configuration is: I2C speed: up to 400 kHz, 7-bit address, slave mode, analog filter ON. Slave 7-bit address: 0b0111001x (where x = 0 for write and x = 1 for read)
	I2C3_SCL pin	Input/Output	PA8 pin: clock line is used in open-drain mode.
	I2C3_SDA pin	Input/Output	PB4 pin: data line is used in open-drain mode.

Table 63. STM32F411xx configuration in system memory boot mode (continued)

Bootloader	Feature/Peripheral	State	Comment
SPI1 bootloader	SPI1	Enabled	The SPI1 configuration is: Slave mode, Full Duplex, 8-bit MSB, Speed up to 8 MHz, Polarity: CPOL Low, CPHA Low, NSS hardware.
	SPI1_MOSI pin	Input	PA7 pin: Slave data Input line, used in push-pull, pull-down mode
	SPI1_MISO pin	Output	PA6 pin: Slave data output line, used in push-pull, pull-down mode
	SPI1_SCK pin	Input	PA5 pin: Slave clock line, used in push-pull, pull-down mode
	SPI1_NSS pin	Input	PA4 pin: slave chip select pin used in push-pull, pull-down mode.
SPI2 bootloader	SPI2	Enabled	The SPI2 configuration is: Slave mode, Full Duplex, 8-bit MSB, Speed up to 8 MHz, Polarity: CPOL Low, CPHA Low, NSS hardware.
	SPI2_MOSI pin	Input	PB15 pin: Slave data Input line, used in push-pull, pull-down mode
	SPI2_MISO pin	Output	PB14 pin: Slave data output line, used in push-pull, pull-down mode
	SPI2_SCK pin	Input	PB13 pin: Slave clock line, used in push-pull, pull-down mode
	SPI2_NSS pin	Input	PB12 pin: slave chip select pin used in push-pull, pull-down mode.
SPI3 bootloader	SPI3	Enabled	The SPI3 configuration is: Slave mode, Full Duplex, 8-bit MSB, Speed up to 8 MHz, Polarity: CPOL Low, CPHA Low, NSS hardware.
	SPI3_MOSI pin	Input	PC12 pin: Slave data Input line, used in push-pull, pull-down mode
	SPI3_MISO pin	Output	PC11 pin: Slave data output line, used in push-pull, pull-down mode
	SPI3_SCK pin	Input	PC10 pin: Slave clock line, used in push-pull, pull-down mode
	SPI3_NSS pin	Input	PA15 pin: slave chip select pin used in push-pull, pull-down mode.

Table 63. STM32F411xx configuration in system memory boot mode (continued)

Bootloader	Feature/Peripheral	State	Comment
DFU bootloader	USB	Enabled	USB OTG FS configured in forced device mode
	USB_DM pin	Input/Output	PA11: USB DM line.
	USB_DP pin		PA12: USB DP line No external pull-up resistor is required
	TIM11	Enabled	This timer is used to determine the value of the HSE. Once the HSE frequency is determined, the system clock is configured to 60 MHz using PLL and HSE.

The system clock is derived from the embedded internal high-speed RC for USARTx, I2Cx and SPIx bootloaders. This internal clock is also used for DFU (USB FS Device) but only for the selection phase. An external clock multiple of 1 MHz (between 4 and 26 MHz) is required for DFU bootloader execution after the selection phase.

Note: Due to HSI deviation and since HSI is used to detect HSE value, the user must use low frequency rather than high frequency HSE crystal values (low frequency values are better detected due to larger error margin). For example, it is better to use 8 MHz instead of 25 MHz.

30.2 Bootloader selection

The figure below shows the bootloader selection mechanism.

Figure 35. Bootloader selection for STM32F411xx

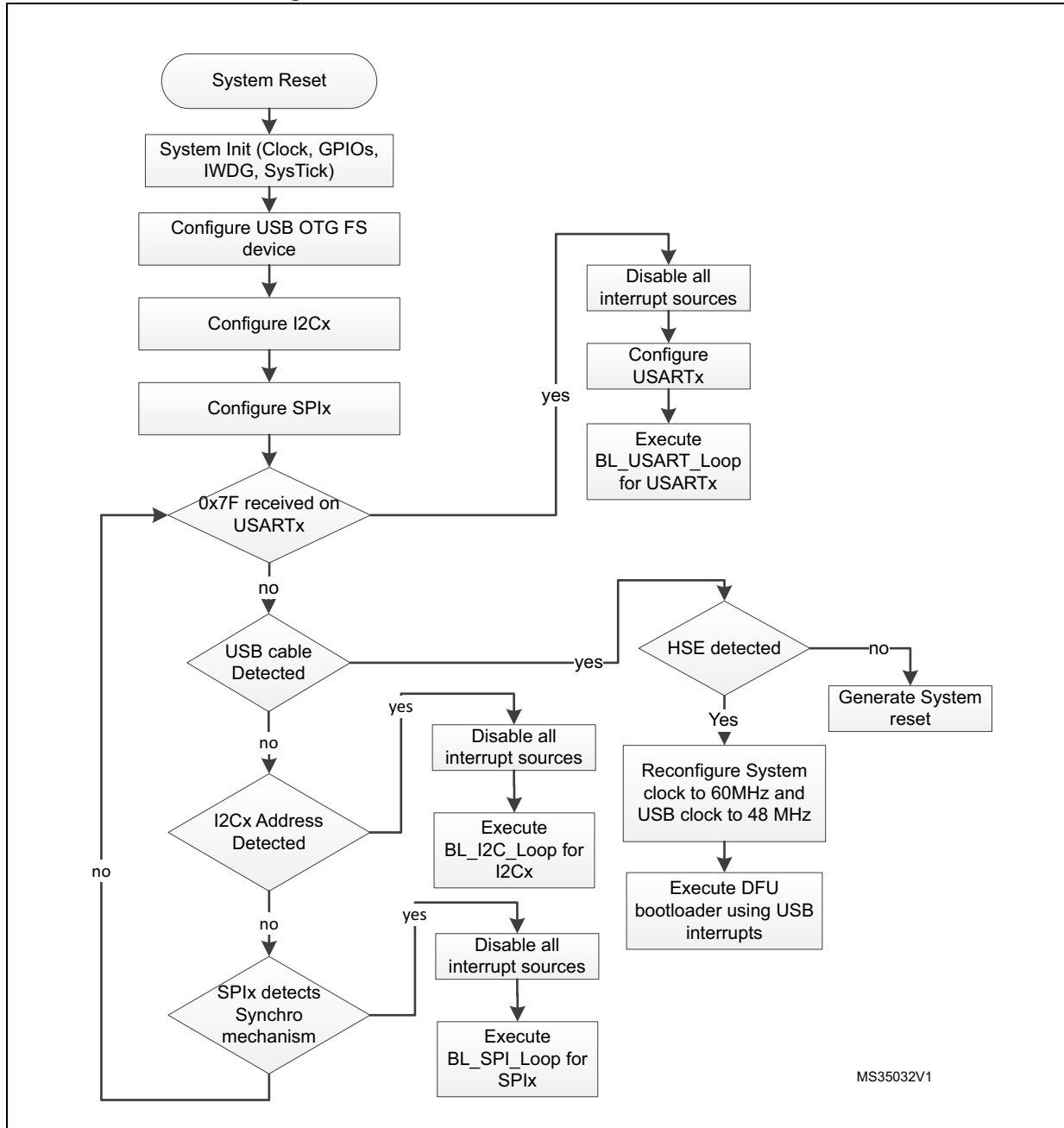

30.3 Bootloader version

The following table lists the STM32F411xx devices bootloader version.

Table 64. STM32F411xx bootloader versions

Bootloader version number	Description	Known limitations
V13.0	Initial bootloader version	After executing Go command (jump to user code) the bootloader resets AHB1ENR value to 0x0000 0000 and thus CCM RAM, when present, is not active (must be re-enabled by user code at startup)

31 STM32F412xx devices bootloader

31.1 Bootloader configuration

The STM32F412xx bootloader is activated by applying Pattern 1 (described in [Table 2: Bootloader activation patterns](#)). The table shows the hardware resources used by this bootloader.

Table 65. STM32F412xx configuration in system memory boot mode

Bootloader	Feature/Peripheral	State	Comment
Common to all bootloaders	RCC	HSI enabled	The HSI is used at startup as clock source for system clock configured to 60 MHz and for USART and I2C bootloader operation.
		HSE enabled	The HSE is used only when the CAN or the DFU (USB FS Device) interfaces are selected. In this case the system clock configured to 60 MHz with HSE as clock source. The HSE frequency must be multiple of 1 MHz and ranging from 4 MHz to 26 MHz.
		-	The Clock Security System (CSS) interrupt is enabled for the CAN and DFU bootloaders. Any failure (or removal) of the external clock generates system reset.
	RAM	-	16 Kbyte starting from address 0x20000000 are used by the bootloader firmware
	System memory	-	29 Kbyte starting from address 0x1FFF0000, contain the bootloader firmware
	IWDG	-	The independent watchdog (IWDG) prescaler is configured to its maximum value. It is periodically refreshed to prevent watchdog reset (in case the hardware IWDG option was previously enabled by the user).
	Power	-	The voltage range is [1.8V, 3.6V] In this range: - Flash wait states: 3. - System clock frequency 60 MHz. - ART Accelerator enabled. - Flash write operation by byte (refer to bootloader memory management section for more information).
USART1 bootloader	USART1	Enabled	Once initialized the USART1 configuration is: 8-bit, even parity and 1 Stop bit
	USART1_RX pin	Input	PA10 pin: USART1 in reception mode
	USART1_TX pin	Output	PA9 pin: USART1 in transmission mode

Table 65. STM32F412xx configuration in system memory boot mode (continued)

Bootloader	Feature/Peripheral	State	Comment
USART2 bootloader	USART2	Enabled	Once initialized the USART2 configuration is: 8-bit, even parity and 1 Stop bit
	USART2_RX pin	Input	PD6 pin: USART2 in reception mode
	USART2_TX pin	Output	PD5 pin: USART2 in transmission mode
USART3 bootloader	USART3	Enabled	Once initialized the USART3 configuration is: 8-bit, even parity and 1 Stop bit
	USART3_RX pin	Input	PB11 pin: USART3 in reception mode
	USART3_TX pin	Output	PB10 pin: USART3 in transmission mode
USARTx bootloaders	SysTick timer	Enabled	Used to automatically detect the serial baud rate from the host for USARTx bootloaders.
CAN2 bootloader	CAN2	Enabled	Once initialized the CAN2 configuration is: Baudrate 125 kbps, 11-bit identifier. Note: CAN1 is clocked during CAN2 bootloader execution because CAN1 manages the communication between CAN2 and SRAM.
	CAN2_RX pin	Input	PB5 pin: CAN2 in reception mode
	CAN2_TX pin	Output	PB13 pin: CAN2 in transmission mode
I2C1 bootloader	I2C1	Enabled	The I2C1 configuration is: I2C speed: up to 400 kHz, 7-bit address, slave mode, analog filter ON. Slave 7-bit address: 0b1000110x (where x = 0 for write and x = 1 for read)
	I2C1_SCL pin	Input/Output	PB6 pin: clock line is used in open-drain mode.
	I2C1_SDA pin	Input/Output	PB7 pin: data line is used in open-drain mode.
I2C2 bootloader	I2C2	Enabled	The I2C2 configuration is: I2C speed: up to 400 kHz, 7-bit address, slave mode, analog filter ON. Slave 7-bit address: 0b1000110x (where x = 0 for write and x = 1 for read)
	I2C2_SCL pin	Input/Output	PF1 pin: clock line is used in open-drain mode.
	I2C2_SDA pin	Input/Output	PF0 pin: data line is used in open-drain mode.

Table 65. STM32F412xx configuration in system memory boot mode (continued)

Bootloader	Feature/Peripheral	State	Comment
I2C3 bootloader	I2C3	Enabled	The I2C3 configuration is: I2C speed: up to 400 kHz, 7-bit address, slave mode, analog filter ON. Slave 7-bit address: 0b1000110x (where x = 0 for write and x = 1 for read)
	I2C3_SCL pin	Input/Output	PA8 pin: clock line is used in open-drain mode.
	I2C3_SDA pin	Input/Output	PB4 pin: data line is used in open-drain mode.
I2C4 bootloader	I2C4	Enabled	The I2C4 configuration is: I2C speed: up to 1 MHz, 7-bit address, slave mode, analog filter ON. Slave 7-bit address: 0b1000110x (where x = 0 for write and x = 1 for read)
	I2C4_SCL pin	Input/Output	PB15 pin: clock line is used in open-drain mode.
	I2C4_SDA pin	Input/Output	PB14 pin: data line is used in open-drain mode.
SPI1 bootloader	SPI1	Enabled	The SPI1 configuration is: Slave mode, Full Duplex, 8-bit MSB, Speed up to 8 MHz, Polarity: CPOL Low, CPHA Low, NSS hardware.
	SPI1_MOSI pin	Input	PA7 pin: Slave data Input line, used in push-pull, pull-down mode
	SPI1_MISO pin	Output	PA6 pin: Slave data output line, used in push-pull, pull-down mode
	SPI1_SCK pin	Input	PA5 pin: Slave clock line, used in push-pull, pull-down mode
	SPI1_NSS pin	Input	PA4 pin: slave chip select pin used in push-pull pull-up mode.
SPI3 bootloader	SPI3	Enabled	The SPI3 configuration is: Slave mode, Full Duplex, 8-bit MSB, Speed up to 8 MHz, Polarity: CPOL Low, CPHA Low, NSS hardware.
	SPI3_MOSI pin	Input	PC12 pin: Slave data Input line, used in push-pull, pull-down mode
	SPI3_MISO pin	Output	PC11 pin: Slave data output line, used in push-pull, pull-down mode
	SPI3_SCK pin	Input	PC10 pin: Slave clock line, used in push-pull, pull-down mode
	SPI3_NSS pin	Input	PA15 pin: slave chip select pin used in push-pull pull-up mode.

Table 65. STM32F412xx configuration in system memory boot mode (continued)

Bootloader	Feature/Peripheral	State	Comment
SPI4 bootloader	SPI4	Enabled	The SPI4 configuration is: Slave mode, Full Duplex, 8-bit MSB, Speed up to 8 MHz, Polarity: CPOL Low, CPHA Low, NSS hardware.
	SPI4_MOSI pin	Input	PE14 pin: Slave data Input line, used in push-pull, pull-down mode
	SPI4_MISO pin	Output	PE13 pin: Slave data output line, used in push-pull, pull-down mode
	SP4_SCK pin	Input	PE12 pin: Slave clock line, used in push-pull, pull-down mode
	SPI4_NSS pin	Input	PE11 pin: slave chip select pin used in push-pull pull-up mode.
DFU bootloader	USB	Enabled	USB OTG FS configured in forced device mode
	USB_DM pin	Input/Output	PA11 pin: USB DM line.
	USB_DP pin		PA12 pin: USB DP line No external Pull-Up resistor is required.
CAN2 and DFU bootloaders	TIM11	Enabled	This timer is used to determine the value of the HSE. Once HSE frequency is determined, the system clock is configured to 60 MHz using PLL and HSE.

The system clock is derived from the embedded internal high-speed RC for USARTx and I2Cx bootloaders. This internal clock is also used for CAN and DFU (USB FS Device) but only for the selection phase. An external clock multiple of 1 MHz (between 4 and 26 MHz) is required for CAN and DFU bootloader execution after the selection phase.

Note: Due to HSI deviation and since HSI is used to detect HSE value, the user must use low frequency rather than high frequency HSE crystal values (low frequency values are better detected due to larger error margin). For example, it is better to use 8 MHz instead of 25 MHz.

31.2 Bootloader selection

Figure 36 shows the bootloader selection mechanism.

Figure 36.Bootloader V9.x selection for STM32F412xx

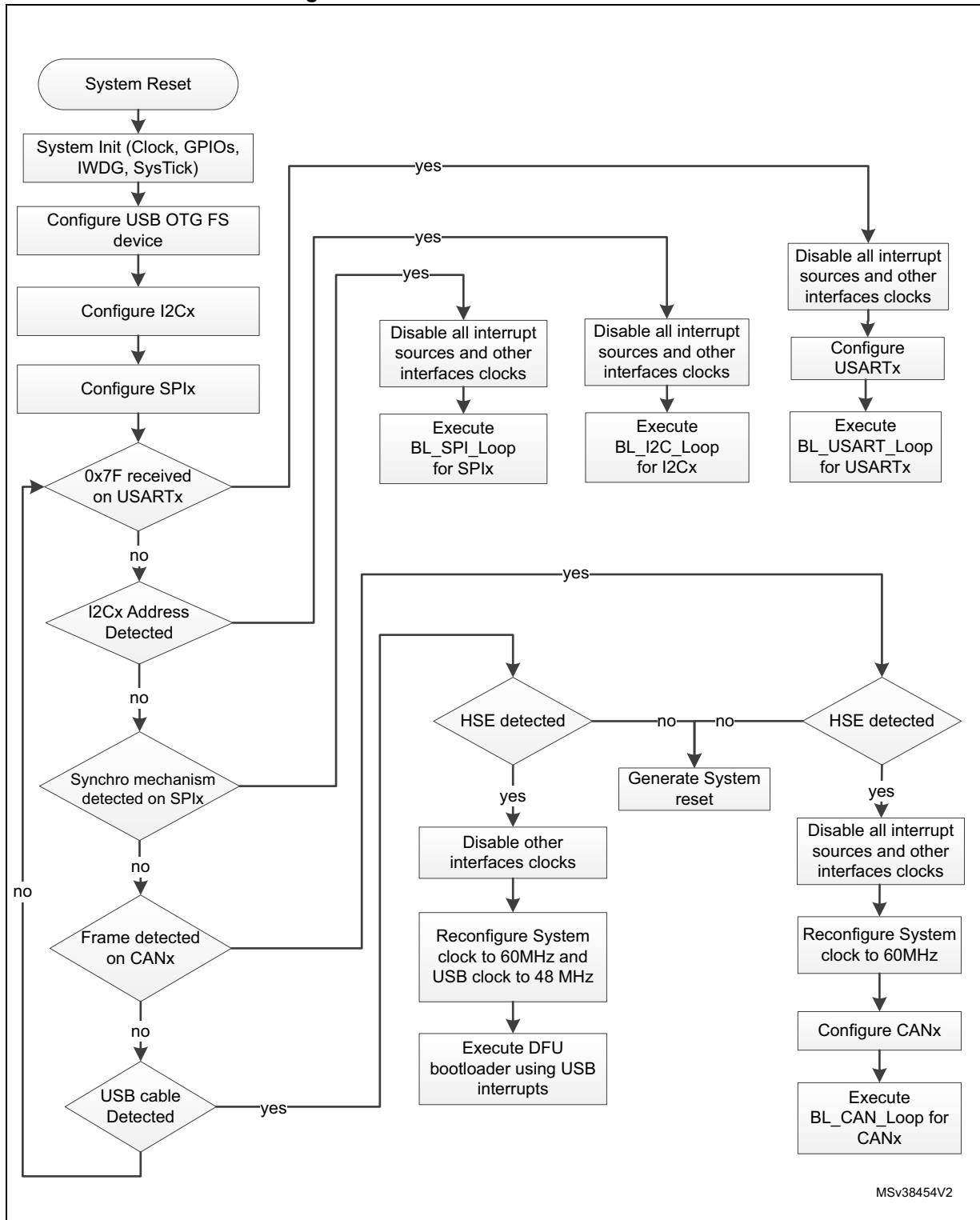

31.3 Bootloader version

The following table lists the STM32F412xx devices bootloader V9.x versions.

Table 66. STM32F412xx bootloader V9.x versions

Bootloader version number	Description	Known limitations
V9.0	Initial bootloader version	After executing Go command (jump to user code) the bootloader resets AHB1ENR value to 0x0000 0000 and thus CCM RAM, when present, is not active (must be re-enabled by user code at startup)
V9.1	Fix USART3 interface pinout	After executing Go command (jump to user code) the bootloader resets AHB1ENR value to 0x0000 0000 and thus CCM RAM, when present, is not active (must be re-enabled by user code at startup)

32 STM32F413xx/423xx devices bootloader

32.1 Bootloader configuration

The STM32F413xx/423xx bootloader is activated by applying Pattern 1 (described in [Table 2: Bootloader activation patterns](#)). The following table shows the hardware resources used by this bootloader.

Table 67. STM32F413xx/423xx configuration in system memory boot mode

Bootloader	Feature/Peripheral	State	Comment
Common to all bootloaders	RCC	HSI enabled	The HSI is used at startup as clock source for system clock configured to 60 MHz and for USART and I2C bootloader operation.
		HSE enabled	The HSE is used only when the CAN or the DFU (USB FS Device) interfaces are selected. In this case the system clock configured to 60 MHz with HSE as clock source. The HSE frequency must be multiple of 1 MHz and ranging from 4 MHz to 26 MHz.
		-	The Clock Security System (CSS) interrupt is enabled for the CAN and DFU bootloaders. Any failure (or removal) of the external clock generates system reset.
	RAM	-	16 Kbyte starting from address 0x20000000 are used by the bootloader firmware
	System memory	-	60 Kbyte starting from address 0x1FF00000, contain the bootloader firmware
	IWDG	-	The independent watchdog (IWDG) prescaler is configured to its maximum value. It is periodically refreshed to prevent watchdog reset (in case the hardware IWDG option was previously enabled by the user).
	Power	-	The voltage range is [1.8V, 3.6V] In this range: <ul style="list-style-type: none"> – Flash wait states 4. – System clock frequency 60 MHz. – ART Accelerator enabled. – Flash write operation by byte (refer to Bootloader memory management for more information).

Table 67. STM32F413xx/423xx configuration in system memory boot mode (continued)

Bootloader	Feature/Peripheral	State	Comment
USART1 bootloader	USART1	Enabled	Once initialized the USART1 configuration is: 8-bit, even parity and 1 Stop bit
	USART1_RX pin	Input	PA10 pin: USART1 in reception mode
	USART1_TX pin	Output	PA9 pin: USART1 in transmission mode
USART2 bootloader	USART2	Enabled	Once initialized the USART2 configuration is: 8-bit, even parity and 1 Stop bit
	USART2_RX pin	Input	PD6 pin: USART2 in reception mode
	USART2_TX pin	Output	PD5 pin: USART2 in transmission mode
USART3 bootloader	USART3	Enabled	Once initialized the USART3 configuration is: 8-bit, even parity and 1 Stop bit
	USART3_RX pin	Input	PB11 pin: USART3 in reception mode
	USART3_TX pin	Output	PB10 pin: USART3 in transmission mode
USARTx bootloaders	SysTick timer	Enabled	Used to automatically detect the serial baud rate from the host for USARTx bootloaders.
CAN2 bootloader	CAN2	Enabled	Once initialized the CAN2 configuration is: Baudrate 125 kbps, 11-bit identifier. Note: CAN1 is clocked during CAN2 bootloader execution because CAN1 manages the communication between CAN2 and SRAM.
	CAN2_RX pin	Input	PB5 pin: CAN2 in reception mode
	CAN2_TX pin	Output	PB13 pin: CAN2 in transmission mode
I2C1 bootloader	I2C1	Enabled	The I2C1 configuration is: I2C speed: up to 400 kHz, 7-bit address, slave mode, analog filter ON. Slave 7-bit address: 0b1001011x (where x = 0 for write and x = 1 for read)
	I2C1_SCL pin	Input/Output	PB6 pin: clock line is used in open-drain mode.
	I2C1_SDA pin	Input/Output	PB7 pin: data line is used in open-drain mode.

Table 67. STM32F413xx/423xx configuration in system memory boot mode (continued)

Bootloader	Feature/Peripheral	State	Comment
I2C2 bootloader	I2C2	Enabled	The I2C2 configuration is: I2C speed: up to 400 kHz, 7-bit address, slave mode, analog filter ON. Slave 7-bit address: 0b1001011x (where x = 0 for write and x = 1 for read)
	I2C2_SCL pin	Input/Output	PF1 pin: clock line is used in open-drain mode.
	I2C2_SDA pin	Input/Output	PF0 pin: data line is used in open-drain mode.
I2C3 bootloader	I2C3	Enabled	The I2C3 configuration is: I2C speed: up to 400 kHz, 7-bit address, slave mode, analog filter ON. Slave 7-bit address: 0b1001011x (where x = 0 for write and x = 1 for read)
	I2C3_SCL pin	Input/Output	PA8 pin: clock line is used in open-drain mode.
	I2C3_SDA pin	Input/Output	PB4 pin: data line is used in open-drain mode.
I2C4 bootloader	I2C4	Enabled	The I2C4 configuration is: I2C speed: up to 1 MHz, 7-bit address, slave mode, analog filter ON. Slave 7-bit address: 0b1001011x (where x = 0 for write and x = 1 for read)
	I2C4_SCL pin	Input/Output	PB15 pin: clock line is used in open-drain mode.
	I2C4_SDA pin	Input/Output	PB14 pin: data line is used in open-drain mode.
SPI1 bootloader	SPI1	Enabled	The SPI1 configuration is: – Slave mode – Full Duplex – 8-bit MSB, speed up to 8 MHz – Polarity: CPOL Low, CPHA Low, NSS hardware.
	SPI1_MOSI pin	Input	PA7 pin: Slave data Input line, used in push-pull, pull-down mode
	SPI1_MISO pin	Output	PA6 pin: Slave data output line, used in push-pull, pull-down mode
	SPI1_SCK pin	Input	PA5 pin: Slave clock line, used in push-pull, pull-down mode
	SPI1_NSS pin	Input	PA4 pin: slave chip select pin used in push-pull, pull-down mode.

Table 67. STM32F413xx/423xx configuration in system memory boot mode (continued)

Bootloader	Feature/Peripheral	State	Comment
SPI3 bootloader	SPI3	Enabled	The SPI3 configuration is: – Slave mode – Full Duplex – 8-bit MSB, speed up to 8 MHz – Polarity: CPOL Low, CPHA Low, NSS hardware.
	SPI3_MOSI pin	Input	PC12 pin: Slave data Input line, used in push-pull, pull-down mode
	SPI3_MISO pin	Output	PC11 pin: Slave data output line, used in push-pull, pull-down mode
	SPI3_SCK pin	Input	PC10 pin: Slave clock line, used in push-pull, pull-down mode
	SPI3_NSS pin	Input	PA15 pin: slave chip select pin used in push-pull, pull-down mode.
SPI4 bootloader	SPI4	Enabled	The SPI4 configuration is: – Slave mode – Full Duplex – 8-bit MSB, speed up to 8 MHz – Polarity: CPOL Low, CPHA Low, NSS hardware.
	SPI4_MOSI pin	Input	PE14 pin: Slave data Input line, used in push-pull, pull-down mode
	SPI4_MISO pin	Output	PE13 pin: Slave data output line, used in push-pull, pull-down mode
	SP4_SCK pin	Input	PE12 pin: Slave clock line, used in push-pull, pull-down mode
	SPI4_NSS pin	Input	PE11 pin: slave chip select pin used in push-pull, pull-down mode.
DFU bootloader	USB	Enabled	USB OTG FS configured in forced device mode
	USB_DM pin	Input/Output	PA11 pin: USB DM line.
	USB_DP pin		PA12 pin: USB DP line No external Pull-Up resistor is required.
CAN2 and DFU bootloaders	TIM11	Enabled	This timer is used to determine the value of the HSE. Once HSE frequency is determined, the system clock is configured to 60 MHz using PLL and HSE.

The system clock is derived from the embedded internal high-speed RC for USARTx and I2Cx bootloaders. This internal clock is also used for CAN and DFU (USB FS Device) but only for the selection phase. An external clock multiple of 1 MHz (between 4 and 26 MHz) is required for CAN and DFU bootloader execution after the selection phase.

Note: Due to HSI deviation and since HSI is used to detect HSE value, the user must use low frequency rather than high frequency HSE crystal values (low frequency values are better detected due to larger error margin). For example, it is better to use 8 MHz instead of 25 MHz.

32.2 Bootloader selection

Figure 37 shows the bootloader selection mechanism.

Figure 37.Bootloader V9.x selection for STM32F413xx/423xx

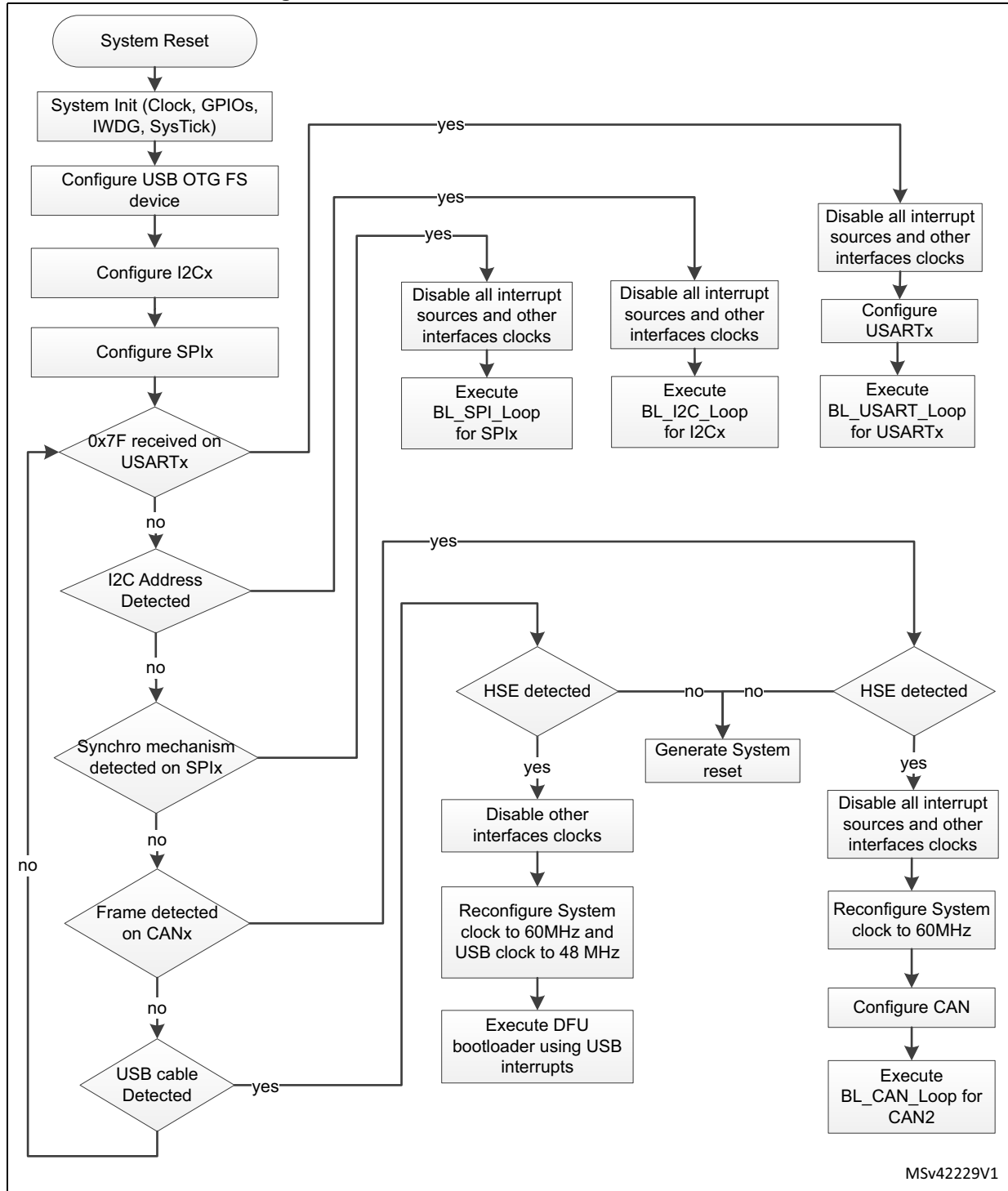

32.3 Bootloader version

The following table lists the STM32F413xx/423xx devices bootloader V9.x versions.

Table 68. STM32F413xx/423xx bootloader V9.x versions

Bootloader version number	Description	Known limitations
V9.0	Initial bootloader version	After executing Go command (jump to user code) the bootloader resets AHB1ENR value to 0x0000 0000 and thus CCM RAM, when present, is not active (must be re-enabled by user code at startup)

33 STM32F42xxx/43xxx devices bootloader

33.1 Bootloader V7.x

33.1.1 Bootloader configuration

The STM32F42xxx/43xxx bootloader is activated by applying Pattern 5 (described in [Table 2: Bootloader activation patterns](#)). The following table shows the hardware resources used by this bootloader.

Table 69. STM32F42xxx/43xxx configuration in system memory boot mode

Bootloader	Feature/Peripheral	State	Comment
Common to all bootloaders	RCC	HSI enabled	The system clock frequency is 24 MHz using the PLL. The HSI clock source is used at startup (interface detection phase) and when USART or I2C interfaces are selected (once CAN or DFU bootloader is selected, the clock source is derived from the external crystal).
		HSE enabled	The system clock frequency is 60 MHz. The HSE clock source is used only when the CAN or the DFU (USB FS Device) interfaces are selected. The external clock must provide a frequency multiple of 1 MHz and ranging from 4 MHz to 26 MHz.
		-	The Clock Security System (CSS) interrupt is enabled for the CAN and DFU bootloaders. Any failure (or removal) of the external clock generates system reset.
	RAM	-	8 Kbyte starting from address 0x20000000 are used by the bootloader firmware
	System memory	-	29 Kbyte starting from address 0x1FFF0000, contain the bootloader firmware
	IWDG	-	The independent watchdog (IWDG) prescaler is configured to its maximum value. It is periodically refreshed to prevent watchdog reset (in case the hardware IWDG option was previously enabled by the user).
	Power	-	Voltage range is set to [1.62 V, 2.1 V]. In this range internal Flash write operations are allowed only in byte format (Half-Word, Word and Double-Word operations are not allowed). The voltage range can be configured in run time using bootloader commands.

Table 69. STM32F42xxx/43xxx configuration in system memory boot mode (continued)

Bootloader	Feature/Peripheral	State	Comment
USART1 bootloader	USART1	Enabled	Once initialized the USART1 configuration is: 8 bits, even parity and 1 Stop bit
	USART1_RX pin	Input	PA10 pin: USART1 in reception mode
	USART1_TX pin	Output	PA9 pin: USART1 in transmission mode
USART3 bootloader (on PB10/PB11)	USART3	Enabled	Once initialized the USART3 configuration is: 8 bits, even parity and 1 Stop bit
	USART3_RX pin	Input	PB11 pin: USART3 in reception mode
	USART3_TX pin	Output	PB10 pin: USART3 in transmission mode
USART3 bootloader (on PC10/PC11)	USART3	Enabled	Once initialized the USART3 configuration is: 8 bits, even parity and 1 Stop bit
	USART3_RX pin	Input	PC11 pin: USART3 in reception mode
	USART3_TX pin	Output	PC10 pin: USART3 in transmission mode
USARTx bootloaders	SysTick timer	Enabled	Used to automatically detect the serial baud rate from the host for USARTx bootloaders.
CAN2 bootloader	CAN2	Enabled	Once initialized the CAN2 configuration is: Baudrate 125 kbps, 11-bit identifier. Note: CAN1 is clocked during CAN2 bootloader execution because CAN1 manages the communication between CAN2 and SRAM.
	CAN2_RX pin	Input	PB5 pin: CAN2 in reception mode
	CAN2_TX pin	Output	PB13 pin: CAN2 in transmission mode
I2C1 bootloader	I2C1	Enabled	The I2C1 configuration is: I2C speed: up to 400 kHz, 7-bit address, slave mode, analog filter ON. Slave 7-bit address: 0b0111000x (where x = 0 for write and x = 1 for read).
	I2C1_SCL pin	Input/Output	PB6 pin: clock line is used in open-drain mode.
	I2C1_SDA pin	Input/Output	PB9 pin: data line is used in open-drain mode.
DFU bootloader	USB	Enabled	USB OTG FS configured in forced device mode
	USB_DM pin	Input/Output	PA11: USB DM line.
	USB_DP pin		PA12: USB DP line No external pull-up resistor is required
CAN2 and DFU bootloaders	TIM11	Enabled	This timer is used to determine the value of the HSE. Once the HSE frequency is determined, the system clock is configured to 60 MHz using PLL and HSE.

The system clock is derived from the embedded internal high-speed RC for USARTx and I2Cx bootloaders. This internal clock is also used for CAN and DFU (USB FS Device) but only for the selection phase. An external clock multiple of 1 MHz (between 4 and 26 MHz) is required for CAN and DFU bootloader execution after the selection phase.

Note: Due to HSI deviation and since HSI is used to detect HSE value, the user must use low frequency rather than high frequency HSE crystal values (low frequency values are better detected due to larger error margin). For example, it is better to use 8 MHz instead of 25 MHz.

33.1.2 Bootloader selection

Figure 38 and Figure 39 show the bootloader selection mechanism.

Figure 38. Dual bank boot implementation for STM32F42xxx/43xxx Bootloader V7.x

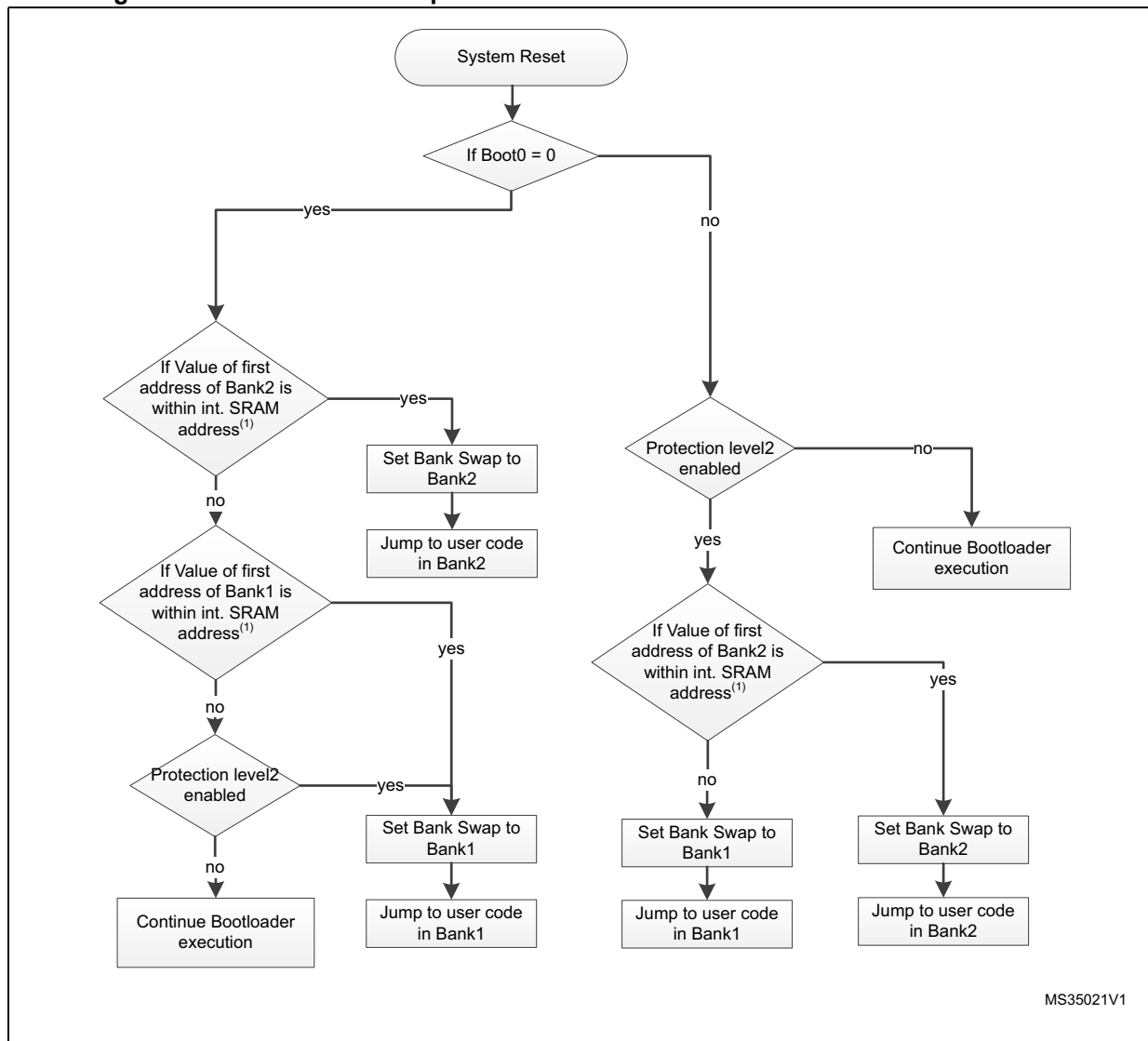

1. CCM RAM is not considered valid as stack pointer address for the dual bank boot mechanism.

Figure 39. Bootloader V7.x selection for STM32F42xxx/43xxx

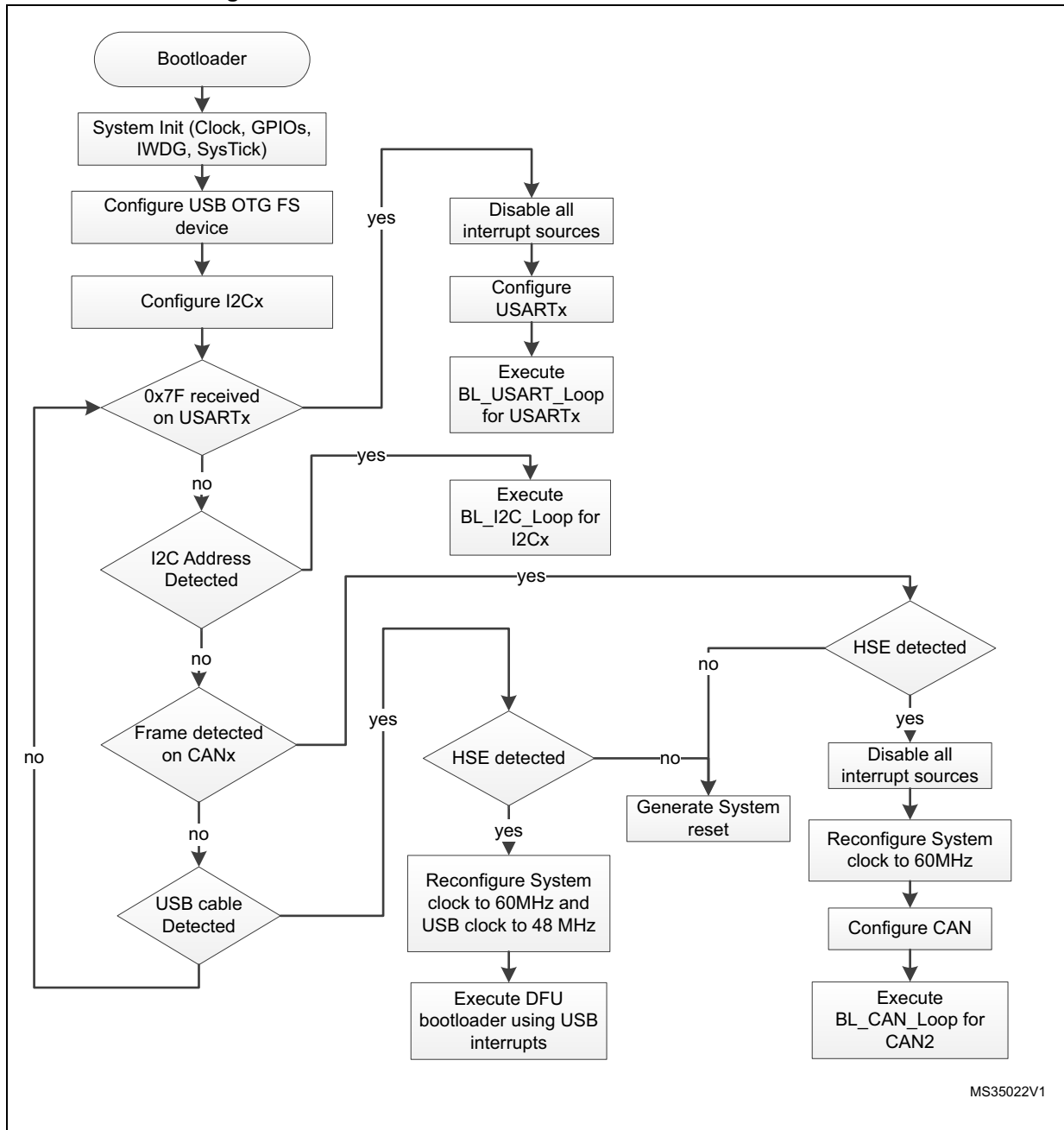

33.1.3 Bootloader version

The following table lists the STM32F42xxx/43xxx devices bootloader V7.x versions.

Table 70. STM32F42xxx/43xxx bootloader V7.x versions

Bootloader version number	Description	Known limitations
V7.0	Initial bootloader version	<p>For the CAN interface, the Write Unprotect command is not functional. Use Write Memory command and write directly to the option bytes to disable the write protection.</p> <p>For the USB DFU interface, in Dual Bank mode, the Erase operation is not functional for the second bank. Return to Single Bank mode, erase desired sector(s) and then reactivate the Dual Bank mode.</p> <p>After executing Go command (jump to user code) the bootloader resets AHB1ENR value to 0x0000 0000 and thus CCM RAM, when present, is not active (must be re-enabled by user code at startup).</p>

33.2 Bootloader V9.x

33.2.1 Bootloader configuration

The STM32F42xxx/43xxx bootloader is activated by applying Pattern 5 (described in [Table 2: Bootloader activation patterns](#)). The following table shows the hardware resources used by this bootloader.

Table 71. STM32F42xxx/43xxx configuration in system memory boot mode

Bootloader	Feature/Peripheral	State	Comment
Common to all bootloaders	RCC	HSI enabled	The system clock frequency is 60 MHz using the PLL. The HSI clock source is used at startup (interface detection phase) and when USART or SPI or I2C interfaces are selected (once CAN or DFU bootloader is selected, the clock source is derived from the external crystal).
		HSE enabled	The system clock frequency is 60 MHz. The HSE clock source is used only when the CAN or the DFU (USB FS Device) interfaces are selected. The external clock must provide a frequency multiple of 1 MHz and ranging from 4 MHz to 26 MHz.
		-	The Clock Security System (CSS) interrupt is enabled for the CAN and DFU bootloaders. Any failure (or removal) of the external clock generates system reset.
	RAM	-	12 Kbyte starting from address 0x20000000 are used by the bootloader firmware
	System memory	-	29 Kbyte starting from address 0x1FFF0000, contain the bootloader firmware
	IWDG	-	The independent watchdog (IWDG) prescaler is configured to its maximum value. It is periodically refreshed to prevent watchdog reset (in case the hardware IWDG option was previously enabled by the user).
	Power	-	Voltage range is set to [1.62 V, 2.1 V]. In this range internal Flash write operations are allowed only in byte format (Half-Word, Word and Double-Word operations are not allowed). The voltage range can be configured in run time using bootloader commands.
USART1 bootloader	USART1	Enabled	Once initialized the USART1 configuration is: 8-bit, even parity and 1 Stop bit
	USART1_RX pin	Input	PA10 pin: USART1 in reception mode
	USART1_TX pin	Output	PA9 pin: USART1 in transmission mode

Table 71. STM32F42xxx/43xxx configuration in system memory boot mode (continued)

Bootloader	Feature/Peripheral	State	Comment
USART3 bootloader (on PB10/PB11)	USART3	Enabled	Once initialized the USART3 configuration is: 8-bit, even parity and 1 Stop bit
	USART3_RX pin	Input	PB11 pin: USART3 in reception mode
	USART3_TX pin	Output	PB10 pin: USART3 in transmission mode
USART3 bootloader (on PC10/PC11)	USART3	Enabled	Once initialized the USART3 configuration is: 8-bit, even parity and 1 Stop bit
	USART3_RX pin	Input	PC11 pin: USART3 in reception mode
	USART3_TX pin	Output	PC10 pin: USART3 in transmission mode
USARTx bootloaders	SysTick timer	Enabled	Used to automatically detect the serial baud rate from the host for USARTx bootloaders.
CAN2 bootloader	CAN2	Enabled	Once initialized the CAN2 configuration is: Baudrate 125 kbps, 11-bit identifier. Note: CAN1 is clocked during CAN2 bootloader execution because CAN1 manages the communication between CAN2 and SRAM.
	CAN2_RX pin	Input	PB5 pin: CAN2 in reception mode
	CAN2_TX pin	Output	PB13 pin: CAN2 in transmission mode
I2C1 bootloader	I2C1	Enabled	The I2C1 configuration is: I2C speed: up to 400 kHz, 7-bit address, slave mode, analog filter ON. Slave 7-bit address: 0b0111000x (where x = 0 for write and x = 1 for read).
	I2C1_SCL pin	Input/Output	PB6 pin: clock line is used in open-drain mode.
	I2C1_SDA pin	Input/Output	PB9 pin: data line is used in open-drain mode.
I2C2 bootloader	I2C2	Enabled	The I2C2 configuration is: I2C speed: up to 400 kHz, 7-bit address, slave mode, analog filter ON. Slave 7-bit address: 0b0111000x (where x = 0 for write and x = 1 for read).
	I2C2_SCL pin	Input/Output	PF1 pin: clock line is used in open-drain mode.
	I2C2_SDA pin	Input/Output	PF0 pin: data line is used in open-drain mode.
I2C3 bootloader	I2C3	Enabled	The I2C3 configuration is: I2C speed: up to 400 kHz, 7-bit address, slave mode, analog filter ON. Slave 7-bit address: 0b0111000x (where x = 0 for write and x = 1 for read).
	I2C3_SCL pin	Input/Output	PA8 pin: clock line is used in open-drain mode.
	I2C3_SDA pin	Input/Output	PC9 pin: data line is used in open-drain mode.

Table 71. STM32F42xxx/43xxx configuration in system memory boot mode (continued)

Bootloader	Feature/Peripheral	State	Comment
SPI1 bootloader	SPI1	Enabled	The SPI1 configuration is: Slave mode, Full Duplex, -bit MSB, Speed up to 8 MHz, Polarity: CPOL Low, CPHA Low, NSS hardware.
	SPI1_MOSI pin	Input	PA7 pin: Slave data Input line, used in push-pull, pull-down mode
	SPI1_MISO pin	Output	PA6 pin: Slave data output line, used in push-pull, pull-down mode
	SPI1_SCK pin	Input	PA5 pin: Slave clock line, used in push-pull, pull-down mode
	SPI1_NSS pin	Input	PA4 pin: slave chip select pin used in push-pull, pull-down mode.
SPI2 bootloader	SPI2	Enabled	The SPI2 configuration is: Slave mode, Full Duplex, 8-bit MSB, Speed up to 8 MHz, Polarity: CPOL Low, CPHA Low, NSS hardware.
	SPI2_MOSI pin	Input	PI3 pin: Slave data Input line, used in push-pull, pull-down mode
	SPI2_MISO pin	Output	PI2 pin: Slave data output line, used in push-pull, pull-down mode
	SPI2_SCK pin	Input	PI1 pin: Slave clock line, used in push-pull, pull-down mode
	SPI2_NSS pin	Input	PI0 pin: slave chip select pin used in push-pull, pull-down mode.
SPI4 bootloader	SPI4	Enabled	The SPI4 configuration is: Slave mode, Full Duplex, 8-bit MSB, Speed up to 8 MHz, Polarity: CPOL Low, CPHA Low, NSS hardware.
	SPI4_MOSI pin	Input	PE14 pin: Slave data Input line, used in push-pull, pull-down mode
	SPI4_MISO pin	Output	PE13 pin: Slave data output line, used in push-pull, pull-down mode
	SP4_SCK pin	Input	PE12 pin: Slave clock line, used in push-pull, pull-down mode
	SPI4_NSS pin	Input	PE11 pin: slave chip select pin used in push-pull, pull-down mode.
DFU bootloader	USB	Enabled	USB OTG FS configured in forced device mode
	USB_DM pin	Input/Output	PA11: USB DM line.
	USB_DP pin		PA12: USB DP line No external pull-up resistor is required
CAN2 and DFU bootloaders	TIM11	Enabled	This timer is used to determine the value of the HSE. Once the HSE frequency is determined, the system clock is configured to 60 MHz using PLL and HSE.

The system clock is derived from the embedded internal high-speed RC for USARTx, I2Cx and SPIx bootloaders. This internal clock is also used for CAN and DFU (USB FS Device) but only for the selection phase. An external clock multiple of 1 MHz (between 4 and 26 MHz) is required for CAN and DFU bootloader execution after the selection phase.

Note: Due to HSI deviation and since HSI is used to detect HSE value, the user must use low frequency rather than high frequency HSE crystal values (low frequency values are better detected due to larger error margin). For example, it is better to use 8 MHz instead of 25 MHz.

33.2.2 Bootloader selection

Figure 40 and Figure 41 show the bootloader selection mechanism.

Figure 40. Dual bank boot implementation for STM32F42xxx/43xxx bootloader V9.x

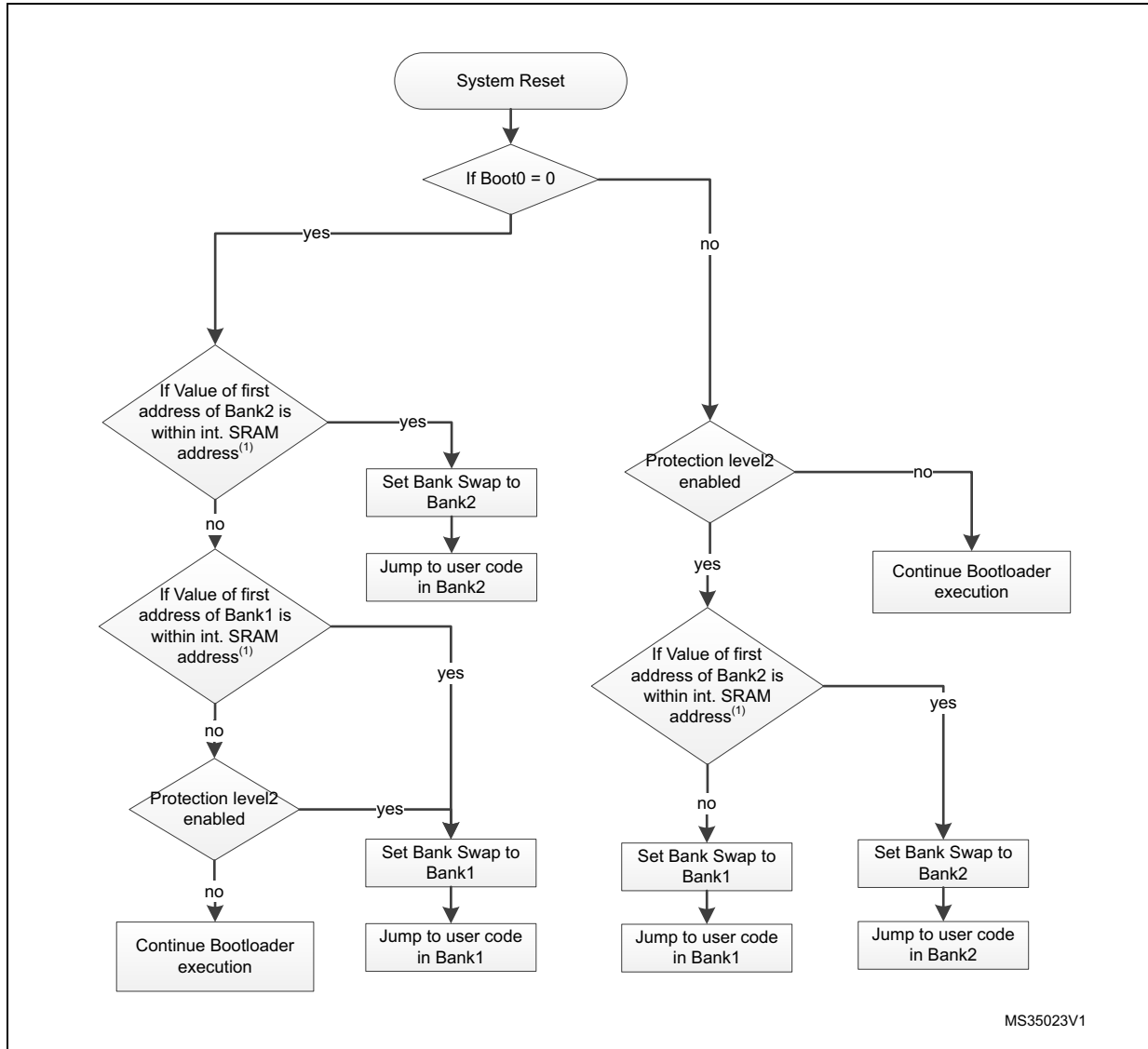

1. CCM RAM is not considered valid as stack pointer address for the dual bank boot mechanism.

Figure 41. Bootloader V9.x selection for STM32F42xxx/43xxx

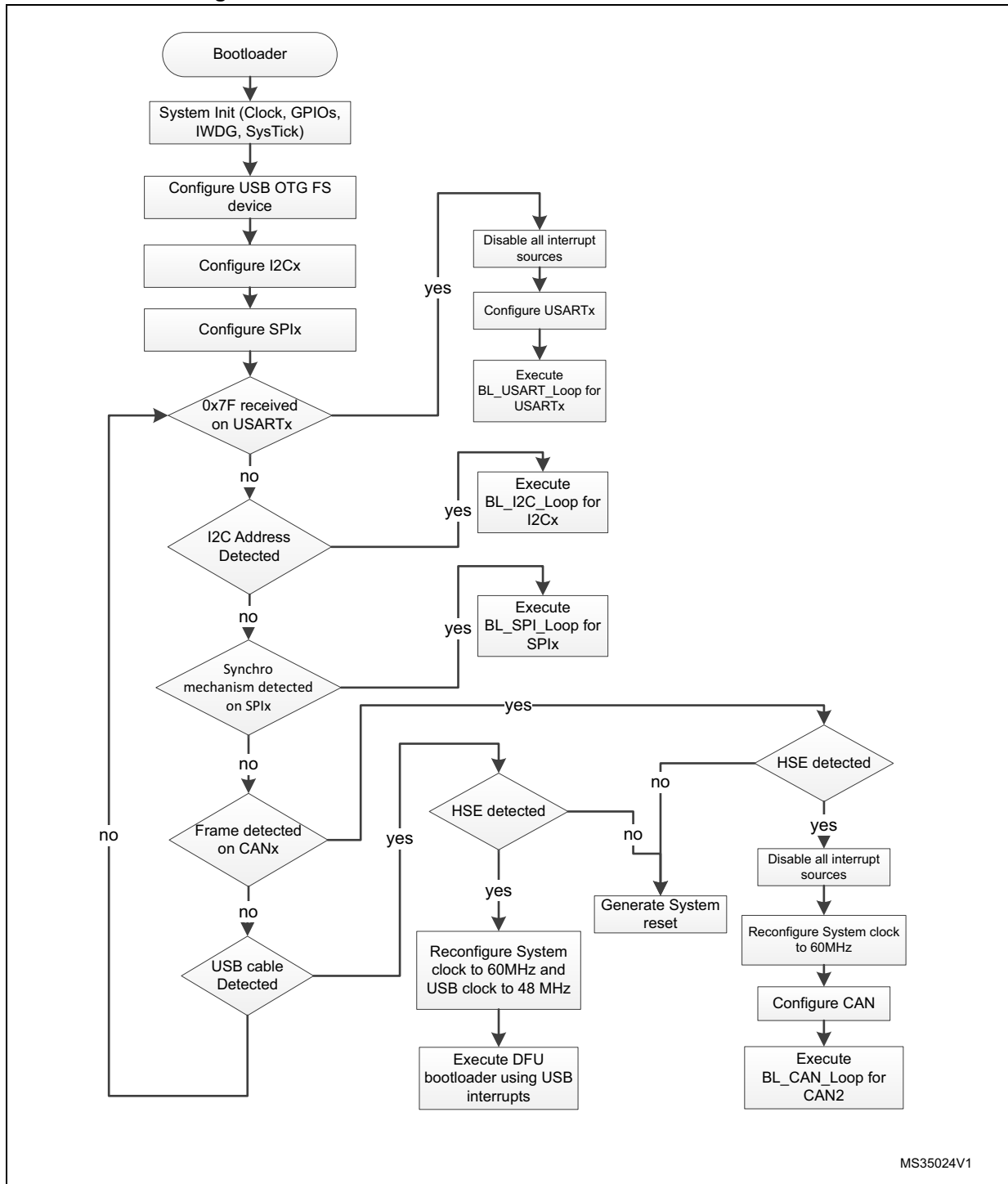

MS35024V1

33.2.3 Bootloader version

[Table 72](#) lists the STM32F42xxx/43xxx devices bootloader V9.x versions.

Table 72. STM32F42xxx/43xxx bootloader V9.x versions

Bootloader version number	Description	Known limitations
V9.0	<p>This bootloader is an updated version of bootloader v7.0. This new version of bootloader supports I2C2, I2C3, SPI1, SPI2 and SPI4 interfaces.</p> <p>The RAM used by this bootloader is increased from 8 Kb to 12 Kb.</p> <p>The ID of this bootloader is 0x90</p> <p>The connection time is increased.</p>	<p>For the USB DFU interface, in Dual Bank mode, the Erase operation is not functional for the second bank. Return to Single Bank mode, erase desired sector(s) and then reactivate the Dual Bank mode.</p> <p>After executing Go command (jump to user code) the bootloader resets AHB1ENR value to 0x0000 0000 and thus CCM RAM, when present, is not active (must be re-enabled by user code at startup)</p>
V9.1	<p>This bootloader is an updated version of bootloader v9.0. This new version implements the new I2C No-stretch commands (I2C protocol v1.1) and the capability of disabling PcROP when RDP1 is enabled with ReadOutUnprotect command for all protocols(USB, USART, CAN, I2C and SPI). The ID of this bootloader is 0x91</p>	<p>For the CAN interface, the Write Unprotect command is not functional. Use Write Memory command and write directly to the option bytes in order to disable the write protection.</p> <p>For the USB DFU interface, in Dual Bank mode, the Erase operation is not functional for the second bank. Return to Single Bank mode, erase desired sector(s) and then reactivate the Dual Bank mode.</p> <p>After executing Go command (jump to user code) the bootloader resets AHB1ENR value to 0x0000 0000 and thus CCM RAM, when present, is not active (must be re-enabled by user code at startup)</p>

34 STM32F446xx devices bootloader

34.1 Bootloader configuration

The STM32F446xx bootloader is activated by applying Pattern 1 (described in [Table 2: Bootloader activation patterns](#)). The following table shows the hardware resources used by this bootloader.

Table 73. STM32F446xx configuration in system memory boot mode

Bootloader	Feature/Peripheral	State	Comment
Common to all bootloaders	RCC	HSI enabled	The HSI is used at startup as clock source for system clock configured to 60 MHz and for USART, I2C and SPI bootloader operation.
		HSE enabled	The HSE is used only when the CAN or the DFU (USB FS Device) interfaces are selected. In this case the system clock configured to 60 MHz with HSE as clock source. The HSE frequency must be multiple of 1 MHz and ranging from 4 MHz to 26 MHz.
		-	The Clock Security System (CSS) interrupt is enabled for the CAN and DFU bootloaders. Any failure (or removal) of the external clock generates system reset.
	RAM	-	12 Kbyte starting from address 0x20000000 are used by the bootloader firmware
	System memory	-	29 Kbyte starting from address 0x1FFF0000, contain the bootloader firmware
	IWDG	-	The independent watchdog (IWDG) prescaler is configured to its maximum value. It is periodically refreshed to prevent watchdog reset (in case the hardware IWDG option was previously enabled by the user).
	Power	-	The voltage range is [1.71 V, 3.6 V]. In this range: - Flash wait states: 3. - System Clock 60 MHz. - Prefetch disabled. - Flash write operation by byte (refer to section bootloader memory management for more information).

Table 73. STM32F446xx configuration in system memory boot mode (continued)

Bootloader	Feature/Peripheral	State	Comment
USART1 bootloader	USART1	Enabled	Once initialized the USART1 configuration is: 8-bit, even parity and 1 Stop bit
	USART1_RX pin	Input	PA10 pin: USART1 in reception mode
	USART1_TX pin	Output	PA9 pin: USART1 in transmission mode
USART3 bootloader (on PB10/PB11)	USART3	Enabled	Once initialized the USART3 configuration is: 8-bit, even parity and 1 Stop bit
	USART3_RX pin	Input	PB11 pin: USART3 in reception mode
	USART3_TX pin	Output	PB10 pin: USART3 in transmission mode
USART3 bootloader (on PC10/PC11)	USART3	Enabled	Once initialized the USART3 configuration is: 8-bit, even parity and 1 Stop bit
	USART3_RX pin	Input	PC11 pin: USART3 in reception mode
	USART3_TX pin	Output	PC10 pin: USART3 in transmission mode
USARTx bootloaders	SysTick timer	Enabled	Used to automatically detect the serial baud rate from the host for USARTx bootloaders.
CAN2 bootloader	CAN2	Enabled	Once initialized the CAN2 configuration is: Baudrate 125 kbps, 11-bit identifier. Note: CAN1 is clocked during CAN2 bootloader execution because in CAN1 manages the communication between CAN2 and SRAM.
	CAN2_RX pin	Input	PB5 pin: CAN2 in reception mode
	CAN2_TX pin	Output	PB13 pin: CAN2 in transmission mode
I2C1 bootloader	I2C1	Enabled	The I2C1 configuration is: I2C speed: up to 400 kHz, 7-bit address, slave mode, analog filter ON. Slave 7-bit address: 0b0111100x (where x = 0 for write and x = 1 for read)
	I2C1_SCL pin	Input/Output	PB6 pin: clock line is used in open-drain mode.
	I2C1_SDA pin	Input/Output	PB9 pin: data line is used in open-drain mode.
I2C2 bootloader	I2C2	Enabled	The I2C2 configuration is: I2C speed: up to 400 kHz, 7-bit address, slave mode, analog filter ON. Slave 7-bit address: 0b0111100x (where x = 0 for write and x = 1 for read)
	I2C2_SCL pin	Input/Output	PF1 pin: clock line is used in open-drain mode.
	I2C2_SDA pin	Input/Output	PF0 pin: data line is used in open-drain mode.

Table 73. STM32F446xx configuration in system memory boot mode (continued)

Bootloader	Feature/Peripheral	State	Comment
I2C3 bootloader	I2C3	Enabled	The I2C3 configuration is: I2C speed: up to 400 kHz, 7-bit address, slave mode, analog filter ON. Slave 7-bit address: 0b0111100x (where x = 0 for write and x = 1 for read)
	I2C3_SCL pin	Input/Output	PA8 pin: clock line is used in open-drain mode.
	I2C3_SDA pin	Input/Output	PC9 pin: data line is used in open-drain mode.
SPI1 bootloader	SPI1	Enabled	The SPI1 configuration is: Slave mode, Full Duplex, 8-bit MSB, Speed up to 8 MHz, Polarity: CPOL Low, CPHA Low, NSS hardware.
	SPI1_MOSI pin	Input	PA7 pin: Slave data Input line, used in push-pull, pull-down mode
	SPI1_MISO pin	Output	PA6 pin: Slave data output line, used in push-pull, pull-down mode
	SPI1_SCK pin	Input	PA5 pin: Slave clock line, used in push-pull, pull-down mode
	SPI1_NSS pin	Input	PA4 pin: slave chip select pin used in push-pull, pull-down mode.
SPI2 bootloader	SPI2	Enabled	The SPI2 configuration is: Slave mode, Full Duplex, 8-bit MSB, Speed up to 8 MHz, Polarity: CPOL Low, CPHA Low, NSS hardware.
	SPI2_MOSI pin	Input	PB15 pin: Slave data Input line, used in push-pull, pull-down mode
	SPI2_MISO pin	Output	PB14 pin: Slave data output line, used in push-pull, pull-down mode
	SPI2_SCK pin	Input	PC7 pin: Slave clock line, used in push-pull, pull-down mode
	SPI2_NSS pin	Input	PB12 pin: slave chip select pin used in push-pull, pull-down mode.

Table 73. STM32F446xx configuration in system memory boot mode (continued)

Bootloader	Feature/Peripheral	State	Comment
SPI4 bootloader	SPI4	Enabled	The SPI4 configuration is: Slave mode, Full Duplex, 8-bit MSB, Speed up to 8 MHz, Polarity: CPOL Low, CPHA Low, NSS hardware.
	SPI4_MOSI pin	Input	PE14 pin: Slave data Input line, used in push-pull, pull-down mode
	SPI4_MISO pin	Output	PE13 pin: Slave data output line, used in push-pull, pull-down mode
	SPI4_SCK pin	Input	PE12 pin: Slave clock line, used in push-pull, pull-down mode
	SPI4_NSS pin	Input	PE11 pin: slave chip select pin used in push-pull, pull-down mode.
DFU bootloader	USB	Enabled	USB OTG FS configured in forced device mode
	USB_DM pin	Input/Output	PA11: USB DM line.
	USB_DP pin		PA12: USB DP line No external pull-up resistor is required
CAN2 and DFU bootloaders	TIM17	Enabled	This timer is used to determine the value of the HSE. Once the HSE frequency is determined, the system clock is configured to 60 MHz using PLL and HSE.

The system clock is derived from the embedded internal high-speed RC for USARTx and I2Cx bootloaders. This internal clock is also used for CAN and DFU (USB FS Device) but only for the selection phase. An external clock multiple of 1 MHz (between 4 and 26 MHz) is required for CAN and DFU bootloader execution after the selection phase.

Note: Due to HSI deviation and since HSI is used to detect HSE value, the user must use low frequency rather than high frequency HSE crystal values (low frequency values are better detected due to larger error margin). For example, it is better to use 8 MHz instead of 25 MHz.

34.2 Bootloader selection

The figure below shows the bootloader selection mechanism.

Figure 42.Bootloader V9.x selection for STM32F446xx

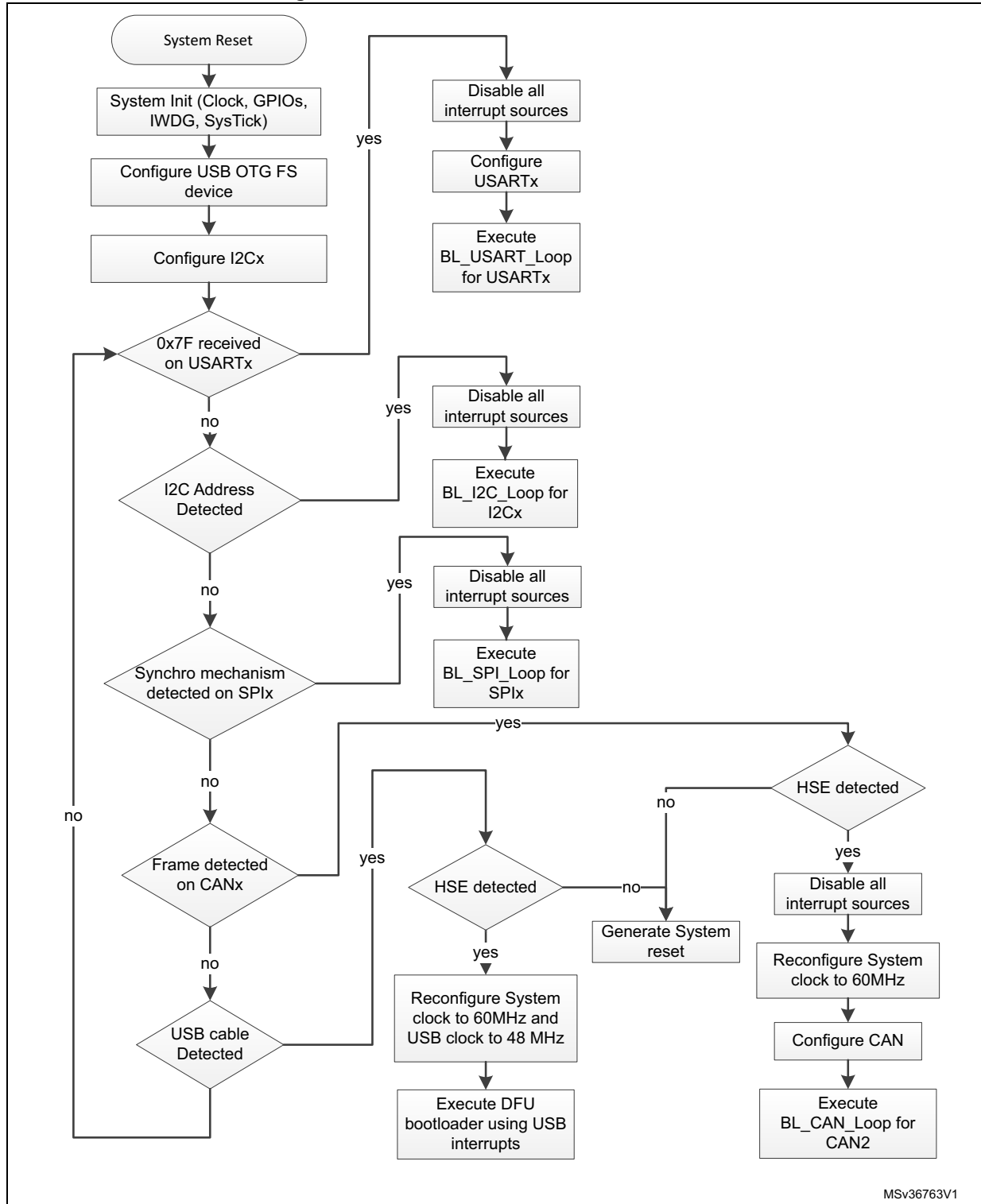

MSv36763V1

34.3 Bootloader version

The following table lists the STM32F446xx devices bootloader V9.x versions:

Table 74. STM32F446xx bootloader V9.x versions

Bootloader version number	Description	Known limitations
V9.0	Initial bootloader version	After executing Go command (jump to user code) the bootloader resets AHB1ENR value to 0x0000 0000 and thus CCM RAM, when present, is not active (must be re-enabled by user code at startup)

35 STM32F469xx/479xx devices bootloader

35.1 Bootloader configuration

The STM32F469xx/479xx bootloader is activated by applying Pattern 5 (described in [Table 2: Bootloader activation patterns](#)). [Table 75](#) shows the hardware resources used by this bootloader.

Table 75. STM32F469xx/479xx configuration in system memory boot mode

Bootloader	Feature/Peripheral	State	Comment
Common to all bootloaders	RCC	HSI enabled	The system clock frequency is 60 MHz using the PLL. The HSI clock source is used at startup (interface detection phase) and when USART or SPI or I2C interfaces are selected (once CAN or DFU bootloader is selected, the clock source is derived from external crystal).
		HSE enabled	The system clock frequency is 60 MHz. The HSE clock source is used only when the CAN or the DFU (USB FS Device) interfaces are selected. The external clock must provide a frequency multiple of 1 MHz and ranging from 4 MHz to 26 MHz.
		-	The Clock Security System (CSS) interrupt is enabled for the CAN and DFU bootloaders. Any failure (or removal) of the external clock generates system reset.
	RAM	-	12 Kbyte starting from address 0x20000000 are used by the bootloader firmware
	System memory	-	29 Kbyte starting from address 0x1FFF0000, contain the bootloader firmware
	IWDG	-	The independent watchdog (IWDG) prescaler is configured to its maximum value. It is periodically refreshed to prevent watchdog reset (in case the hardware IWDG option was previously enabled by the user).
	Power	-	Voltage range is set to [1.62 V, 2.1 V]. In this range internal Flash write operations are allowed only in byte format (Half-Word, Word and Double-Word operations are not allowed). The voltage range can be configured in run time using bootloader commands.

Table 75. STM32F469xx/479xx configuration in system memory boot mode (continued)

Bootloader	Feature/Peripheral	State	Comment
USART1 bootloader	USART1	Enabled	Once initialized the USART1 configuration is: 8-bit, even parity and 1 Stop bit
	USART1_RX pin	Input	PA10 pin: USART1 in reception mode
	USART1_TX pin	Output	PA9 pin: USART1 in transmission mode
USART3 bootloader (on PB10/PB11)	USART3	Enabled	Once initialized the USART3 configuration is: 8-bit, even parity and 1 Stop bit
	USART3_RX pin	Input	PB11 pin: USART3 in reception mode
	USART3_TX pin	Output	PB10 pin: USART3 in transmission mode
USART3 bootloader (on PC10/PC11)	USART3	Enabled	Once initialized the USART3 configuration is: 8-bit, even parity and 1 Stop bit
	USART3_RX pin	Input	PC11 pin: USART3 in reception mode
	USART3_TX pin	Output	PC10 pin: USART3 in transmission mode
USARTx bootloaders	SysTick timer	Enabled	Used to automatically detect the serial baud rate from the host for USARTx bootloaders.
CAN2 bootloader	CAN2	Enabled	Once initialized the CAN2 configuration is: Baudrate 125 kbps, 11-bit identifier. Note: CAN1 is clocked during CAN2 bootloader execution because CAN1 manages the communication between CAN2 and SRAM.
	CAN2_RX pin	Input	PB05 pin: CAN2 in reception mode
	CAN2_TX pin	Output	PB13 pin: CAN2 in transmission mode
I2C1 bootloader	I2C1	Enabled	The I2C1 configuration is: I2C speed: up to 400 kHz, 7-bit address, slave mode, analog filter ON. Slave 7-bit address: 0b1000100x (where x = 0 for write and x = 1 for read).
	I2C1_SCL pin	Input/Output	PB6 pin: clock line is used in open-drain mode.
	I2C1_SDA pin	Input/Output	PB9 pin: data line is used in open-drain mode.
I2C2 bootloader	I2C2	Enabled	The I2C2 configuration is: I2C speed: up to 400 kHz, 7-bit address, slave mode, analog filter ON. Slave 7-bit address: 0b1000100x (where x = 0 for write and x = 1 for read).
	I2C2_SCL pin	Input/Output	PF0 pin: clock line is used in open-drain mode.
	I2C2_SDA pin	Input/Output	PF1 pin: data line is used in open-drain mode.

Table 75. STM32F469xx/479xx configuration in system memory boot mode (continued)

Bootloader	Feature/Peripheral	State	Comment
I2C3 bootloader	I2C3	Enabled	The I2C3 configuration is: I2C speed: up to 400 kHz, 7-bit address, slave mode, analog filter ON. Slave 7-bit address: 0b1000100x (where x = 0 for write and x = 1 for read).
	I2C3_SCL pin	Input/Output	PA8 pin: clock line is used in open-drain mode.
	I2C3_SDA pin	Input/Output	PC9 pin: data line is used in open-drain mode.
SPI1 bootloader	SPI1	Enabled	The SPI1 configuration is: Slave mode, Full Duplex, 8-bit MSB, Speed up to 8 MHz, Polarity: CPOL Low, CPHA Low, NSS hardware.
	SPI1_MOSI pin	Input	PA7 pin: Slave data Input line, used in push-pull, pull-down mode
	SPI1_MISO pin	Output	PA6 pin: Slave data output line, used in push-pull, pull-down mode
	SPI1_SCK pin	Input	PA5 pin: Slave clock line, used in push-pull, pull-down mode
SPI2 bootloader	SPI1_NSS pin	Input	PA4 pin: slave chip select pin used in push-pull, pull-down mode.
	SPI2	Enabled	The SPI2 configuration is: Slave mode, Full Duplex, 8-bit MSB, Speed up to 8 MHz, Polarity: CPOL Low, CPHA Low, NSS hardware.
	SPI2_MOSI pin	Input	PI3 pin: Slave data Input line, used in push-pull, pull-down mode
	SPI2_MISO pin	Output	PI2 pin: Slave data output line, used in push-pull, pull-down mode
	SPI2_SCK pin	Input	PI1 pin: Slave clock line, used in push-pull, pull-down mode
	SPI2_NSS pin	Input	PI0 pin: slave chip select pin used in push-pull, pull-down mode.

Table 75. STM32F469xx/479xx configuration in system memory boot mode (continued)

Bootloader	Feature/Peripheral	State	Comment
SPI4 bootloader	SPI4	Enabled	The SPI4 configuration is: Slave mode, Full Duplex, 8-bit MSB, Speed up to 8 MHz, Polarity: CPOL Low, CPHA Low, NSS hardware.
	SPI4_MOSI pin	Input	PE14 pin: Slave data Input line, used in push-pull, pull-down mode
	SPI4_MISO pin	Output	PE13 pin: Slave data output line, used in push-pull, pull-down mode
	SP4_SCK pin	Input	PE12 pin: Slave clock line, used in push- pull, pull-down mode
	SPI4_NSS pin	Input	PE11 pin: slave chip select pin used in push-pull, pull-down mode.
DFU bootloader	USB	Enabled	USB OTG FS configured in forced device mode. USB_OTG_FS interrupt vector is enabled and used for USB DFU communications.
	USB_DM pin	Input/Output	PA11 pin: USB DM line.
	USB_DP pin		PA12 pin: USB DP line. No external Pull-Up resistor is required.

The system clock is derived from the embedded internal high-speed RC for USARTx and I2Cx bootloaders. This internal clock is also used for CAN and DFU (USB FS Device) but only for the selection phase. An external clock multiple of 1 MHz (between 4 and 48 MHz) is required for CAN and DFU bootloaders execution after the selection phase.

Note: Due to HSI deviation and since HSI is used to detect HSE value, the user must use low frequency rather than high frequency HSE crystal values (low frequency values are better detected due to larger error margin). For example, it is better to use 8 MHz instead of 25 MHz.

35.2 Bootloader selection

Figure 43 and Figure 44 show the bootloader selection mechanism.

Figure 43. Dual bank boot implementation for STM32F469xx/479xx Bootloader V9.x

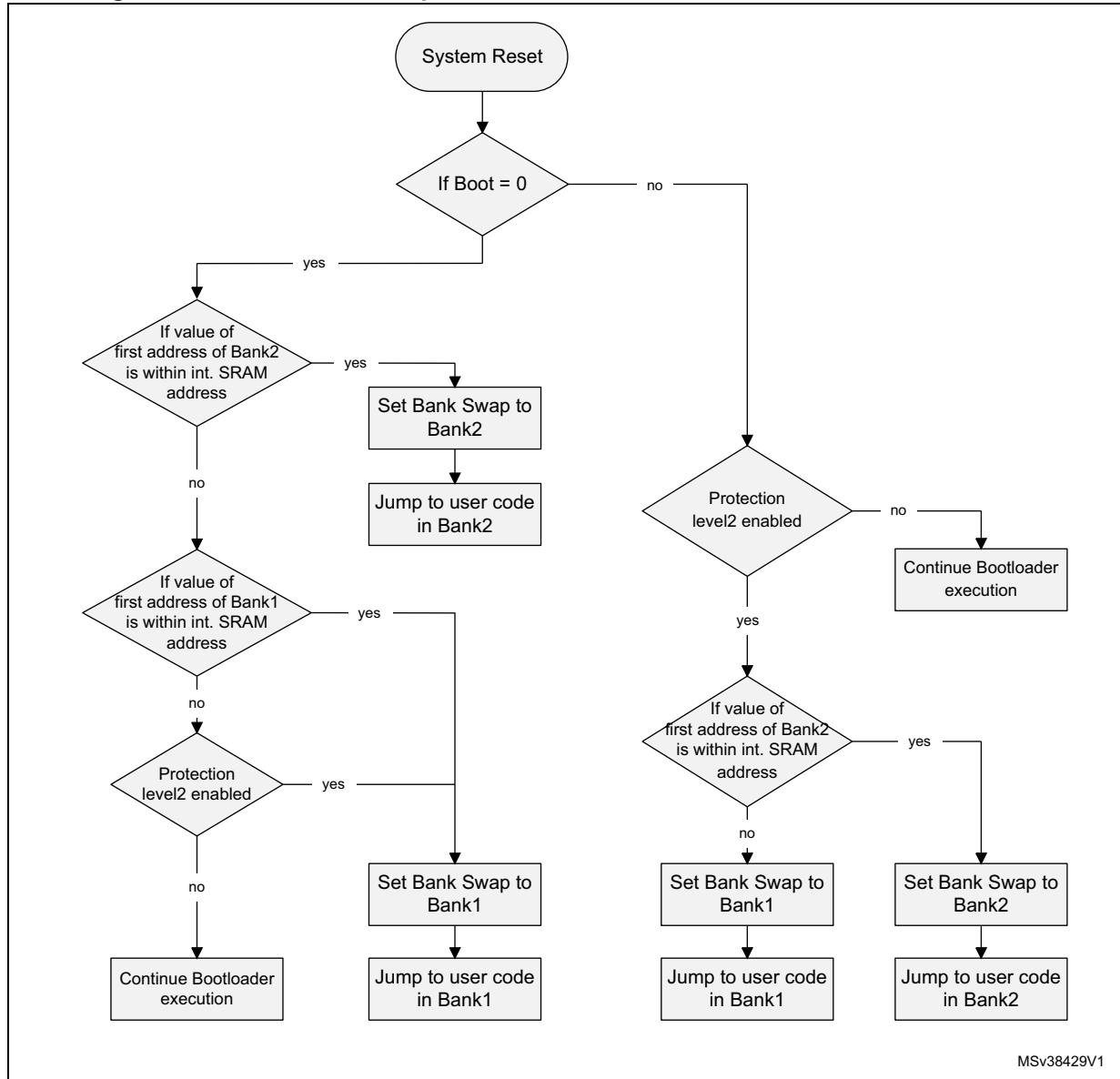
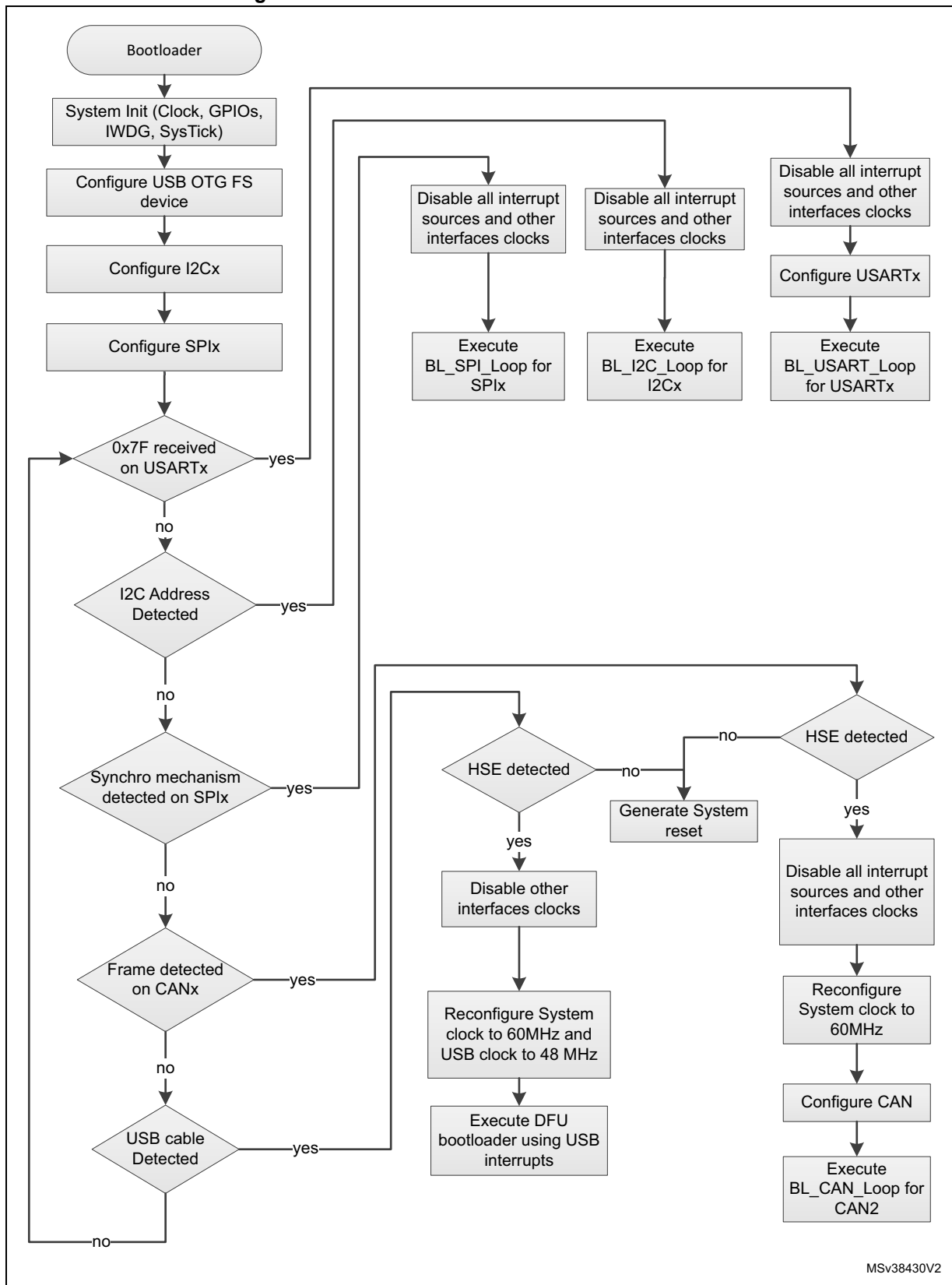

Figure 44.Bootloader V9.x selection for STM32F469xx/479xx



35.3 Bootloader version

[Table 76](#) lists the STM32F469xx/479xx devices V9.x bootloader versions:

Table 76. STM32F469xx/479xx bootloader V9.x versions

Bootloader version number	Description	Known limitations
V9.0	Initial bootloader version	After executing Go command (jump to user code) the bootloader resets AHB1ENR value to 0x0000 0000 and thus CCM RAM, when present, is not active (must be re-enabled by user code at startup).

36 STM32F72xxx/73xxx devices bootloader

36.1 Bootloader configuration

The STM32F72xxx/73xxx bootloader is activated by applying Pattern 8 (described in [Table 2: Bootloader activation patterns](#)). [Table 77](#) shows the hardware resources used by this bootloader.

Table 77. STM32F72xxx/73xxx configuration in system memory boot mode

Bootloader	Feature/Peripheral	State	Comment
Common to all bootloaders	RCC	HSI enabled	The HSI is used at startup as clock source for system clock configured to 60 MHz and for USART and I2C bootloader operation.
		HSE enabled	The HSE is used only when the CAN or the DFU (USB FS Device) interfaces are selected. In this case the system clock configured to 60 MHz with HSE as clock source. The HSE frequency must be multiple of 1 MHz and ranging from 4 MHz to 26 MHz.
		-	The Clock Security System (CSS) interrupt is enabled for the CAN and DFU bootloaders. Any failure (or removal) of the external clock generates system reset.
	RAM	-	16 Kbyte starting from address 0x20000000 are used by the bootloader firmware
	System memory	-	59 Kbyte starting from address 0x1FF00000, contain the bootloader firmware
	IWDG	-	The independent watchdog (IWDG) prescaler is configured to its maximum value. It is periodically refreshed to prevent watchdog reset (in case the hardware IWDG option was previously enabled by the user).
	Power	-	The voltage range is [1.8V, 3.6V] In this range: - Flash wait states: 3. - System clock frequency 60 MHz. - ART Accelerator enabled. - Flash write operation by byte (refer to bootloader memory management section for more information).

Table 77. STM32F72xxx/73xxx configuration in system memory boot mode (continued)

Bootloader	Feature/Peripheral	State	Comment
USART1 bootloader	USART1	Enabled	Once initialized the USART1 configuration is: 8-bit, even parity and 1 Stop bit
	USART1_RX pin	Input	PA10 pin: USART1 in reception mode
	USART1_TX pin	Output	PA9 pin: USART1 in transmission mode
USART3 bootloader (on PB11/PB10)	USART3	Enabled	Once initialized the USART3 configuration is: 8-bit, even parity and 1 Stop bit
	USART3_RX pin	Input	PB11 pin: USART3 in reception mode
	USART3_TX pin	Output	PB10 pin: USART3 in transmission mode
USART3 bootloader (on PC11/PC10)	USART3	Enabled	Once initialized the USART3 configuration is: 8-bit, even parity and 1 Stop bit
	USART3_RX pin	Input	PC11 pin: USART3 in reception mode
	USART3_TX pin	Output	PC10 pin: USART3 in transmission mode
USARTx bootloaders	SysTick timer	Enabled	Used to automatically detect the serial baud rate from the host for USARTx bootloaders.
CAN1 bootloader	CAN1	Enabled	Once initialized the CAN1 configuration is: Baudrate 125 kbps, 11-bit identifier.
	CAN1_RX pin	Input	PD0 pin: CAN1 in reception mode
	CAN1_TX pin	Output	PD1 pin: CAN1 in transmission mode
I2C1 bootloader	I2C1	Enabled	The I2C1 configuration is: I2C speed: up to 400 kHz, 7-bit address, slave mode, analog filter ON. Slave 7-bit address: 0b1001001x (where x = 0 for write and x = 1 for read)
	I2C1_SCL pin	Input/Output	PB6 pin: clock line is used in open-drain mode.
	I2C1_SDA pin	Input/Output	PB9 pin: data line is used in open-drain mode.

Table 77. STM32F72xxx/73xxx configuration in system memory boot mode (continued)

Bootloader	Feature/Peripheral	State	Comment
I2C2 bootloader	I2C2	Enabled	The I2C2 configuration is: I2C speed: up to 400 kHz, 7-bit address, slave mode, analog filter ON. Slave 7-bit address: 0b1001101x (where x = 0 for write and x = 1 for read)
	I2C2_SCL pin	Input/Output	PF1 pin: clock line is used in open-drain mode.
	I2C2_SDA pin	Input/Output	PF0 pin: data line is used in open-drain mode.
I2C3 bootloader	I2C3	Enabled	The I2C3 configuration is: I2C speed: up to 400 kHz, 7-bit address, slave mode, analog filter ON. Slave 7-bit address: 0b1001001x (where x = 0 for write and x = 1 for read)
	I2C3_SCL pin	Input/Output	PA8 pin: clock line is used in open-drain mode.
	I2C3_SDA pin	Input/Output	PC9 pin: data line is used in open-drain mode.
SPI1 bootloader	SPI1	Enabled	The SPI1 configuration is: Slave mode, Full Duplex, 8-bit MSB, Speed up to 8 MHz, Polarity: CPOL Low, CPHA Low, NSS hardware.
	SPI1_MOSI pin	Input	PA7 pin: Slave data Input line, used in push-pull, pull-down mode
	SPI1_MISO pin	Output	PA6 pin: Slave data output line, used in push-pull, pull-down mode
	SPI1_SCK pin	Input	PA5 pin: Slave clock line, used in push-pull, pull-down mode
	SPI1_NSS pin	Input	PA4 pin: slave chip select pin used in push-pull, pull-down mode.
SPI2 bootloader	SPI2	Enabled	The SPI2 configuration is: Slave mode, Full Duplex, 8-bit MSB, Speed up to 8 MHz, Polarity: CPOL Low, CPHA Low, NSS hardware.
	SPI2_MOSI pin	Input	PI3 pin: Slave data Input line, used in push-pull, pull-down mode
	SPI2_MISO pin	Output	PI2 pin: Slave data output line, used in push-pull, pull-down mode
	SPI2_SCK pin	Input	PI1 pin: Slave clock line, used in push-pull, pull-down mode
	SPI2_NSS pin	Input	PI0 pin: slave chip select pin used in push-pull, pull-down mode.

Table 77. STM32F72xxx/73xxx configuration in system memory boot mode (continued)

Bootloader	Feature/Peripheral	State	Comment
SPI4 bootloader	SPI4	Enabled	The SPI4 configuration is: Slave mode, Full Duplex, 8-bit MSB, Speed up to 8 MHz, Polarity: CPOL Low, CPHA Low, NSS hardware.
	SPI4_MOSI pin	Input	PE14 pin: Slave data Input line, used in push-pull, pull-down mode
	SPI4_MISO pin	Output	PE13 pin: Slave data output line, used in push-pull, pull-down mode
	SP4_SCK pin	Input	PE12 pin: Slave clock line, used in push-pull, pull-down mode
	SPI4_NSS pin	Input	PE11 pin: slave chip select pin used in push-pull, pull-down mode.
DFU bootloader	USB	Enabled	USB OTG FS configured in forced device mode
	USB_DM pin	Input/Output	PA11 pin: USB DM line.
	USB_DP pin		PA12 pin: USB DP line No external Pull-Up resistor is required.
CAN1 and DFU bootloaders	TIM11	Enabled	This timer is used to determine the value of the HSE. Once HSE frequency is determined, the system clock is configured to 60 MHz using PLL and HSE.

The system clock is derived from the embedded internal high-speed RC for USARTx and I2Cx bootloaders. This internal clock is also used for CAN and DFU (USB FS Device) but only for the selection phase. An external clock multiple of 1 MHz (between 4 and 26 MHz) is required for CAN and DFU bootloader execution after the selection phase.

Note: Due to HSI deviation and since HSI is used to detect HSE value, the user must use low frequency rather than high frequency HSE crystal values (low frequency values are better detected due to larger error margin). For example, it is better to use 8 MHz instead of 25 MHz.

36.3 Bootloader version

Table 78 lists the STM32F72xxx/73xxx devices bootloader V9.x versions.

Table 78. STM32F72xxx/73xxx bootloader V9.x versions

Bootloader version number	Description	Known limitations
V9.0	Initial bootloader version	At high UART baudrates (115200 bps) connection may fail due to software jitter leading to wrong baudrate calculation. In that case bootloader may respond with a baudrate up to $\pm 5\%$ different from host baudrate. Workaround: use baudrates lower than 57600 bps if host tolerance to baudrate error is lower than $\pm 5\%$

37 STM32F74xxx/75xxx devices bootloader

Two bootloader versions are available on STM32F74xxx/75xxx:

- V7.x supporting USART1, USART3, CAN2, I2C1, I2C2, I2C3 and DFU (USB FS Device). This version is embedded in STM32F74xxx/75xxx rev. A devices.
- V9.x supporting USART1, USART3, CAN2, I2C1, I2C2, I2C3, SPI1, SPI2, SPI4 and DFU (USB FS Device). This version is embedded in STM32F74xxx/75xxx rev. Z and rev. 1 devices.

Note: When readout protection Level2 is activated, STM32F74xxx/75xxx devices can boot also on system memory and all commands are not accessible except *Get*, *GetID*, and *GetVersion*.

37.1 Bootloader V7.x

37.1.1 Bootloader configuration

The STM32F74xxx/75xxx bootloader is activated by applying Pattern 8 (described in [Table 2: Bootloader activation patterns](#)). [Table 79](#) shows the hardware resources used by this bootloader.

Table 79. STM32F74xxx/75xxx configuration in system memory boot mode

Bootloader	Feature/Peripheral	State	Comment
Common to all bootloaders	RCC	HSI enabled	The HSI is used at startup as clock source for system clock configured to 60 MHz and for USART and I2C bootloader operation.
		HSE enabled	The HSE is used only when the CAN or the DFU (USB FS Device) interfaces are selected. In this case the system clock configured to 60 MHz with HSE as clock source. The HSE frequency must be multiple of 1 MHz and ranging from 4 MHz to 26 MHz.
		-	The Clock Security System (CSS) interrupt is enabled for the CAN and DFU bootloaders. Any failure (or removal) of the external clock generates system reset.
	RAM	-	16 Kbyte starting from address 0x20000000 are used by the bootloader firmware
	System memory	-	60 Kbyte starting from address 0x1FF00000, contain the bootloader firmware
	IWDG	-	The independent watchdog (IWDG) prescaler is configured to its maximum value. It is periodically refreshed to prevent watchdog reset (in case the hardware IWDG option was previously enabled by the user).
Power	-	The voltage range is [1.8V, 3.6V]. In this range: - Flash wait states: 3. - System clock frequency 60 MHz. - ART Accelerator enabled. - Flash write operation by byte (refer to bootloader memory management section for more information).	
USART1 bootloader	USART1	Enabled	Once initialized the USART1 configuration is: 8-bit, even parity and 1 Stop bit
	USART1_RX pin	Input	PA10 pin: USART1 in reception mode
	USART1_TX pin	Output	PA9 pin: USART1 in transmission mode
USART3 bootloader (on PB10/PB11)	USART3	Enabled	Once initialized the USART3 configuration is: 8-bit, even parity and 1 Stop bit
	USART3_RX pin	Input	PB11 pin: USART3 in reception mode
	USART3_TX pin	Output	PB10 pin: USART3 in transmission mode

Table 79. STM32F74xxx/75xxx configuration in system memory boot mode (continued)

Bootloader	Feature/Peripheral	State	Comment
USART3 bootloader (on PC10/PC11)	USART3	Enabled	Once initialized the USART3 configuration is: 8-bit, even parity and 1 Stop bit
	USART3_RX pin	Input	PC11 pin: USART3 in reception mode
	USART3_TX pin	Output	PC10 pin: USART3 in transmission mode
USARTx bootloaders	SysTick timer	Enabled	Used to automatically detect the serial baud rate from the host for USARTx bootloaders.
CAN2 bootloader	CAN2	Enabled	Once initialized the CAN2 configuration is: Baudrate 125 kbps, 11-bit identifier. Note: CAN1 is clocked during CAN2 bootloader execution because CAN1 manages the communication between CAN2 and SRAM.
	CAN2_RX pin	Input	PB5 pin: CAN2 in reception mode
	CAN2_TX pin	Output	PB13 pin: CAN2 in transmission mode
I2C1 bootloader	I2C1	Enabled	The I2C1 configuration is: I2C speed: up to 400 kHz, 7-bit address, slave mode, analog filter ON. Slave 7-bit address: 0b1000101x (where x = 0 for write and x = 1 for read)
	I2C1_SCL pin	Input/Output	PB6 pin: clock line is used in open-drain mode.
	I2C1_SDA pin	Input/Output	PB9 pin: data line is used in open-drain mode.
I2C2 bootloader	I2C2	Enabled	The I2C2 configuration is: I2C speed: up to 400 kHz, 7-bit address, slave mode, analog filter ON. Slave 7-bit address: 0b1000101x (where x = 0 for write and x = 1 for read)
	I2C2_SCL pin	Input/Output	PF1 pin: clock line is used in open-drain mode.
	I2C2_SDA pin	Input/Output	PF0 pin: data line is used in open-drain mode.
I2C3 bootloader	I2C3	Enabled	The I2C3 configuration is: I2C speed: up to 400 kHz, 7-bit address, slave mode, analog filter ON. Slave 7-bit address: 0b1000101x (where x = 0 for write and x = 1 for read)
	I2C3_SCL pin	Input/Output	PA8 pin: clock line is used in open-drain mode.
	I2C3_SDA pin	Input/Output	PC9 pin: data line is used in open-drain mode.
DFU bootloader	USB	Enabled	USB OTG FS configured in forced device mode.
	USB_DM pin	Input/Output	PA11 pin: USB DM line.
	USB_DP pin		PA12 pin: USB DP line No external Pull-Up resistor is required.
CAN2 and DFU bootloaders	TIM11	Enabled	This timer is used to determine the value of the HSE. Once HSE frequency is determined, the system clock is configured to 60 MHz using PLL and HSE.

The system clock is derived from the embedded internal high-speed RC for USARTx and I2Cx bootloaders. This internal clock is also used for CAN and DFU (USB FS Device) but

only for the selection phase. An external clock multiple of 1 MHz (between 4 and 26 MHz) is required for CAN and DFU bootloader execution after the selection phase.

Note: Due to HSI deviation and since HSI is used to detect HSE value, the user must use low frequency rather than high frequency HSE crystal values (low frequency values are better detected due to larger error margin). For example, it is better to use 8 MHz instead of 25 MHz.

37.1.2 Bootloader selection

The figure below shows the bootloader selection mechanism.

Figure 46.Bootloader V7.x selection for STM32F74xxx/75xxx

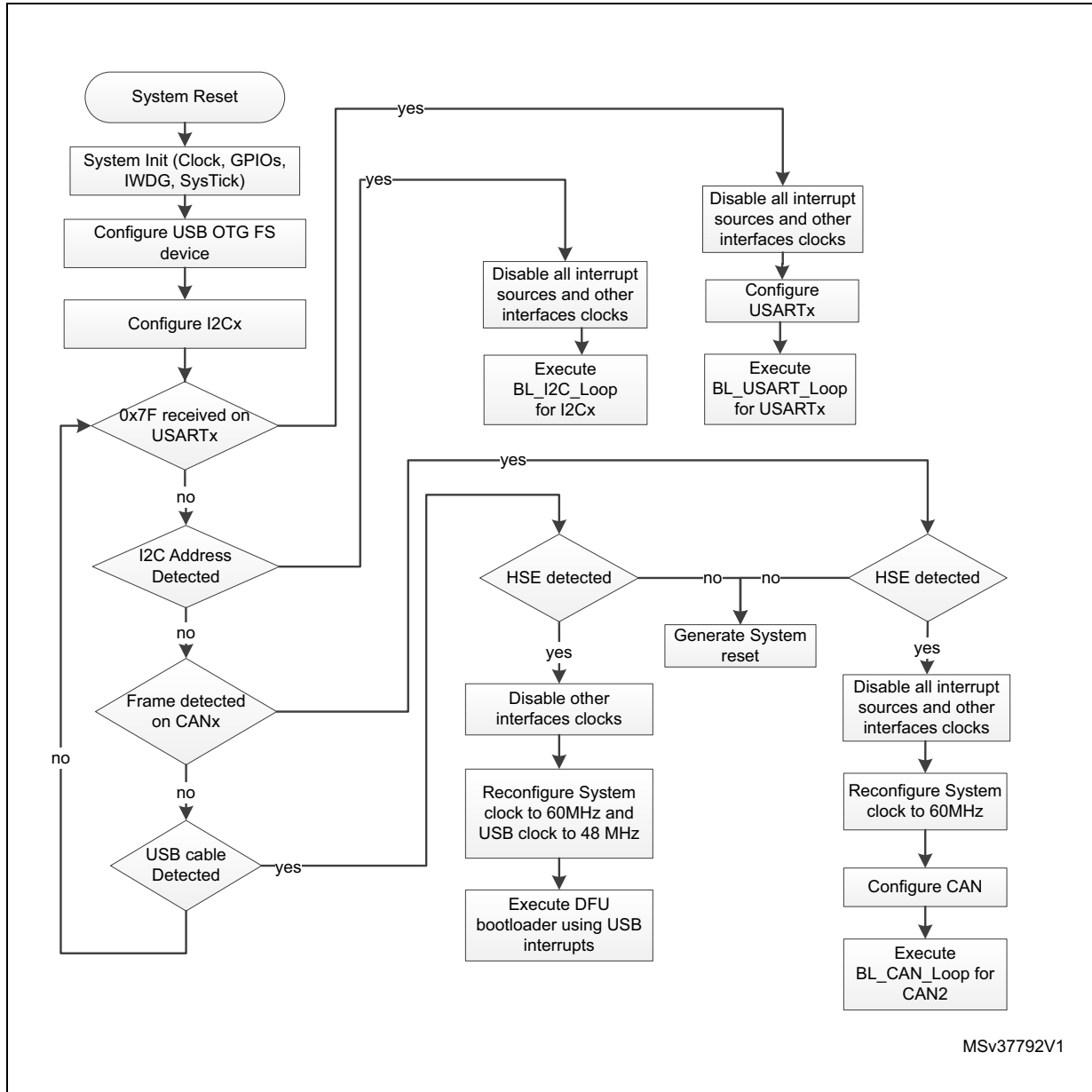

37.1.3 Bootloader version

The following table lists the STM32F74xxx/75xxx devices bootloader V7.x versions:

Table 80. STM32F74xxx/75xxx bootloader V7.x versions

Bootloader version number	Description	Known limitations
V7.0	Initial bootloader version	At high UART baudrates (115200 bps) connection may fail due to software jitter leading to wrong baudrate calculation. In that case bootloader may respond with a baudrate up to $\pm 5\%$ different from host baudrate. Workaround: use baudrates lower than 57600 bps if host tolerance to baudrate error is lower than $\pm 5\%$

37.2 Bootloader V9.x

37.2.1 Bootloader configuration

The STM32F74xxx/75xxx bootloader is activated by applying Pattern 8 (described in [Table 2: Bootloader activation patterns](#)). The following table shows the hardware resources used by this bootloader.

Table 81. STM32F74xxx/75xxx configuration in system memory boot mode

Bootloader	Feature/Peripheral	State	Comment
Common to all bootloaders	RCC	HSI enabled	The HSI is used at startup as clock source for system clock configured to 60 MHz and for USART, I2C and SPI bootloader operation.
		HSE enabled	The HSE is used only when the CAN or the DFU (USB FS Device) interfaces are selected. In this case the system clock configured to 60 MHz with HSE as clock source. The HSE frequency must be multiple of 1 MHz and ranging from 4 MHz to 26 MHz.
		-	The Clock Security System (CSS) interrupt is enabled for the CAN and DFU bootloaders. Any failure (or removal) of the external clock generates system reset.
	RAM	-	16 Kbyte starting from address 0x20000000 are used by the bootloader firmware
	System memory	-	60 Kbyte starting from address 0x1FF00000, contain the bootloader firmware
	IWDG	-	The independent watchdog (IWDG) prescaler is configured to its maximum value. It is periodically refreshed to prevent watchdog reset (in case the hardware IWDG option was previously enabled by the user).
	Power	-	The voltage range is [1.8V, 3.6V] In this range: - Flash wait states: 3. - System clock frequency 60 MHz. - ART Accelerator enabled. - Flash write operation by byte (refer to bootloader memory management section for more information).

Table 81. STM32F74xxx/75xxx configuration in system memory boot mode (continued)

Bootloader	Feature/Peripheral	State	Comment
USART1 bootloader	USART1	Enabled	Once initialized the USART1 configuration is: 8-bit, even parity and 1 Stop bit
	USART1_RX pin	Input	PA10 pin: USART1 in reception mode
	USART1_TX pin	Output	PA9 pin: USART1 in transmission mode
USART3 bootloader (on PB10/PB11)	USART3	Enabled	Once initialized the USART3 configuration is: 8-bit, even parity and 1 Stop bit
	USART3_RX pin	Input	PB11 pin: USART3 in reception mode
	USART3_TX pin	Output	PB10 pin: USART3 in transmission mode
USART3 bootloader (on PC10/PC11)	USART3	Enabled	Once initialized the USART3 configuration is: 8-bit, even parity and 1 Stop bit
	USART3_RX pin	Input	PC11 pin: USART3 in reception mode
	USART3_TX pin	Output	PC10 pin: USART3 in transmission mode
USARTx bootloaders	SysTick timer	Enabled	Used to automatically detect the serial baud rate from the host for USARTx bootloaders.
CAN2 bootloader	CAN2	Enabled	Once initialized the CAN2 configuration is: Baudrate 125 kbps, 11-bit identifier. Note: CAN1 is clocked during CAN2 bootloader execution because CAN1 manages the communication between CAN2 and SRAM.
	CAN2_RX pin	Input	PB5 pin: CAN2 in reception mode
	CAN2_TX pin	Output	PB13 pin: CAN2 in transmission mode
I2C1 bootloader	I2C1	Enabled	The I2C1 configuration is: I2C speed: up to 400 kHz, 7-bit address, slave mode, analog filter ON. Slave 7-bit address: 0b1000101x (where x = 0 for write and x = 1 for read)
	I2C1_SCL pin	Input/output	PB6 pin: clock line is used in open-drain mode.
	I2C1_SDA pin	Input/output	PB9 pin: data line is used in open-drain mode.
I2C2 bootloader	I2C2	Enabled	The I2C2 configuration is: I2C speed: up to 400 kHz, 7-bit address, slave mode, analog filter ON. Slave 7-bit address: 0b1000101x (where x = 0 for write and x = 1 for read)
	I2C2_SCL pin	Input/output	PF1 pin: clock line is used in open-drain mode.
	I2C2_SDA pin	Input/output	PF0 pin: data line is used in open-drain mode.

Table 81. STM32F74xxx/75xxx configuration in system memory boot mode (continued)

Bootloader	Feature/Peripheral	State	Comment
I2C3 bootloader	I2C3	Enabled	The I2C3 configuration is: I2C speed: up to 400 kHz, 7-bit address, slave mode, analog filter ON. Slave 7-bit address: 0b1000101x (where x = 0 for write and x = 1 for read)
	I2C3_SCL pin	Input/output	PA8 pin: clock line is used in open-drain mode.
	I2C3_SDA pin	Input/output	PC9 pin: data line is used in open-drain mode.
SPI1 bootloader	SPI1	Enabled	The SPI1 configuration is: Slave mode, Full Duplex, 8-bit MSB, Speed up to 8 MHz, Polarity: CPOL Low, CPHA Low, NSS hardware.
	SPI1_MOSI pin	Input	PA7 pin: Slave data Input line, used in push-pull, pull-down mode
	SPI1_MISO pin	Output	PA6 pin: Slave data output line, used in push-pull, pull-down mode
	SPI1_SCK pin	Input	PA5 pin: Slave clock line, used in push-pull, pull-down mode
	SPI1_NSS pin	Input	PA4 pin: slave chip select pin used in push-pull, pull-down mode.
SPI2 bootloader	SPI2	Enabled	The SPI2 configuration is: Slave mode, Full Duplex, 8-bit MSB, Speed up to 8 MHz, Polarity: CPOL Low, CPHA Low, NSS hardware.
	SPI2_MOSI pin	Input	PI3 pin: Slave data Input line, used in push-pull, pull-down mode
	SPI2_MISO pin	Output	PI2 pin: Slave data output line, used in push-pull, pull-down mode
	SPI2_SCK pin	Input	PI1 pin: Slave clock line, used in push-pull, pull-down mode
	SPI2_NSS pin	Input	PI0 pin: slave chip select pin used in push-pull, pull-down mode.

Table 81. STM32F74xxx/75xxx configuration in system memory boot mode (continued)

Bootloader	Feature/Peripheral	State	Comment
SPI4 bootloader	SPI4	Enabled	The SPI4 configuration is: Slave mode, Full Duplex, 8-bit MSB, Speed up to 8 MHz, Polarity: CPOL Low, CPHA Low, NSS hardware.
	SPI4_MOSI pin	Input	PE14 pin: Slave data Input line, used in push-pull, pull-down mode
	SPI4_MISO pin	Output	PE13 pin: Slave data output line, used in push-pull, pull-down mode
	SP4_SCK pin	Input	PE12 pin: Slave clock line, used in push-pull, pull-down mode
	SPI4_NSS pin	Input	PE11 pin: slave chip select pin used in push-pull, pull-down mode.
DFU bootloader	USB	Enabled	USB OTG FS configured in forced device mode.
	USB_DM pin	Input/Output	PA11 pin: USB DM line.
	USB_DP pin		PA12 pin: USB DP line No external pull-Up resistor is required.
CAN2 and DFU bootloaders	TIM11	Enabled	This timer is used to determine the value of the HSE. Once HSE frequency is determined, the system clock is configured to 60 MHz using PLL and HSE.

The system clock is derived from the embedded internal high-speed RC for USARTx, I2Cx and SPIx bootloaders. This internal clock is also used for CAN and DFU (USB FS Device) but only for the selection phase. An external clock multiple of 1 MHz (between 4 and 26 MHz) is required for CAN and DFU bootloader execution after the selection phase.

Note: Due to HSI deviation and since HSI is used to detect HSE value, the user must use low frequency rather than high frequency HSE crystal values (low frequency values are better detected due to larger error margin). For example, it is better to use 8 MHz instead of 25 MHz.

37.2.2 Bootloader selection

Figure 47 shows the bootloader selection mechanism.

Figure 47.Bootloader V9.x selection for STM32F74xxx/75xxx

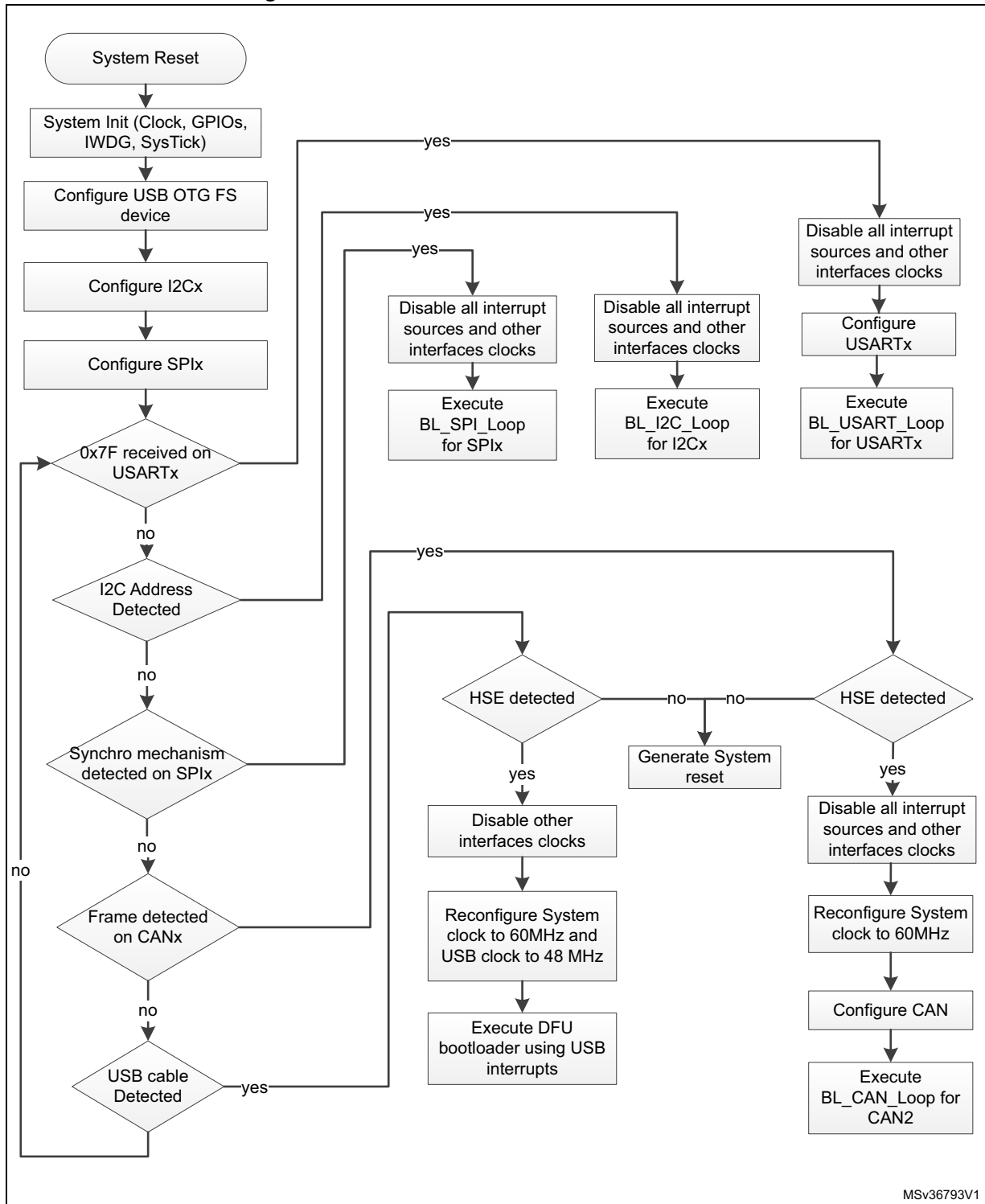

MSv36793V1

37.2.3 Bootloader version

The following table lists the STM32F74xxx/75xxx bootloader V9.x versions:

Table 82. STM32F74xxx/75xxx bootloader V9.x versions

Bootloader version number	Description	Known limitations
V9.0	Initial bootloader version	At high UART baudrates (115200 bps) connection may fail due to software jitter leading to wrong baudrate calculation. In that case bootloader may respond with a baudrate up to $\pm 5\%$ different from host baudrate. Workaround: use baudrates lower than 57600 bps if host tolerance to baudrate error is lower than $\pm 5\%$

38 STM32F76xxx/77xxx devices bootloader

38.1 Bootloader configuration

The STM32F76xxx/77xxx bootloader is activated by applying Pattern 9 (described in [Table 2: Bootloader activation patterns](#)). The following table shows the hardware resources used by this bootloader.

Table 83. STM32F76xxx/77xxx configuration in system memory boot mode

Bootloader	Feature/Peripheral	State	Comment
Common to all bootloaders	RCC	HSI enabled	The HSI is used at startup as clock source for system clock configured to 60 MHz and for USART and I2C bootloader operation.
		HSE enabled	The HSE is used only when the CAN or the DFU (USB FS Device) interfaces are selected. In this case the system clock configured to 60 MHz with HSE as clock source. The HSE frequency must be multiple of 1 MHz and ranging from 4 MHz to 26 MHz.
		-	The Clock Security System (CSS) interrupt is enabled for the CAN and DFU bootloaders. Any failure (or removal) of the external clock generates system reset.
	RAM	-	16 Kbyte starting from address 0x20000000 are used by the bootloader firmware
	System memory	-	59 Kbyte starting from address 0x1FF00000, contain the bootloader firmware
	IWDG	-	The independent watchdog (IWDG) prescaler is configured to its maximum value. It is periodically refreshed to prevent watchdog reset (in case the hardware IWDG option was previously enabled by the user).
	Power	-	The voltage range is [1.8V, 3.6V] In this range: - Flash wait states: 3. - System clock frequency 60 MHz. - ART Accelerator enabled. - Flash write operation by byte (refer to bootloader memory management section for more information).

Table 83. STM32F76xxx/77xxx configuration in system memory boot mode (continued)

Bootloader	Feature/Peripheral	State	Comment
USART1 bootloader	USART1	Enabled	Once initialized the USART1 configuration is: 8-bit, even parity and 1 Stop bit
	USART1_RX pin	Input	PA10 pin: USART1 in reception mode
	USART1_TX pin	Output	PA9 pin: USART1 in transmission mode
USART3 bootloader (on PB11/PB10)	USART3	Enabled	Once initialized the USART3 configuration is: 8-bit, even parity and 1 Stop bit
	USART3_RX pin	Input	PB11 pin: USART3 in reception mode
	USART3_TX pin	Output	PB10 pin: USART3 in transmission mode
USART3 bootloader (on PC11/PC10)	USART3	Enabled	Once initialized the USART3 configuration is: 8-bit, even parity and 1 Stop bit
	USART3_RX pin	Input	PC11 pin: USART3 in reception mode
	USART3_TX pin	Output	PC10 pin: USART3 in transmission mode
USARTx bootloaders	SysTick timer	Enabled	Used to automatically detect the serial baud rate from the host for USARTx bootloaders.
CAN2 bootloader	CAN2	Enabled	Once initialized the CAN2 configuration is: Baudrate 125 kbps, 11-bit identifier. Note: CAN1 is clocked during CAN2 bootloader execution because CAN1 manages the communication between CAN2 and SRAM.
	CAN2_RX pin	Input	PB5 pin: CAN2 in reception mode
	CAN2_TX pin	Output	PB13 pin: CAN2 in transmission mode
I2C1 bootloader	I2C1	Enabled	The I2C1 configuration is: I2C speed: up to 400 kHz, 7-bit address, slave mode, analog filter ON. Slave 7-bit address: 0b1001001x (where x = 0 for write and x = 1 for read)
	I2C1_SCL pin	Input/Output	PB6 pin: clock line is used in open-drain mode.
	I2C1_SDA pin	Input/Output	PB9 pin: data line is used in open-drain mode.
I2C2 bootloader	I2C2	Enabled	The I2C2 configuration is: I2C speed: up to 400 kHz, 7-bit address, slave mode, analog filter ON. Slave 7-bit address: 0b1001001x (where x = 0 for write and x = 1 for read)
	I2C2_SCL pin	Input/Output	PF1 pin: clock line is used in open-drain mode.
	I2C2_SDA pin	Input/Output	PF0 pin: data line is used in open-drain mode.

Table 83. STM32F76xxx/77xxx configuration in system memory boot mode (continued)

Bootloader	Feature/Peripheral	State	Comment
I2C3 bootloader	I2C3	Enabled	The I2C3 configuration is: I2C speed: up to 400 kHz, 7-bit address, slave mode, analog filter ON. Slave 7-bit address: 0b1001001x (where x = 0 for write and x = 1 for read)
	I2C3_SCL pin	Input/Output	PA8 pin: clock line is used in open-drain mode.
	I2C3_SDA pin	Input/Output	PC9 pin: data line is used in open-drain mode.
SPI1 bootloader	SPI1	Enabled	The SPI1 configuration is: Slave mode, Full Duplex, 8-bit MSB, Speed up to 8 MHz, Polarity: CPOL Low, CPHA Low, NSS hardware.
	SPI1_MOSI pin	Input	PA7 pin: Slave data Input line, used in push-pull, pull-down mode
	SPI1_MISO pin	Output	PA6 pin: Slave data output line, used in push-pull, pull-down mode
	SPI1_SCK pin	Input	PA5 pin: Slave clock line, used in push-pull, pull-down mode
	SPI1_NSS pin	Input	PA4 pin: slave chip select pin used in push-pull, pull-down mode.
SPI2 bootloader	SPI2	Enabled	The SPI2 configuration is: Slave mode, Full Duplex, 8-bit MSB, Speed up to 8 MHz, Polarity: CPOL Low, CPHA Low, NSS hardware.
	SPI2_MOSI pin	Input	PI3 pin: Slave data Input line, used in push-pull, pull-down mode
	SPI2_MISO pin	Output	PI2 pin: Slave data output line, used in push-pull, pull-down mode
	SPI2_SCK pin	Input	PI1 pin: Slave clock line, used in push-pull, pull-down mode
	SPI2_NSS pin	Input	PI0 pin: slave chip select pin used in push-pull, pull-down mode.

Table 83. STM32F76xxx/77xxx configuration in system memory boot mode (continued)

Bootloader	Feature/Peripheral	State	Comment
SPI4 bootloader	SPI4	Enabled	The SPI4 configuration is: Slave mode, Full Duplex, 8-bit MSB, Speed up to 8 MHz, Polarity: CPOL Low, CPHA Low, NSS hardware.
	SPI4_MOSI pin	Input	PE14 pin: Slave data Input line, used in push-pull, pull-down mode
	SPI4_MISO pin	Output	PE13 pin: Slave data output line, used in push-pull, pull-down mode
	SP4_SCK pin	Input	PE12 pin: Slave clock line, used in push-pull, pull-down mode
	SPI4_NSS pin	Input	PE11 pin: slave chip select pin used in push-pull, pull-down mode.
DFU bootloader	USB	Enabled	USB OTG FS configured in forced device mode
	USB_DM pin	Input/Output	PA11 pin: USB DM line.
	USB_DP pin		PA12 pin: USB DP line No external pull-Up resistor is required.
CAN2 and DFU bootloaders	TIM11	Enabled	This timer is used to determine the value of the HSE. Once HSE frequency is determined, the system clock is configured to 60 MHz using PLL and HSE.

The system clock is derived from the embedded internal high-speed RC for USARTx and I2Cx bootloaders. This internal clock is also used for CAN and DFU (USB FS Device) but only for the selection phase. An external clock multiple of 1 MHz (between 4 and 26 MHz) is required for CAN and DFU bootloader execution after the selection phase.

Note: Due to HSI deviation and since HSI is used to detect HSE value, the user must use low frequency rather than high frequency HSE crystal values (low frequency values are better detected due to larger error margin). For example, it is better to use 8 MHz instead of 25 MHz.

38.2 Bootloader selection

Figure 48 and Figure 49 show the bootloader selection mechanism.

Figure 48. Dual bank boot implementation for STM32F76xxx/77xxx Bootloader V9.x

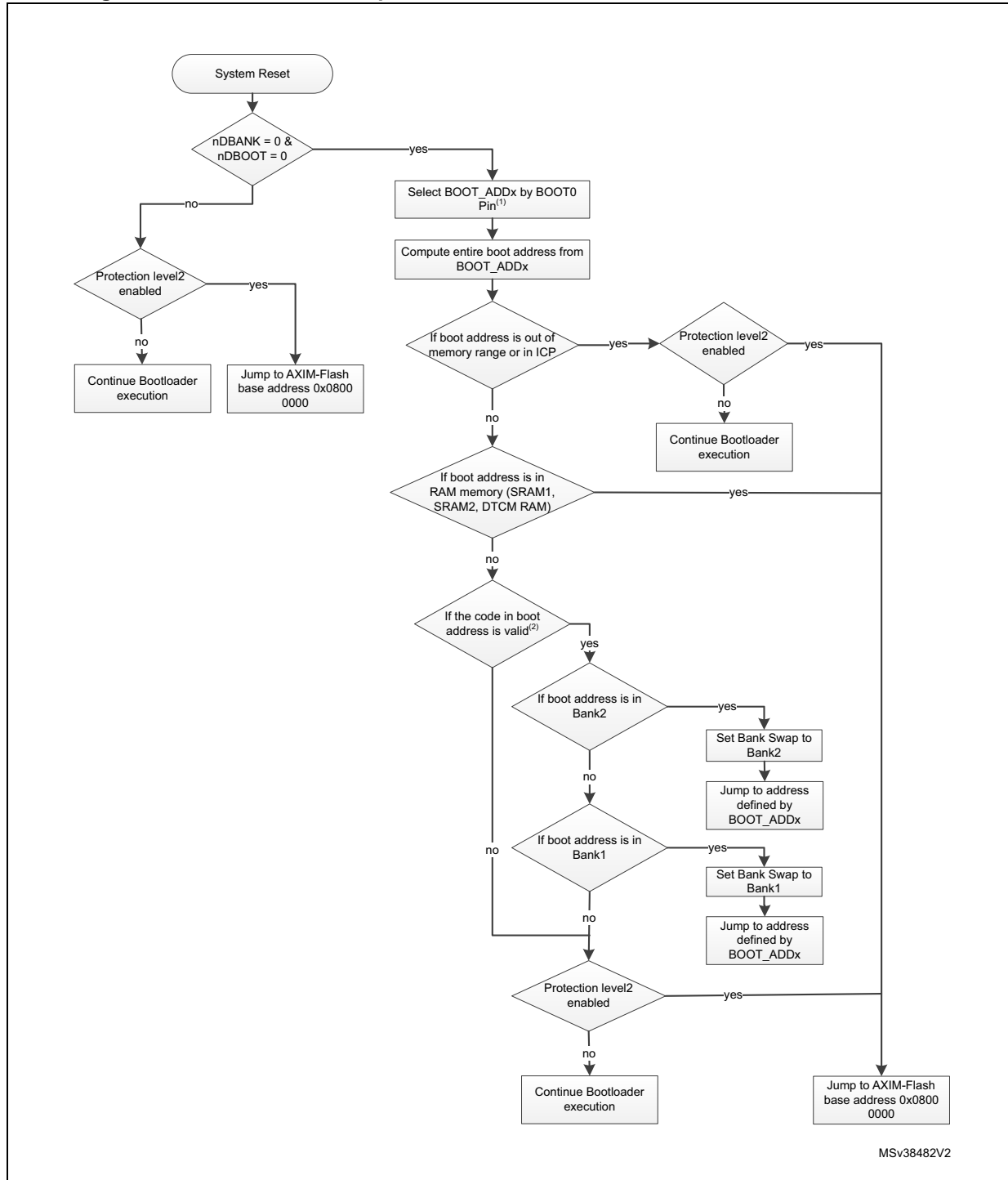

1. Only BOOT_ADD0 value is considered whatever the BOOT0 pin state, as described in Known limitation under Table 84.
2. ITCM RAM is not considered valid as stack pointer address for the dual bank boot mechanism.

Figure 49. Bootloader V9.x selection for STM32F76xxx/77xxx

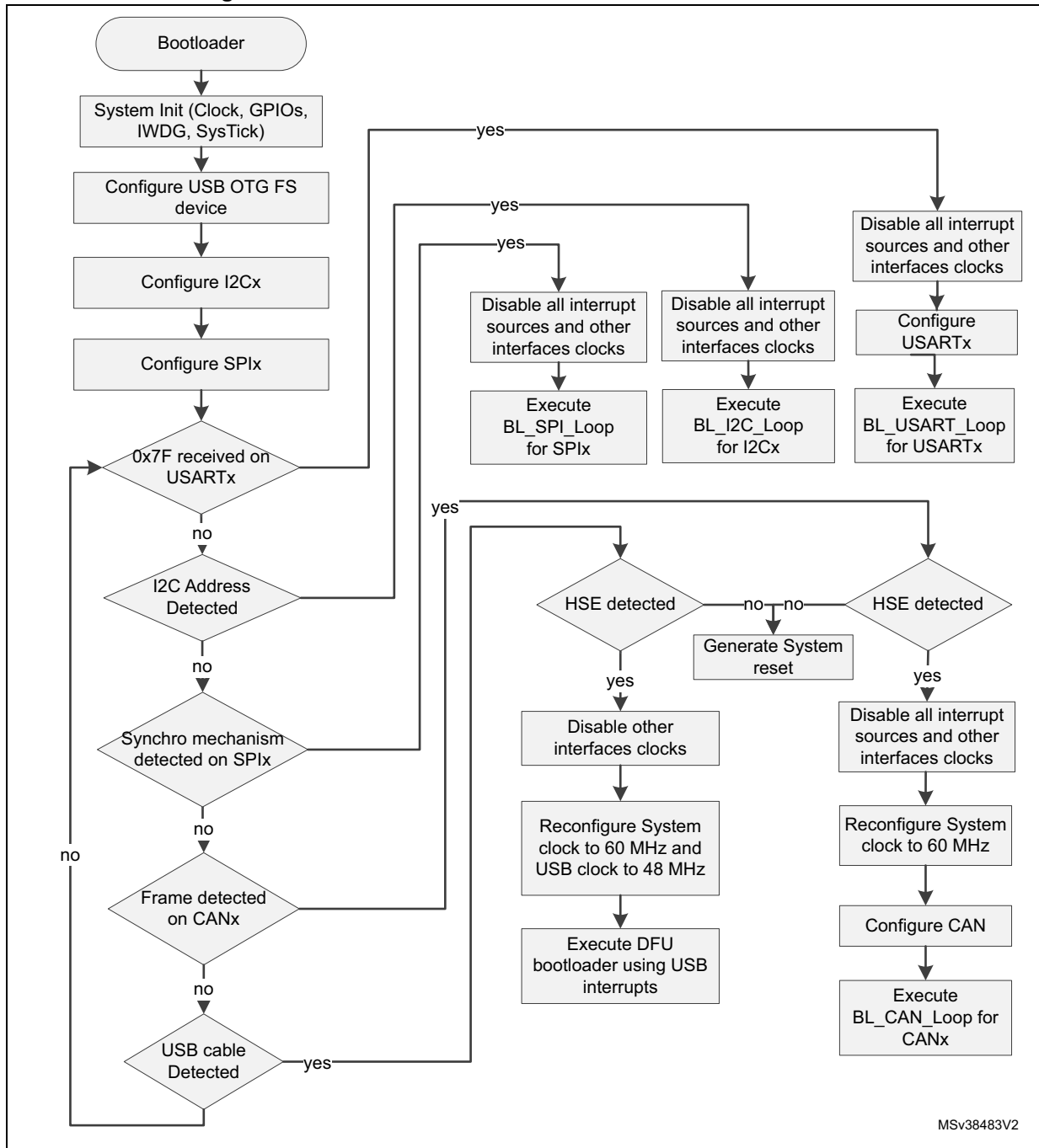

MSv38483V2

38.3 Bootloader version

The following table lists the STM32F76xxx/77xxx devices bootloader V9.x versions.

Table 84. STM32F76xxx/77xxx bootloader V9.x versions

Bootloader version number	Description	Known limitations
V9.3	Initial bootloader version	<p>When the Flash memory is configured to the dual bank boot mode (nDBANK=nDBOOT=0), whatever the BOOT0 Pin state only BOOT_ADD0 value is considered (when BOOT0 Pin=1, BOOT_ADD0 value is considered not the BOOT_ADD1).</p> <p>Workaround: in order to manage dual bank boot with BOOT_ADD0 only, refer to the AN4826: "STM32F7 Series Flash memory dual bank mode"</p> <p>At high UART baudrates (115200 bps) connection may fail due to software jitter leading to wrong baudrate calculation.</p> <p>In that case bootloader may respond with a baudrate up to ± 5% different from host baudrate.</p> <p>Workaround: use baudrates lower than 57600 bps if host tolerance to baudrate error is lower than ± 5%.</p> <p>Bank2 sector erase issue when using USB interface. Erasing a sector from bank2 with index (i) will lead to erase sector (i+4)</p>

39 STM32G03xxx/ STM32G04xxx devices bootloader

39.1 Bootloader configuration

The STM32G03xxx/G04xxx bootloader is activated by applying Pattern 11 (described in [Table 2: Bootloader activation patterns](#)). The following table shows the hardware resources used by this bootloader.

Table 85. STM32G03xxx/G04xxx configuration in system memory boot mode

Bootloader	Feature/Peripheral	State	Comment
Common to all bootloaders	RCC	HSI enabled	The system clock frequency is 24 MHz (using PLL clocked by HSI).
	RAM	-	4 Kbytes starting from address 0x20000000 are used by the bootloader firmware
	System memory	-	8 Kbytes starting from address 0x1FFF0000
	IWDG	-	The independent watchdog (IWDG) prescaler is configured to its maximum value. It is periodically refreshed to prevent watchdog reset (in case the hardware IWDG option was previously enabled by the user).
Securable memory area	-	-	The Address to jump to for the securable memory area: @0x1FFF1D00
USART1 bootloader	USART1	Enabled	Once initialized the USART1 configuration is: 8-bit, even parity and 1 Stop bit
	USART1_RX pin	Input	PA10 pin: USART1 in reception mode
	USART1_TX pin	Output	PA9 pin: USART1 in transmission mode
USART2 bootloader	USART2	Enabled	Once initialized the USART2 configuration is: 8-bit, even parity and 1 Stop bit
	USART2_RX pin	Input	PA3 pin: USART2 in reception mode
	USART2_TX pin	Output	PA2 pin: USART2 in transmission mode
USARTx bootloader	SysTick timer	Enabled	Used to automatically detect the serial baud rate from the host for USARTx bootloaders.
I2C1 bootloader	I2C1	Enabled	The I2C1 configuration is: I2C speed: up to 1 MHz, 7-bit address, slave mode, analog filter ON. Slave 7-bit address: 0b1010110x (where x = 0 for write and x = 1 for read)
	I2C1_SCL pin	Input/Output	PB6 pin: clock line is used in open-drain mode.
	I2C1_SDA pin	Input/Output	PB7 pin: data line is used in open-drain mode.

Table 85. STM32G03xxx/G04xxx configuration in system memory boot mode (continued)

Bootloader	Feature/Peripheral	State	Comment
I2C2 bootloader	I2C2	Enabled	The I2C2 configuration is: I2C speed: up to 1 MHz, 7-bit address, slave mode, analog filter ON. Slave 7-bit address: 0b1010110x (where x = 0 for write and x = 1 for read)
	I2C2_SCL pin	Input/Output	PB10 pin: clock line is used in open-drain mode.
	I2C2_SDA pin	Input/Output	PB11 pin: data line is used in open-drain mode.

Note: On SO8, WLCSP18, TSSOP20 and UFQFN28 packages USART1 PA9/PA10 IOs are remapped on PA11/PA12.

39.2 Bootloader selection

Figure 50 shows the bootloader selection mechanism.

Figure 50. Bootloader V5.x selection for STM32G03xxx/G04xxx

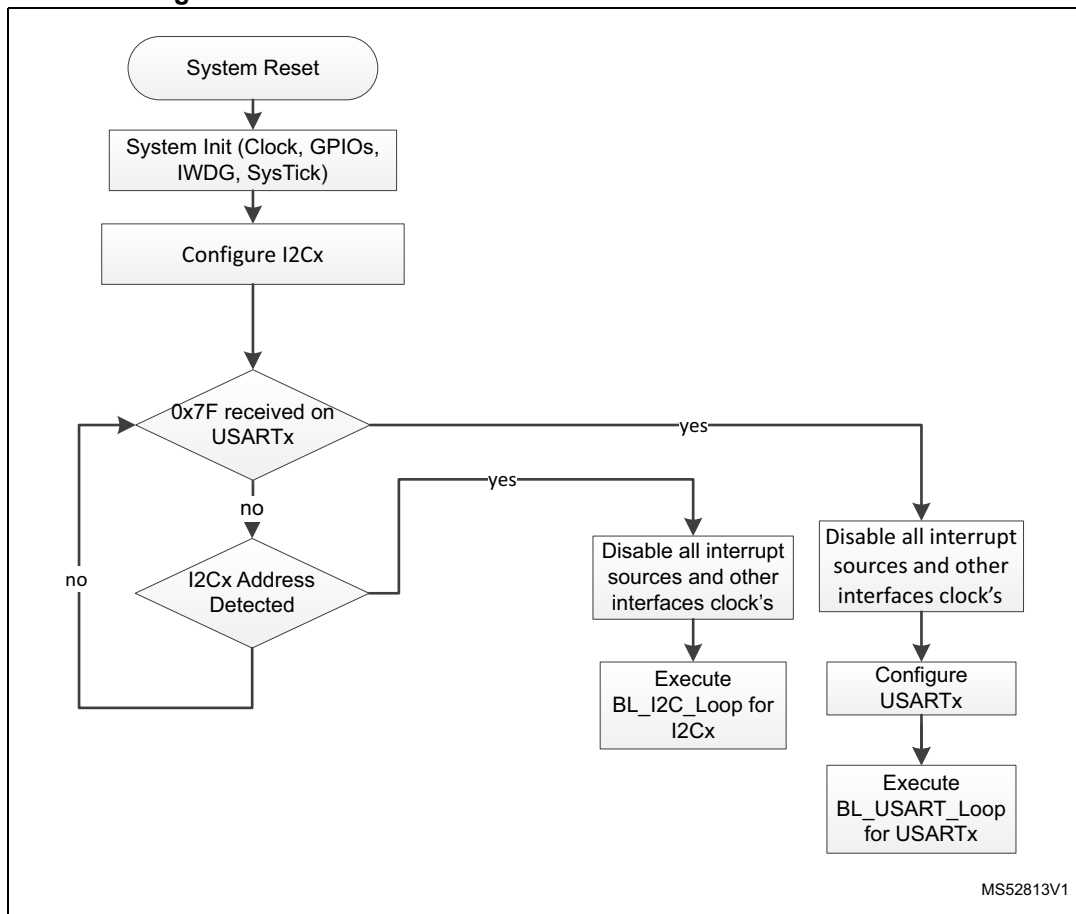

39.3 Bootloader version

[Table 86](#) lists the STM32G03xxx/G4xxx devices bootloader versions.

Table 86. STM32G03xx/04xxx bootloader versions

Bootloader version number	Description	Known limitations
V5.1	Initial bootloader version	<ul style="list-style-type: none"> – Supports only 48- and 32-pin packages – Issue is seen for both packages, if PA3 stays to low level, system is stuck in the USART2 detection sequence and no other interface is detected.
V5.2	Add support to small packages 8/20 and 28 pins	Issue is seen for all packages (except SO8, no PA3 pin), if PA3 stays to low level, system is stuck in the USART2 detection sequence and no other interface is detected.
V5.3	Fix V5.2 limitations	None

40 STM32G07xxx/08xxx device bootloader

40.1 Bootloader configuration

The STM32G07xxx/G08xxx bootloader is activated by applying Pattern 11 (described in [Table 2: Bootloader activation patterns](#)). The following table shows the hardware resources used by this bootloader.

Table 87. STM32G07xxx/8xxx configuration in system memory boot mode

Bootloader	Feature/Peripheral	State	Comment
Common to all bootloaders	RCC	HSI enabled	The system clock frequency is 24 MHz (using PLL clocked by HSI).
	RAM	-	12 Kbytes starting from address 0x20000000 are used by the bootloader firmware
	System memory	-	28 Kbytes starting from address 0x1FFF0000, contain the bootloader firmware
	IWDG	-	The independent watchdog (IWDG) prescaler is configured to its maximum value. It is periodically refreshed to prevent watchdog reset (in case the hardware IWDG option was previously enabled by the user).
Securable memory area	-	-	The address to jump to for the securable memory area: @0x1FFF6800
USART1 bootloader	USART1	Enabled	Once initialized the USART1 configuration is: 8-bit, even parity and 1 Stop bit
	USART1_RX pin	Input	PA10 pin: USART1 in reception mode
	USART1_TX pin	Output	PA9 pin: USART1 in transmission mode
USART2 bootloader	USART2	Enabled	Once initialized the USART2 configuration is: 8-bit, even parity and 1 Stop bit
	USART2_RX pin	Input	PA3 pin: USART2 in reception mode
	USART2_TX pin	Output	PA2 pin: USART2 in transmission mode
USART3 bootloader	USART3	Enabled	Once initialized the USART3 configuration is: 8-bit, even parity and 1 Stop bit
	USART3_RX pin	Input	PC11 pin: USART3 in reception mode
	USART3_TX pin	Output	PC10 pin: USART3 in transmission mode
I2C1 bootloader	I2C1	Enabled	The I2C1 configuration is: I2C speed: up to 1 MHz, 7-bit address, slave mode, analog filter ON. Slave 7-bit address: 0b1010001x (where x = 0 for write and x = 1 for read)
	I2C1_SCL pin	Input/Output	PB6 pin: clock line is used in open-drain mode.
	I2C1_SDA pin	Input/Output	PB7 pin: data line is used in open-drain mode.

Table 87. STM32G07xxx/8xxx configuration in system memory boot mode (continued)

Bootloader	Feature/Peripheral	State	Comment
I2C2 bootloader	I2C2	Enabled	The I2C2 configuration is: I2C speed: up to 1 MHz, 7-bit address, slave mode, analog filter ON. Slave 7-bit address: 0b1010001x (where x = 0 for write and x = 1 for read)
	I2C2_SCL pin	Input/Output	PB10 pin: clock line is used in open-drain mode.
	I2C2_SDA pin	Input/Output	PB11 pin: data line is used in open-drain mode.
SPI1 bootloader	SPI1	Enabled	The SPI1 configuration is: – Slave mode – Full Duplex – 8-bit MSB – Speed up to 8 MHz – Polarity: CPOL Low, CPHA Low, NSS hardware.
	SPI1_MOSI pin	Input	PA7 pin: Slave data Input line, used in push-pull, pull-down mode.
	SPI1_MISO pin	Output	PA6 pin: Slave data output line, used in push-pull, pull-down mode.
	SPI1_SCK pin	Input	PA5 pin: Slave clock line, used in push-pull, pull-down mode.
	SPI1_NSS pin	Input	PA4 pin: slave chip select pin used in push-pull, pull-down mode. Note: This IO can be tied to GND if the SPI Master does not use it.
SPI2 bootloader	SPI2	Enabled	The SPI2 configuration is: – Slave mode – Full Duplex – 8-bit MSB – Speed up to 8 MHz – Polarity: CPOL Low, CPHA Low, NSS hardware.
	SPI2_MOSI pin	Input	PB15 pin: Slave data Input line, used in push-pull, pull-down mode.
	SPI2_MISO pin	Output	PB14 pin: Slave data output line, used in push-pull, pull-down mode.
	SPI2_SCK pin	Input	PB13 pin: Slave clock line, used in push-pull, pull-down mode.
	SPI2_NSS pin	Input	PB12 pin: slave chip select pin used in push-pull, pull-down. Note: This IO can be tied to GND if the SPI master does not use it.

40.2 Bootloader selection

Figure 51 shows the bootloader selection mechanism.

Figure 51. Bootloader V11.0 selection for STM32G07xxx/G08xxx

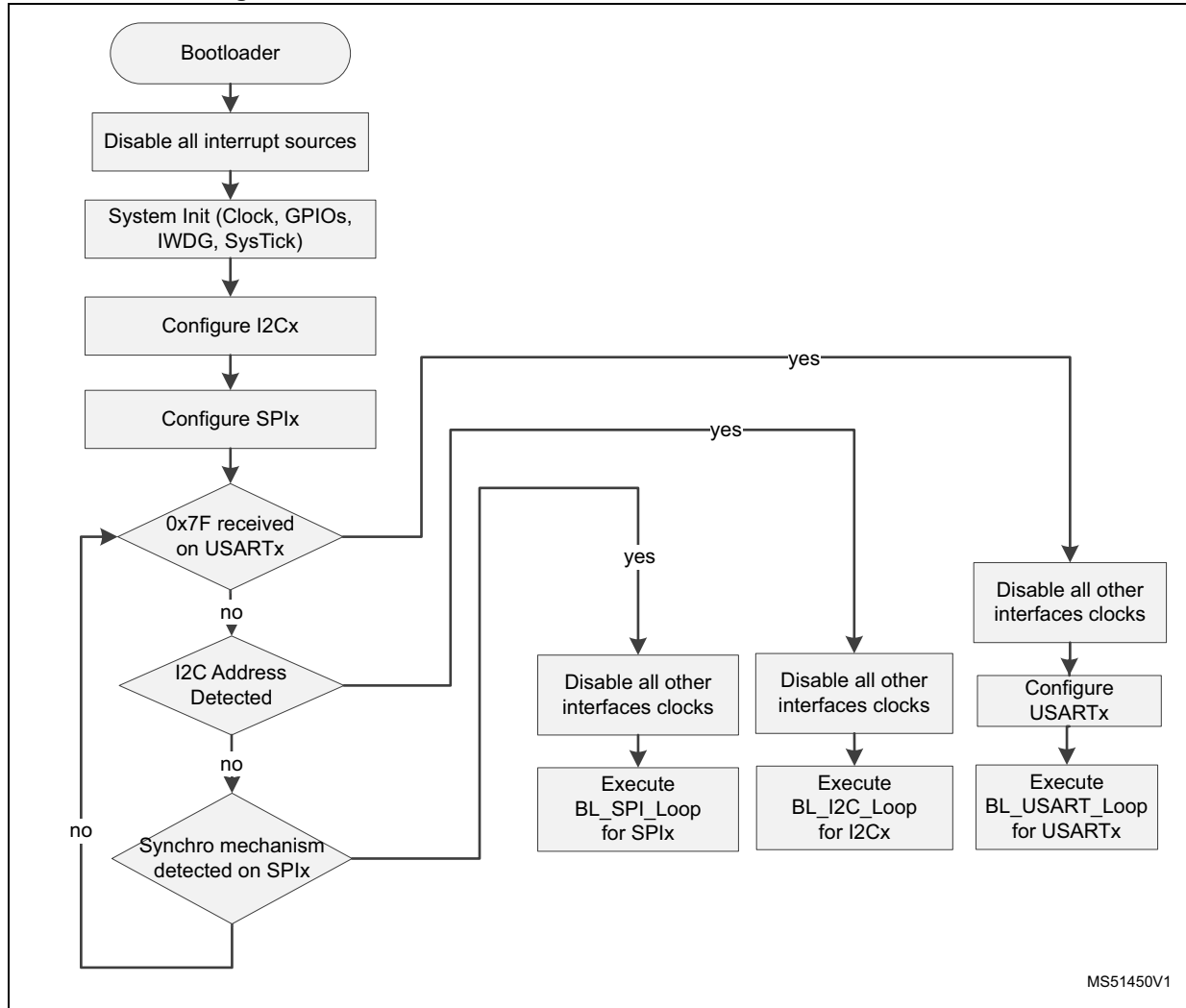

40.3 Bootloader version

Table 88 lists the STM32G07xxx/8xxx devices bootloader versions.

Table 88. STM32G07xx/08xxx bootloader versions

Bootloader version number	Description	Known limitations
V11.0	Initial bootloader version	Not supporting packages smaller than LQFP64
V11.1	Supporting all packages	None
V11.2	Add securable memory area feature	None

41 STM32G0B0xx device bootloader

41.1 Bootloader configuration

The STM32G0B0xx bootloader is activated by applying Pattern 10 (described in [Table 2: Bootloader activation patterns](#)). The following table shows the hardware resources used by this bootloader.

Table 89. STM32G0B0xx configuration in system memory boot mode

Bootloader	Feature/Peripheral	State	Comment
Common to all bootloaders	RCC	HSI enabled	The system clock frequency is 60 MHz (using PLL clocked by HSI). If an external clock (HSE) is not present, the system is kept clocked from the HSI
		HSE enabled	The external clock can be used for all bootloader interfaces and must have one of the following values [48, 32, 16, 12, 8] MHz. The PLL is used to generate 48 MHz for USB and system clock.
	RAM	-	16 Kbytes starting from address 0x20000000 are used by the bootloader firmware
	System memory	-	The bootloader firmware is shared on two banks: - 28 Kbyte starting from address 0x1FFF0000 until 0x1FFF6FFF - Part of the 28 KB (0x1FFF8000 – 0x1FFFEFFF)
	IWDG	-	The independent watchdog (IWDG) prescaler is configured to its maximum value. It is periodically refreshed to prevent watchdog reset (in case the hardware IWDG option was previously enabled by the user).
Securable memory area	-	-	The address to jump to for the exit securable memory area: @0x1FFF6800
USART1 bootloader	USART1	Enabled	Once initialized the USART1 configuration is: 8-bit, even parity and 1 Stop bit
	USART1_RX pin	Input	PA10 pin: USART1 in reception mode
	USART1_TX pin	Output	PA9 pin: USART1 in transmission mode
USART2 bootloader	USART2	Enabled	Once initialized the USART2 configuration is: 8-bit, even parity and 1 Stop bit
	USART2_RX pin	Input	PA3 pin: USART2 in reception mode
	USART2_TX pin	Output	PA2 pin: USART2 in transmission mode
USART3 bootloader	USART3	Enabled	Once initialized the USART3 configuration is: 8-bit, even parity and 1 Stop bit
	USART3_RX pin	Input	PC11 pin: USART3 in reception mode
	USART3_TX pin	Output	PC10 pin: USART3 in transmission mode

Table 89. STM32G0B0xx configuration in system memory boot mode (continued)

Bootloader	Feature/Peripheral	State	Comment
I2C1 bootloader	I2C1	Enabled	The I2C1 configuration is: I2C speed: up to 1 MHz, 7-bit address, slave mode, analog filter ON. Slave 7-bit address: 0b1011101x (where x = 0 for write and x = 1 for read)
	I2C1_SCL pin	Input/Output	PB6 pin: clock line is used in open-drain mode.
	I2C1_SDA pin	Input/Output	PB7 pin: data line is used in open-drain mode.
I2C2 bootloader	I2C2	Enabled	The I2C2 configuration is: I2C speed: up to 1 MHz, 7-bit address, slave mode, analog filter ON. Slave 7-bit address: 0b1011101x (where x = 0 for write and x = 1 for read)
	I2C2_SCL pin	Input/Output	PB10 pin: clock line is used in open-drain mode.
	I2C2_SDA pin	Input/Output	PB11 pin: data line is used in open-drain mode.
SPI1 bootloader	SPI1	Enabled	The SPI1 configuration is: – Slave mode – Full Duplex – 8-bit MSB – Speed up to 8 MHz – Polarity: CPOL Low, CPHA Low, NSS hardware.
	SPI1_MOSI pin	Input	PA7 pin: Slave data Input line, used in push-pull, pull-down mode.
	SPI1_MISO pin	Output	PA6 pin: Slave data output line, used in push-pull, pull-down mode.
	SPI1_SCK pin	Input	PA5 pin: Slave clock line, used in push-pull, pull-down mode.
	SPI1_NSS pin	Input	PA4 pin: slave chip select pin used in push-pull, pull-down mode. Note: This IO can be tied to GND if the SPI Master does not use it.

Table 89. STM32G0B0xx configuration in system memory boot mode (continued)

Bootloader	Feature/Peripheral	State	Comment
SPI2 bootloader	SPI2	Enabled	The SPI2 configuration is: – Slave mode – Full Duplex – 8-bit MSB – Speed up to 8 MHz – Polarity: CPOL Low, CPHA Low, NSS hardware.
	SPI2_MOSI pin	Input	PB15 pin: Slave data Input line, used in push-pull, pull-down mode.
	SPI2_MISO pin	Output	PB14 pin: Slave data output line, used in push-pull, pull-down mode.
	SPI2_SCK pin	Input	PB13 pin: Slave clock line, used in push-pull, pull-down mode.
	SPI2_NSS pin	Input	PB12 pin: slave chip select pin used in push-pull, pull-down. Note: This IO can be tied to GND if the SPI master does not use it.
DFU bootloader	USB	Enabled	USB FS configured in Forced Device mode. USB FS interrupt vector is enabled and used for USB DFU communications. Note: VDDUSB IO must be connected to 3.3 V as USB peripheral is used by the bootloader.'
	USB_DM pin	Input/Output	PA11: USB DM line.
	USB_DP pin		PA12: USB DP line No external pull-up resistor is required

41.2 Bootloader selection

The figure below shows the bootloader selection mechanism.

Figure 52. Bootloader selection for STM32G0B0xx

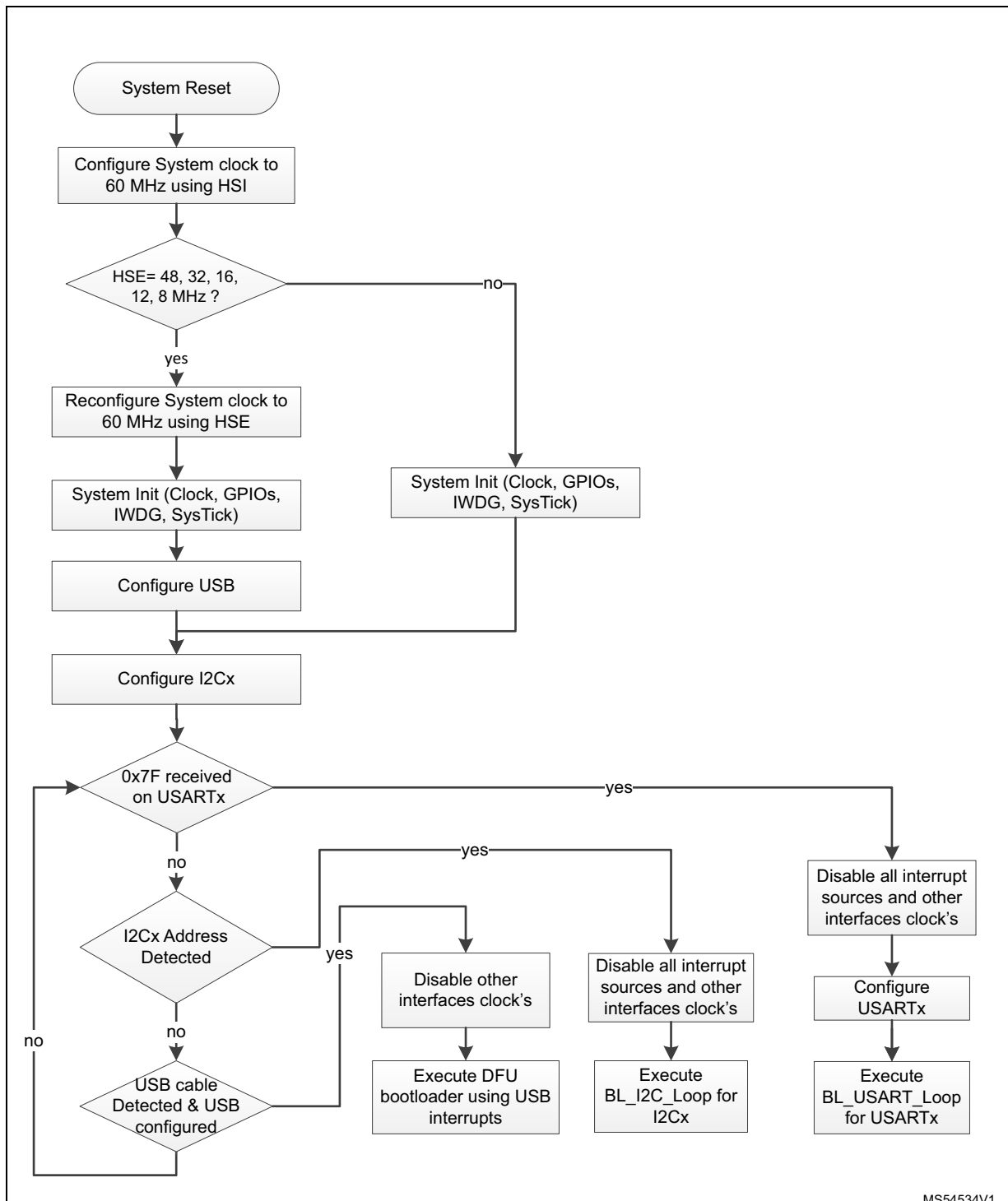

MS54534V1

41.3 Bootloader version

[Table 90](#) lists the STM32G0B0xx devices bootloader versions.

Table 90. STM32G0B0xx bootloader versions

Bootloader version number	Description	known limitations
V13.0	Initial bootloader version	None

42 STM32G0B1xx/0C1xx device bootloader

42.1 Bootloader configuration

The STM32G0B1xx/0C1xx bootloader is activated by applying Pattern 10 (described in [Table 2: Bootloader activation patterns](#)). The following table shows the hardware resources used by this bootloader.

Table 91. STM32G0B1xx/0C1xx configuration in system memory boot mode

Bootloader	Feature/Peripheral	State	Comment
Common to all bootloaders	RCC	HSI enabled	The system clock frequency is 60 MHz (using PLL clocked by HSI).
		-	The clock recovery system (CRS) is enabled for the DFU bootloader to allow USB to be clocked by HSI48 48 MHz.
		-	20 MHz derived from the PLLQ is used for FDCAN
	RAM	-	16 Kbytes starting from address 0x20000000 are used by the bootloader firmware
	System memory	-	The bootloader firmware is shared on two banks: - 28 Kbyte starting from address 0x1FFF0000 until 0x1FFF6FFF - Part of the 28 KB (0x1FFF8000 – 0x1FFFEFFF)
IWDG	-	The independent watchdog (IWDG) prescaler is configured to its maximum value. It is periodically refreshed to prevent watchdog reset (in case the hardware IWDG option was previously enabled by the user).	
Securable memory area	-	-	The address to jump to for the securable memory area: @0x1FFF6800
USART1 bootloader	USART1	Enabled	Once initialized the USART1 configuration is: 8-bit, even parity and 1 Stop bit
	USART1_RX pin	Input	PA10 pin: USART1 in reception mode
	USART1_TX pin	Output	PA9 pin: USART1 in transmission mode
USART2 bootloader	USART2	Enabled	Once initialized the USART2 configuration is: 8-bit, even parity and 1 Stop bit
	USART2_RX pin	Input	PA3 pin: USART2 in reception mode
	USART2_TX pin	Output	PA2 pin: USART2 in transmission mode
USART3 bootloader	USART3	Enabled	Once initialized the USART3 configuration is: 8-bit, even parity and 1 Stop bit
	USART3_RX pin	Input	PC11 pin: USART3 in reception mode
	USART3_TX pin	Output	PC10 pin: USART3 in transmission mode

Table 91. STM32G0B1xx/0C1xx configuration in system memory boot mode (continued)

Bootloader	Feature/Peripheral	State	Comment
I2C2 bootloader	I2C2	Enabled	The I2C1 configuration is: I2C speed: up to 1 MHz, 7-bit address, slave mode, analog filter ON. Slave 7-bit address: 0b1011101x (where x = 0 for write and x = 1 for read)
	I2C2_SCL pin	Input/Output	PB6 pin: clock line is used in open-drain mode.
	I2C2_SDA pin	Input/Output	PB7 pin: data line is used in open-drain mode.
I2C3 bootloader	I2C3	Enabled	The I2C3 configuration is: I2C speed: up to 1 MHz, 7-bit address, slave mode, analog filter ON. Slave 7-bit address: 0b1011101x (where x = 0 for write and x = 1 for read)
	I2C3_SCL pin	Input/Output	PB10 pin: clock line is used in open-drain mode.
	I2C3_SDA pin	Input/Output	PB11 pin: data line is used in open-drain mode.
SPI1 bootloader	SPI1	Enabled	The SPI1 configuration is: – Slave mode – Full Duplex – 8-bit MSB – Speed up to 8 MHz – Polarity: CPOL Low, CPHA Low, NSS hardware.
	SPI1_MOSI pin	Input	PA7 pin: Slave data Input line, used in push-pull, pull-down mode.
	SPI1_MISO pin	Output	PA6 pin: Slave data output line, used in push-pull, pull-down mode.
	SPI1_SCK pin	Input	PA5 pin: Slave clock line, used in push-pull, pull-down mode.
	SPI1_NSS pin	Input	PA4 pin: slave chip select pin used in push-pull, pull-down mode. Note: This IO can be tied to GND if the SPI Master does not use it.

Table 91. STM32G0B1xx/0C1xx configuration in system memory boot mode (continued)

Bootloader	Feature/Peripheral	State	Comment
SPI2 bootloader	SPI2	Enabled	The SPI2 configuration is: <ul style="list-style-type: none"> – Slave mode – Full Duplex – 8-bit MSB – Speed up to 8 MHz – Polarity: CPOL Low, CPHA Low, NSS hardware.
	SPI2_MOSI pin	Input	PB15 pin: Slave data Input line, used in push-pull, pull-down mode.
	SPI2_MISO pin	Output	PB14 pin: Slave data output line, used in push-pull, pull-down mode.
	SPI2_SCK pin	Input	PB13 pin: Slave clock line, used in push-pull, pull-down mode.
	SPI2_NSS pin	Input	PB12 pin: slave chip select pin used in push-pull, pull-down. Note: This IO can be tied to GND if the SPI master does not use it.
DFU bootloader	USB	Enabled	USB FS configured in Forced Device mode. USB FS interrupt vector is enabled and used for USB DFU communications. Note: VDDUSB IO must be connected to 3.3 V as USB peripheral is used by the bootloader.'
	USB_DM pin	Input/Output	PA11: USB DM line.
	USB_DP pin		PA12: USB DP line No external pull-up resistor is required
FDCAN	FDCAN1	Enabled	Once initialized the FDCAN1 configuration is: <ul style="list-style-type: none"> – - bit-rate 0.5 Mbps – - FrameFormat = FDCAN_FRAME_FD_BRS Mode = FDCAN_MODE_NORMAL – - AutoRetransmission = ENABLE – - TransmitPause = DISABLE – - ProtocolException = ENABLE
	FDCAN1_Rx pin	Input	PD0 pin: FDCAN1 in reception mode
	FSDCAN1_Tx pin	Output	PD0 pin: FDCAN1 in transmission mode

42.2 Bootloader selection

The figure below shows the bootloader selection mechanism.

Figure 53. Bootloader selection for STM32G0B1xx/0C1xx

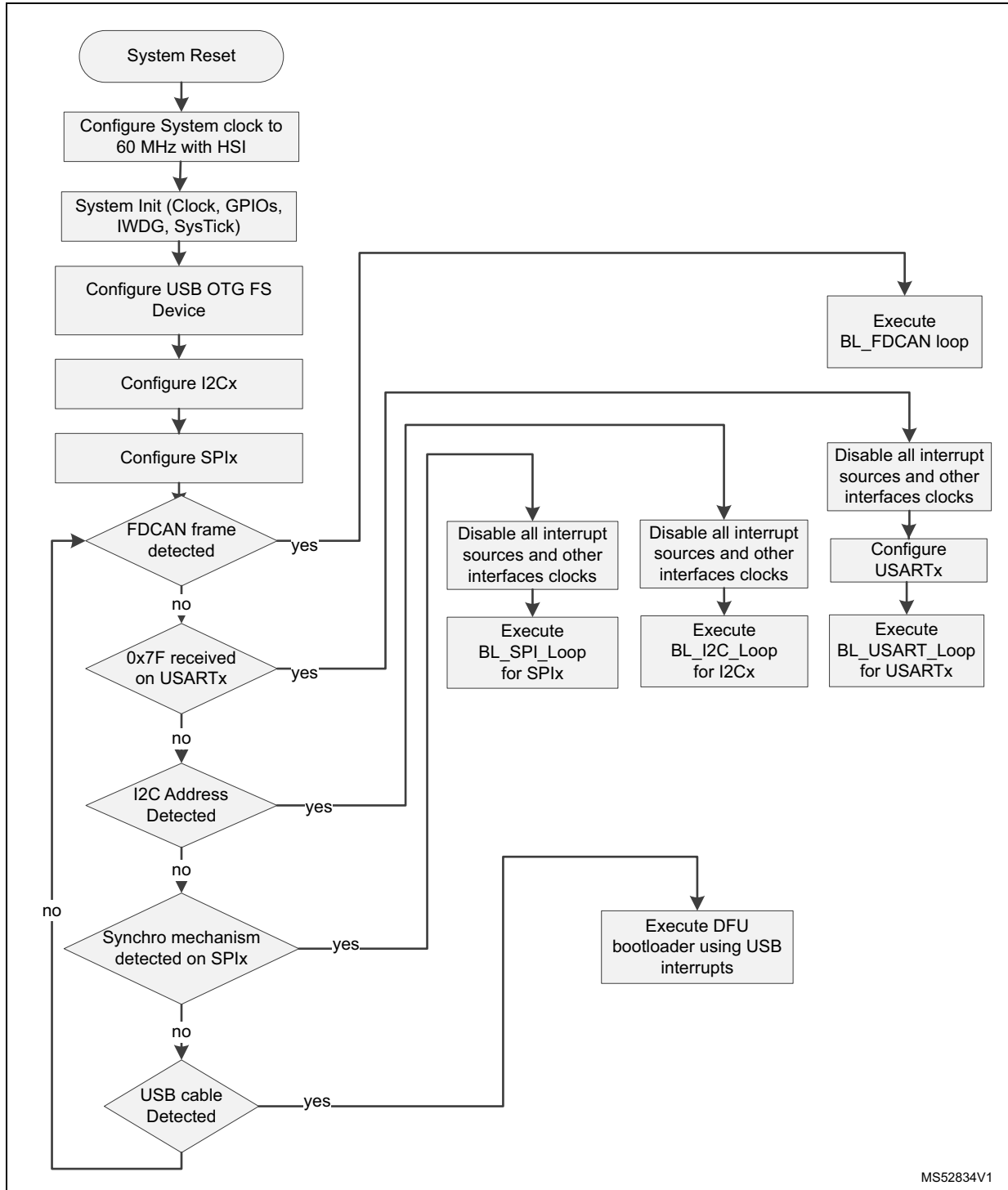

42.3 Bootloader version

Table 18 lists the STM32G0B1xx/0C1xx devices bootloader versions.

Table 92. STM32G0B1xx/0C1xx bootloader versions

Bootloader version number	Description	known limitations
V9.2	Initial bootloader version	None

43 STM32G431xx/441xx devices bootloader

43.1 Bootloader configuration

The STM32G431xx/441xx bootloader is activated by applying Pattern 15 (described in [Table 2: Bootloader activation patterns](#)). The following table shows the hardware resources used by this bootloader.

Table 93. STM32G431xx/441xx configuration in system memory boot mode

Bootloader	Feature/Peripheral	State	Comment
Common to all bootloaders	RCC	HSI enabled	The system clock frequency is 72 MHz (using the PLL clocked by HSI)
		-	The clock recovery system (CRS) is enabled for the DFU bootloader to allow USB to be clocked by HSI48 48 MHz
	RAM	-	16 Kbyte starting from address 0x20000000 are used by the bootloader firmware
	System memory	-	28 Kbyte starting from address 0x1FFF0000, contain the bootloader firmware
	IWDG	-	The independent watchdog (IWDG) prescaler is configured to its maximum value. It is periodically refreshed to prevent watchdog reset (in case the hardware IWDG option was previously enabled by the user).
Securable memory area	-	-	The address to jump to the exit securable memory area @0x1FFF6800
USART1 bootloader	USART1	Enabled	Once initialized the USART1 configuration is: 8-bit, even parity and 1 Stop bit
	USART1_RX pin	Input	PA10 pin: USART1 in reception mode
	USART1_TX pin	Output	PA9 pin: USART1 in transmission mode
USART2 bootloader	USART2	Enabled	Once initialized the USART2 configuration is: 8-bit, even parity and 1 Stop bit
	USART2_RX pin	Input	PA3 pin: USART2 in reception mode
	USART2_TX pin	Output	PA2 pin: USART2 in transmission mode
USART3 bootloader	USART3	Enabled	Once initialized the USART3 configuration is: 8-bit, even parity and 1 Stop bit
	USART3_RX pin	Input	PC11 pin: USART3 in reception mode
	USART3_TX pin	Output	PC10 pin: USART3 in transmission mode

Table 93. STM32G431xx/441xx configuration in system memory boot mode (continued)

Bootloader	Feature/Peripheral	State	Comment
I2C2 bootloader	I2C2	Enabled	The I2C2 configuration is: I2C speed: up to 1 MHz, 7-bit address, slave mode, analog filter ON. Slave 7-bit address: 0b1010100x (where x = 0 for write and x = 1 for read)
	I2C2_SCL pin	Input/Output	PC4 pin: clock line is used in open-drain mode.
	I2C2_SDA pin	Input/Output	PA8 pin: data line is used in open-drain mode.
I2C3 bootloader	I2C3	Enabled	The I2C3 configuration is: I2C speed: up to 1 MHz, 7-bit address, slave mode, analog filter ON. Slave 7-bit address: 0b1010100x (where x = 0 for write and x = 1 for read)
	I2C3_SCL pin	Input/Output	PC8 pin: clock line is used in open-drain mode.
	I2C3_SDA pin	Input/Output	PC9 pin: data line is used in open-drain mode.
SPI1 bootloader	SPI1	Enabled	The SPI1 configuration is: – Slave mode – Full Duplex – 8-bit MSB – Speed up to 8 MHz – Polarity: CPOL Low, CPHA Low, NSS hardware.
	SPI1_MOSI pin	Input	PA7 pin: Slave data Input line, used in push-pull, pull-down mode.
	SPI1_MISO pin	Output	PA6 pin: Slave data output line, used in push-pull, pull-down mode.
	SPI1_SCK pin	Input	PA5 pin: Slave clock line, used in push-pull, pull-down mode.
	SPI1_NSS pin	Input	PA4 pin: slave chip select pin used in push-pull, pull-down mode.

Table 93. STM32G431xx/441xx configuration in system memory boot mode (continued)

Bootloader	Feature/Peripheral	State	Comment
SPI2 bootloader	SPI2	Enabled	The SPI2 configuration is: – Slave mode – Full Duplex – 8-bit MSB – Speed up to 8 MHz – Polarity: CPOL Low, CPHA Low, NSS hardware.
	SPI2_MOSI pin	Input	PB15 pin: Slave data Input line, used in push-pull, pull-down mode.
	SPI2_MISO pin	Output	PB14 pin: Slave data output line, used in push-pull, pull-down mode.
	SPI2_SCK pin	Input	PB13 pin: Slave clock line, used in push-pull, pull-down mode.
	SPI2_NSS pin	Input	PB12 pin: slave chip select pin used in push-pull, pull-down mode. Note: This IO can be tied to GND if the SPI Master does not use it.
DFU bootloader	USB	Enabled	USB FS configured in forced device mode. USB FS interrupt vector is enabled and used for USB DFU communications.
	USB_DM pin	Input/Output	PA11: USB DM line.
	USB_DP pin		PA12: USB DP line No external pull-up resistor is required

43.2 Bootloader selection

The figure below shows the bootloader selection mechanism.

Figure 54. Bootloader selection for STM32G431xx/441xx

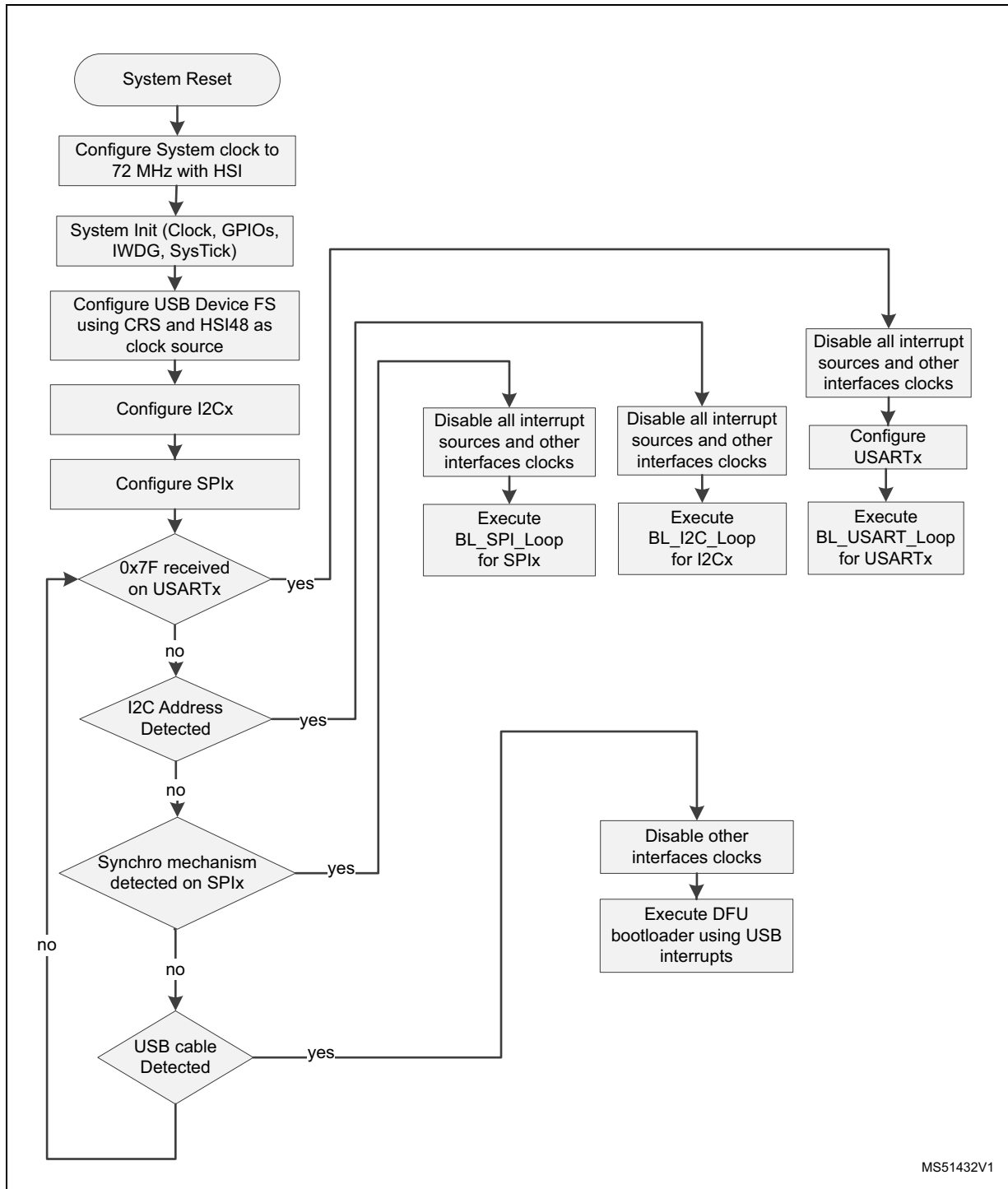

43.3 Bootloader version

Table 94. STM32G431xx/441xx bootloader version

Bootloader version number	Description	Known limitations
V13.3 (0xD3)	Initial bootloader version	CCSRAM not supported
V13.4 (0xD4)	Fix V13.3 limitations	Add CCSRAM support

44 STM32G47xxx/48xxx devices bootloader

44.1 Bootloader configuration

The STM32G47xxx/48xxx bootloader is activated by applying Pattern 14 (described in [Table 2: Bootloader activation patterns](#)). The following table shows the hardware resources used by this bootloader.

Table 95. STM32G47xxx/48xxx configuration in system memory boot mode

Bootloader	Feature/Peripheral	State	Comment
Common to all bootloaders	RCC	HSI enabled	The system clock frequency is 72 MHz (using the PLL clocked by HSI)
		-	The clock recovery system (CRS) is enabled for the DFU bootloader to allow USB to be clocked by HSI48 48 MHz
	RAM	-	16 Kbyte starting from address 0x20000000 are used by the bootloader firmware
	System memory	-	28 Kbyte starting from address 0x1FFF0000, contain the bootloader firmware
	IWDG	-	The independent watchdog (IWDG) prescaler is configured to its maximum value. It is periodically refreshed to prevent watchdog reset (in case the hardware IWDG option was previously enabled by the user).
Securable memory area	-	-	The address to jump to the exit securable memory area @0x1FFF6800
USART1 bootloader	USART1	Enabled	Once initialized the USART1 configuration is: 8-bit, even parity and 1 Stop bit
	USART1_RX pin	Input	PA10 pin: USART1 in reception mode
	USART1_TX pin	Output	PA9 pin: USART1 in transmission mode
USART2 bootloader	USART2	Enabled	Once initialized the USART2 configuration is: 8-bit, even parity and 1 Stop bit
	USART2_RX pin	Input	PA3 pin: USART2 in reception mode
	USART2_TX pin	Output	PA2 pin: USART2 in transmission mode
USART3 bootloader	USART3	Enabled	Once initialized the USART3 configuration is: 8-bit, even parity and 1 Stop bit
	USART3_RX pin	Input	PC11 pin: USART3 in reception mode
	USART3_TX pin	Output	PC10 pin: USART3 in transmission mode

Table 95. STM32G47xxx/48xxx configuration in system memory boot mode (continued)

Bootloader	Feature/Peripheral	State	Comment
I2C2 bootloader	I2C2	Enabled	The I2C2 configuration is: I2C speed: up to 1 MHz, 7-bit address, slave mode, analog filter ON. Slave 7-bit address: 0b1010011x (where x = 0 for write and x = 1 for read)
	I2C2_SCL pin	Input/Output	PC4 pin: clock line is used in open-drain mode.
	I2C2_SDA pin	Input/Output	PA8 pin: data line is used in open-drain mode.
I2C3 bootloader	I2C3	Enabled	The I2C3 configuration is: I2C speed: up to 1 MHz, 7-bit address, slave mode, analog filter ON. Slave 7-bit address: 0b1010011x (where x = 0 for write and x = 1 for read)
	I2C3_SCL pin	Input/Output	PC8 pin: clock line is used in open-drain mode.
	I2C3_SDA pin	Input/Output	PC9 pin: data line is used in open-drain mode.
I2C4 bootloader	I2C4	Enabled	The I2C4 configuration is: I2C speed: up to 1 MHz, 7-bit address, slave mode, analog filter ON. Slave 7-bit address: 0b1010011x (where x = 0 for write and x = 1 for read)
	I2C4_SCL pin	Input/Output	PC6 pin: clock line is used in open-drain mode.
	I2C4_SDA pin	Input/Output	PC7 pin: data line is used in open-drain mode.
SPI1 bootloader	SPI1	Enabled	The SPI1 configuration is: – Slave mode – Full Duplex – 8-bit MSB – Speed up to 8 MHz – Polarity: CPOL Low, CPHA Low, NSS hardware.
	SPI1_MOSI pin	Input	PA7 pin: Slave data Input line, used in push-pull, pull-down mode.
	SPI1_MISO pin	Output	PA6 pin: Slave data output line, used in push-pull, pull-down mode.
	SPI1_SCK pin	Input	PA5 pin: Slave clock line, used in push-pull no pull-up, pull-down mode.
	SPI1_NSS pin	Input	PA4 pin: slave chip select pin used in push-pull, pull-down mode.

Table 95. STM32G47xxx/48xxx configuration in system memory boot mode (continued)

Bootloader	Feature/Peripheral	State	Comment
SPI2 bootloader	SPI2	Enabled	The SPI2 configuration is: – Slave mode – Full Duplex – 8-bit MSB – Speed up to 8 MHz – Polarity: CPOL Low, CPHA Low, NSS hardware.
	SPI2_MOSI pin	Input	PB15 pin: Slave data Input line, used in push-pull, npull-down mode.
	SPI2_MISO pin	Output	PB14 pin: Slave data output line, used in push-pull, pull-down mode.
	SPI2_SCK pin	Input	PB13 pin: Slave clock line, used in push-pull, n pull-down mode.
	SPI2_NSS pin	Input	PB12 pin: slave chip select pin used in push-pull, pull-down mode. Note: This IO can be tied to GND if the SPI Master does not use it.
DFU bootloader	USB	Enabled	USB FS configured in forced device mode. USB FS interrupt vector is enabled and used for USB DFU communications. Note: VDDUSB IO must be connected to 3.3 V as USB peripheral is used by the bootloader.
	USB_DM pin	Input/Output	PA11: USB DM line.
	USB_DP pin		PA12: USB DP line No external pull-up resistor is required

44.2 Bootloader selection

The figures below show the bootloader selection mechanism.

Figure 55. Bootloader selection for STM32G47xxx/48xxx

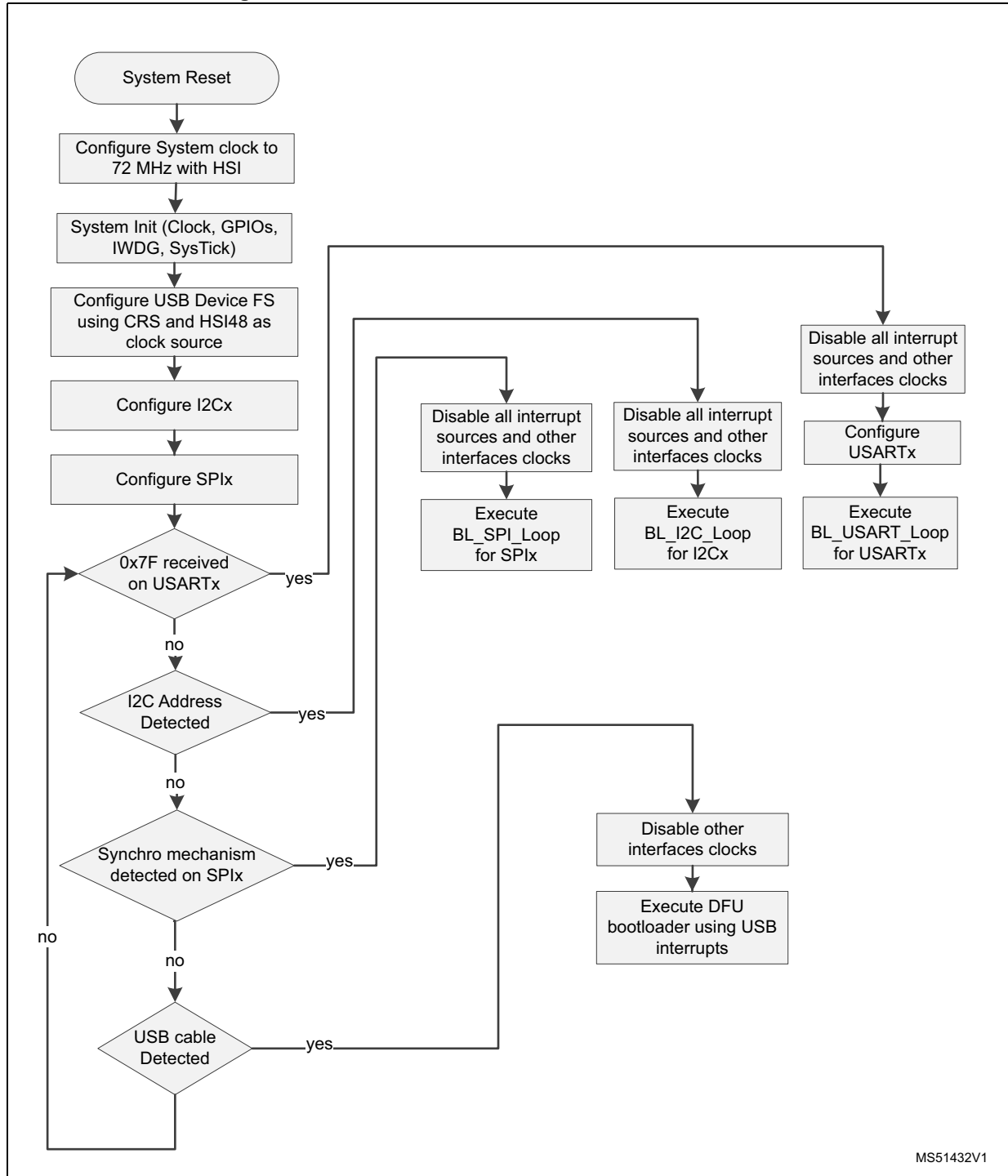
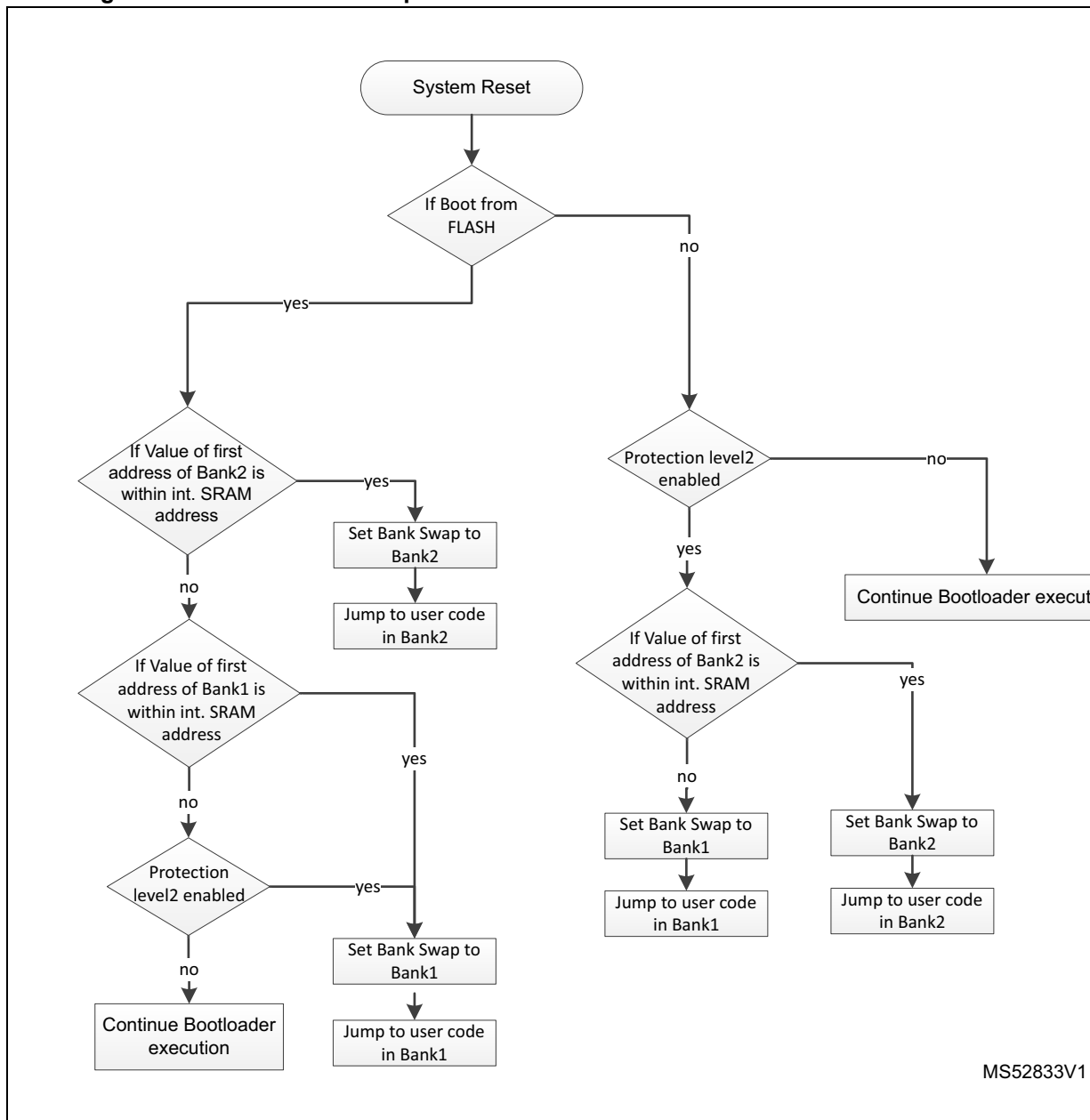

Figure 56. Dual bank boot implementation for STM32G47xxx/48xxx bootloader V13.x



44.3 Bootloader version

Table 96. STM32G47xxx/48xxx bootloader version

Bootloader version number	Description	Known limitations
V13.3 (0xD3)	Initial bootloader version	Boot from bank2 is not working
V13.4 (0xD4)	Fix V13.3 limitations	CCSRAM not supported
V13.5 (0xD5)	Fix V13.4 limitations	Add CCSRAM support

45 STM32H72xxx/73xxx devices bootloader

45.1 Bootloader configuration

The STM32H72xxx/73xxx bootloader is activated by applying Pattern 10 (described in [Table 2: Bootloader activation patterns](#)). [Table 97](#) shows the hardware resources used by this bootloader.

Table 97. STM32H72xxx/73xxx configuration in system memory boot mode

Bootloader	Feature/Peripheral	State	Comment
Common to all bootloaders	RCC	HSI enabled	The system clock frequency is 66 MHz (using PLL clocked by the HSI)
		-	The clock recovery system (CRS) is enabled for the DFU bootloader to allow USB to be clocked by HSI48 48 MHz
		-	20 MHz derived from the PLLQ is used for FDCAN
	RAM	-	16 Kbyte starting from address 0x24000000 are used by the bootloader firmware
	System memory	-	84 Kbyte starting from address 0x1FFF9800 contain the bootloader firmware
	IWDG	-	The independent watchdog (IWDG) prescaler is configured to its maximum value. It is periodically refreshed to prevent watchdog reset (in case the hardware IWDG option was previously enabled by the user).
	Power	-	Voltage range is set to Voltage Range 3.
USART1 bootloader	USART1	Enabled	Once initialized the USART1 configuration is: 8-bit, even parity and 1 Stop bit
	USART1_RX pin	Input	PA10 pin: USART1 in reception mode
	USART1_TX pin	Output	PA9 pin: USART1 in transmission mode
USART2 bootloader	USART2	Enabled	Once initialized the USART2 configuration is: 8-bit, even parity and 1 Stop bit
	USART2_RX pin	Input	PA3 pin: USART2 in reception mode
	USART2_TX pin	Output	PA2 pin: USART2 in transmission mode
USART3 bootloader (on PB10/PB11)	USART3	Enabled	Once initialized the USART3 configuration is: 8-bit, even parity and 1 Stop bit
	USART3_RX pin	Input	PB11 pin: USART3 in reception mode
	USART3_TX pin	Output	PB10 pin: USART3 in transmission mode
USART3 bootloader (on PD8/PD9)	USART3	Enabled	Once initialized the USART3 configuration is: 8-bit, even parity and 1 Stop bit
	USART3_RX pin	Input	PD9 pin: USART3 in reception mode
	USART3_TX pin	Output	PD8 pin: USART3 in transmission mode

Table 97. STM32H72xxx/73xxx configuration in system memory boot mode (continued)

Bootloader	Feature/Peripheral	State	Comment
I2C1 bootloader	I2C1	Enabled	The I2C1 configuration is: I2C speed: up to 1 MHz, 7-bit address, slave mode, analog filter ON. Slave 7-bit address: 0b1010111x (where x = 0 for write and x = 1 for read)
	I2C1_SCL pin	Input/Output	PB6 pin: clock line is used in open-drain mode.
	I2C1_SDA pin	Input/Output	PB9 pin: data line is used in open-drain mode.
I2C2 bootloader	I2C2	Enabled	The I2C2 configuration is: I2C speed: up to 1 MHz, 7-bit address, slave mode, analog filter ON. Slave 7-bit address: 0b1010111x (where x = 0 for write and x = 1 for read)
	I2C2_SCL pin	Input/Output	PF1 pin: clock line is used in open-drain mode.
	I2C2_SDA pin	Input/Output	PF0 pin: data line is used in open-drain mode.
I2C3 bootloader	I2C3	Enabled	The I2C3 configuration is: I2C speed: up to 1 MHz, 7-bit address, slave mode, analog filter ON. Slave 7-bit address: 0b1010111x (where x = 0 for write and x = 1 for read)
	I2C3_SCL pin	Input/Output	PA8 pin: clock line is used in open-drain mode.
	I2C3_SDA pin	Input/Output	PC9 pin: data line is used in open-drain mode.
SPI1 bootloader	SPI1	Enabled	The SPI1 configuration is: – Slave mode – Full Duplex – 8-bit MSB – Speed up to 8 MHz – Polarity: CPOL Low, CPHA Low, NSS hardware.
	SPI1_MOSI pin	Input	PA7 pin: Slave data Input line, used in push-pull, pull-down mode.
	SPI1_MISO pin	Output	PA6 pin: Slave data output line, used in push-pull, pull-down mode.
	SPI1_SCK pin	Input	PA5 pin: Slave clock line, used in push-pull, pull-down mode.
	SPI1_NSS pin	Input	PA4 pin: slave chip select pin used in push-pull, pull-down mode.

Table 97. STM32H72xxx/73xxx configuration in system memory boot mode (continued)

Bootloader	Feature/Peripheral	State	Comment
SPI3 bootloader	SPI3	Enabled	The SPI3 configuration is: – Slave mode – Full Duplex – 8-bit MSB – Speed up to 8 MHz – Polarity: CPOL Low, CPHA Low, NSS hardware.
	SPI3_MOSI pin	Input	PC12 pin: Slave data Input line, used in push-pull pull down mode
	SPI3_MISO pin	Output	PC11 pin: Slave data output line, used in push-pull pull down mode.
	SPI3_SCK pin	Input	PC10 pin: Slave clock line, used in push-pull pull down mode.
	SPI3_NSS pin	Input	PA15 pin: slave chip select pin used in push-pull, pull-down mode.
DFU bootloader	USB	Enabled	USB FS configured in forced device mode. USB FS interrupt vector is enabled and used for USB DFU communications.
	USB_DM pin	Input/Output	PA11: USB DM line.
	USB_DP pin		PA12: USB DP line No external pull-up resistor is required
FDCAN bootloader (on PH13/PH14)	FDCAN1	Enabled	Once initialized the FDCAN1 configuration is: bit-rate 0.5 Mbps FrameFormat = FDCAN_FRAME_FD_BRS Mode = FDCAN_MODE_NORMAL AutoRetransmission = ENABLE TransmitPause = DISABLE ProtocolException = ENABLE
	FDCAN1_Rx pin	Input	PH14 pin: FDCAN1 in reception mode
	FDCAN1_Tx pin	Output	PH13 pin: FDCAN1 in transmission mode
FDCAN bootloader (onPD1/PD0)	FDCAN1	Enabled	Once initialized the FDCAN1 configuration is: bit-rate 0.5 Mbps FrameFormat = FDCAN_FRAME_FD_BRS Mode = FDCAN_MODE_NORMAL AutoRetransmission = ENABLE TransmitPause = DISABLE ProtocolException = ENABLE
	FDCAN1_Rx pin	Input	PD0 pin: FDCAN1 in reception mode
	FDCAN1_Tx pin	Output	PD1 pin: FDCAN1 in transmission mode

45.2 Bootloader selection

Figure 57 shows the bootloader selection mechanism.

Figure 57. Bootloader V9.0 selection for STM32H72xxx/73xxx

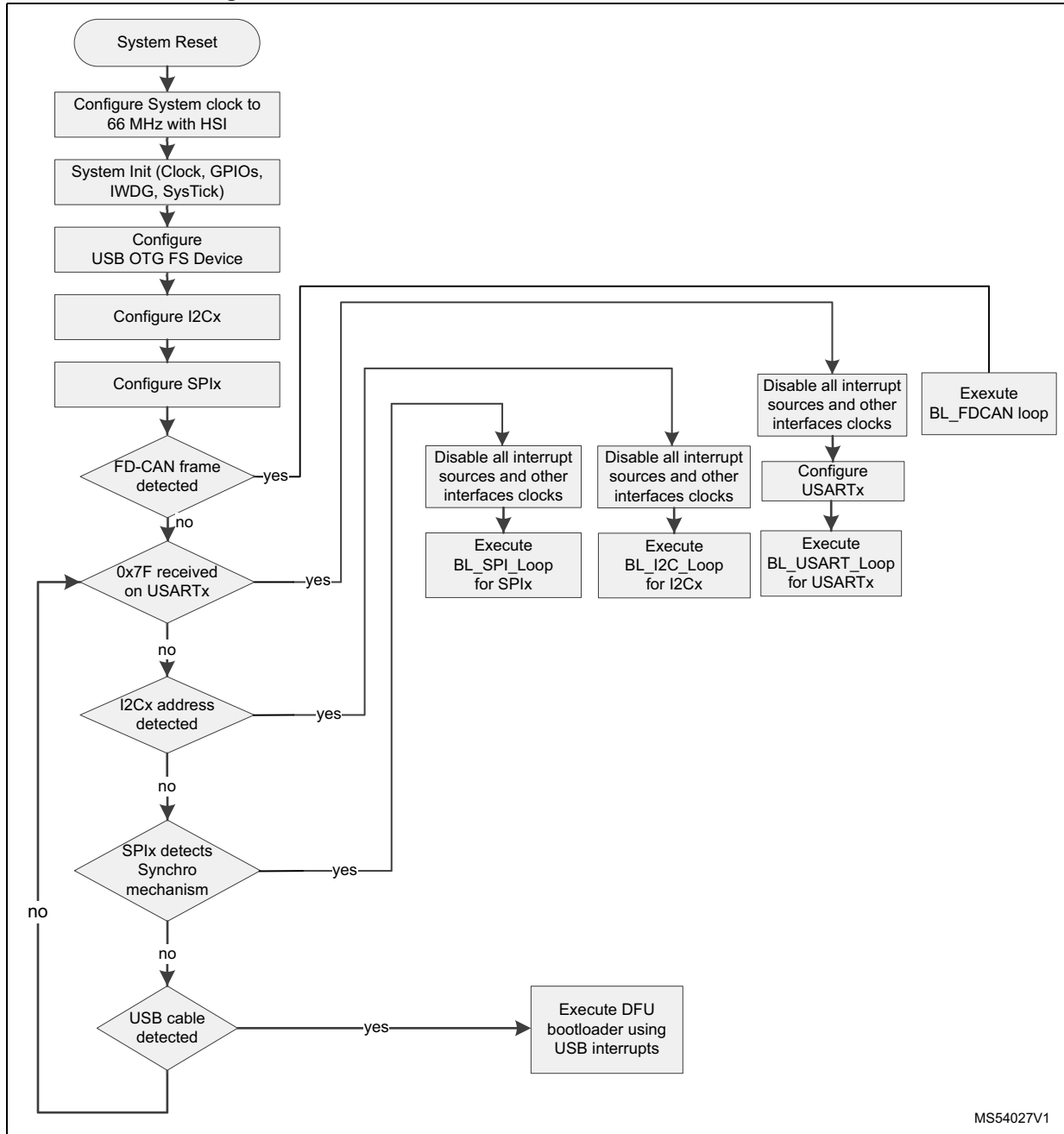

45.3 Bootloader version

[Table 100](#) lists the STM32H72xxx/73xxx devices bootloader versions.

Table 98. STM32H72xxx/73xxx bootloader version

Bootloader version number	Description	Known limitations
V9.1	Initial bootloader version	<ul style="list-style-type: none">– TCM_AXI OB cannot be modified using all BL interfaces– String returned describing the memory size when using USB is wrong
V9.2	Fix all issues of previous release	None

46 STM32H74xxx/75xxx devices bootloader

46.1 Bootloader configuration

The STM32H74xxx/75xxx bootloader is activated by applying Pattern 10 (described in [Table 2: Bootloader activation patterns](#)). [Table 99](#) shows the hardware resources used by this bootloader.

Table 99. STM32H74xxx/75xxx configuration in system memory boot mode

Bootloader	Feature/Peripheral	State	Comment
Common to all bootloaders	RCC	HSI enabled	The system clock frequency is 64 MHz using the HSI. The HSI clock source is used at startup (interface detection phase) and when USART or SPI or I2C interface is selected.
		-	The clock recovery system (CRS) is enabled for the DFU bootloader to allow USB to be clocked by HSI48 48 MHz
		-	Clock used for the FDCAN is fixed to 20 MHz and is derived from PLLQ
	RAM	-	16 Kbyte starting from address 0x20000000, and 208 Kbyte starting from address 0x24000000 are used by the bootloader firmware
	System memory	-	122 Kbyte starting from address 0x1FFF0000, contain the bootloader firmware
	IWDG	-	The independent watchdog (IWDG) prescaler is configured to its maximum value. It is periodically refreshed to prevent watchdog reset (in case the hardware IWDG option was previously enabled by the user).
	Power	-	Voltage range is set to Voltage Range 3.
USART1 bootloader (on PA9/PA10)	USART1	Enabled	Once initialized the USART1 configuration is: 8-bit, even parity and 1 Stop bit
	USART1_RX pin	Input	PA10 pin: USART1 in reception mode
	USART1_TX pin	Output	PA9 pin: USART1 in transmission mode
USART1 bootloader (on PB14/PB15)	USART1	Enabled	Once initialized the USART1 configuration is: 8-bit, even parity and 1 Stop bit
	USART1_RX pin	Input	PB15 pin: USART1 in reception mode
	USART1_TX pin	Output	PB14 pin: USART1 in transmission mode
USART2 bootloader	USART2	Enabled	Once initialized the USART2 configuration is: 8-bit, even parity and 1 Stop bit
	USART2_RX pin	Input	PA3 pin: USART2 in reception mode
	USART2_TX pin	Output	PA2 pin: USART2 in transmission mode

Table 99. STM32H74xxx/75xxx configuration in system memory boot mode (continued)

Bootloader	Feature/Peripheral	State	Comment
USART3 bootloader	USART3	Enabled	Once initialized the USART3 configuration is: 8-bit, even parity and 1 Stop bit
	USART3_RX pin	Input	PB11 pin: USART3 in reception mode
	USART3_TX pin	Output	PB10 pin: USART3 in transmission mode
I2C1 bootloader	I2C1	Enabled	The I2C1 configuration is: I2C speed: up to 400 kHz, 7-bit address, slave mode, analog filter ON. Slave 7-bit address: 0b1001110x (where x = 0 for write and x = 1 for read)
	I2C1_SCL pin	Input/Output	PB6 pin: clock line is used in open-drain mode.
	I2C1_SDA pin	Input/Output	PB9 pin: data line is used in open-drain mode.
I2C2 bootloader	I2C2	Enabled	The I2C2 configuration is: I2C speed: up to 400 kHz, 7-bit address, slave mode, analog filter ON. Slave 7-bit address: 0b1001110x (where x = 0 for write and x = 1 for read)
	I2C2_SCL pin	Input/Output	PF1 pin: clock line is used in open-drain mode.
	I2C2_SDA pin	Input/Output	PF0 pin: data line is used in open-drain mode.
I2C3 bootloader	I2C3	Enabled	The I2C3 configuration is: I2C speed: up to 400 kHz, 7-bit address, slave mode, analog filter ON. Slave 7-bit address: 0b1001110x (where x = 0 for write and x = 1 for read)
	I2C3_SCL pin	Input/Output	PA8 pin: clock line is used in open-drain mode.
	I2C3_SDA pin	Input/Output	PC9 pin: data line is used in open-drain mode.
SPI1 bootloader	SPI1	Enabled	The SPI1 configuration is: – Slave mode – Full Duplex – 8-bit MSB – Speed up to 8 MHz – Polarity: CPOL Low, CPHA Low, NSS hardware.
	SPI1_MOSI pin	Input	PA7 pin: Slave data Input line, used in push-pull, pull-down mode.
	SPI1_MISO pin	Output	PA6 pin: Slave data output line, used in push-pull, pull-down mode.
	SPI1_SCK pin	Input	PA5 pin: Slave clock line, used in push-pull, pull-down mode.
	SPI1_NSS pin	Input	PA4 pin: slave chip select pin used in push-pull, pull-down mode.

Table 99. STM32H74xxx/75xxx configuration in system memory boot mode (continued)

Bootloader	Feature/Peripheral	State	Comment
SPI2 bootloader	SPI2	Enabled	The SPI2 configuration is: – Slave mode – Full Duplex – 8-bit MSB – Speed up to 8 MHz – Polarity: CPOL Low, CPHA Low, NSS hardware.
	SPI2_MOSI pin	Input	PI3 pin: Slave data Input line, used in push-pull, pull-down mode.
	SPI2_MISO pin	Output	PI2 pin: Slave data output line, used in push-pull, pull-down mode.
	SPI2_SCK pin	Input	PI1 pin: Slave clock line, used in push-pull, pull-down mode.
	SPI2_NSS pin	Input	PI0 pin: slave chip select pin used in push-pull, pull-down mode.
SPI3 bootloader	SPI3	Enabled	The SPI3 configuration is: – Slave mode – Full Duplex – 8-bit MSB – Speed up to 8 MHz – Polarity: CPOL Low, CPHA Low, NSS hardware.
	SPI3_MOSI pin	Input	PC12 pin: Slave data Input line, used in push-pull, pull-down mode
	SPI3_MISO pin	Output	PC11 pin: Slave data output line, used in push-pull, pull-down mode.
	SPI3_SCK pin	Input	PC10 pin: Slave clock line, used in push-pull, pull-down mode.
	SPI3_NSS pin	Input	PA15 pin: slave chip select pin used in push-pull, n pull-down mode.
SPI4 bootloader	SPI4	Enabled	The SPI4 configuration is: – Slave mode – Full Duplex – 8-bit MSB – Speed up to 8 MHz – Polarity: CPOL Low, CPHA Low, NSS hardware.
	SPI4_MOSI pin	Input	PE14 pin: Slave data Input line, used in push-pull, pull-down mode.
	SPI4_MISO pin	Output	PE13 pin: Slave data output line, used in push-pull, pull-down mode.
	SPI4_SCK pin	Input	PE12 pin: Slave clock line, used in push-pull, pull-down mode.
	SPI4_NSS pin	Input	PE11 pin: slave chip select pin used in push-pull, pull-down mode.

Table 99. STM32H74xxx/75xxx configuration in system memory boot mode (continued)

Bootloader	Feature/Peripheral	State	Comment
DFU bootloader	USB	Enabled	USB FS configured in forced device mode. USB FS interrupt vector is enabled and used for USB DFU communications.
	USB_DM pin	Input/Output	PA11: USB DM line.
	USB_DP pin		PA12: USB DP line No external pull-up resistor is required
FDCAN bootloader	FDCAN1	Enabled	Once initialized the FDCAN1 configuration is: bit-rate 0.5 Mbps FrameFormat = FDCAN_FRAME_FD_BRS Mode = FDCAN_MODE_NORMAL AutoRetransmission = ENABLE TransmitPause = DISABLE ProtocolException = ENABLE
	FDCAN1_Rx pin	Input	PH14 pin: FDCAN1 in reception mode
	FDCAN1_Tx pin	Output	PH13 pin: FDCAN1 in transmission mode

Note: To connect to the bootloader USART1 using PB14/PB15 pins, user must send two synchronization bytes.

DFU mode does not support USBREGEN mode. If STM32 is powered by 1.8 V source, it is not possible to use the BL DFU unless 3.3 V is provided

46.2 Bootloader selection

Figure 58 shows the bootloader selection mechanism.

Figure 58. Bootloader V9.x selection for STM32H74xxx/75xxx

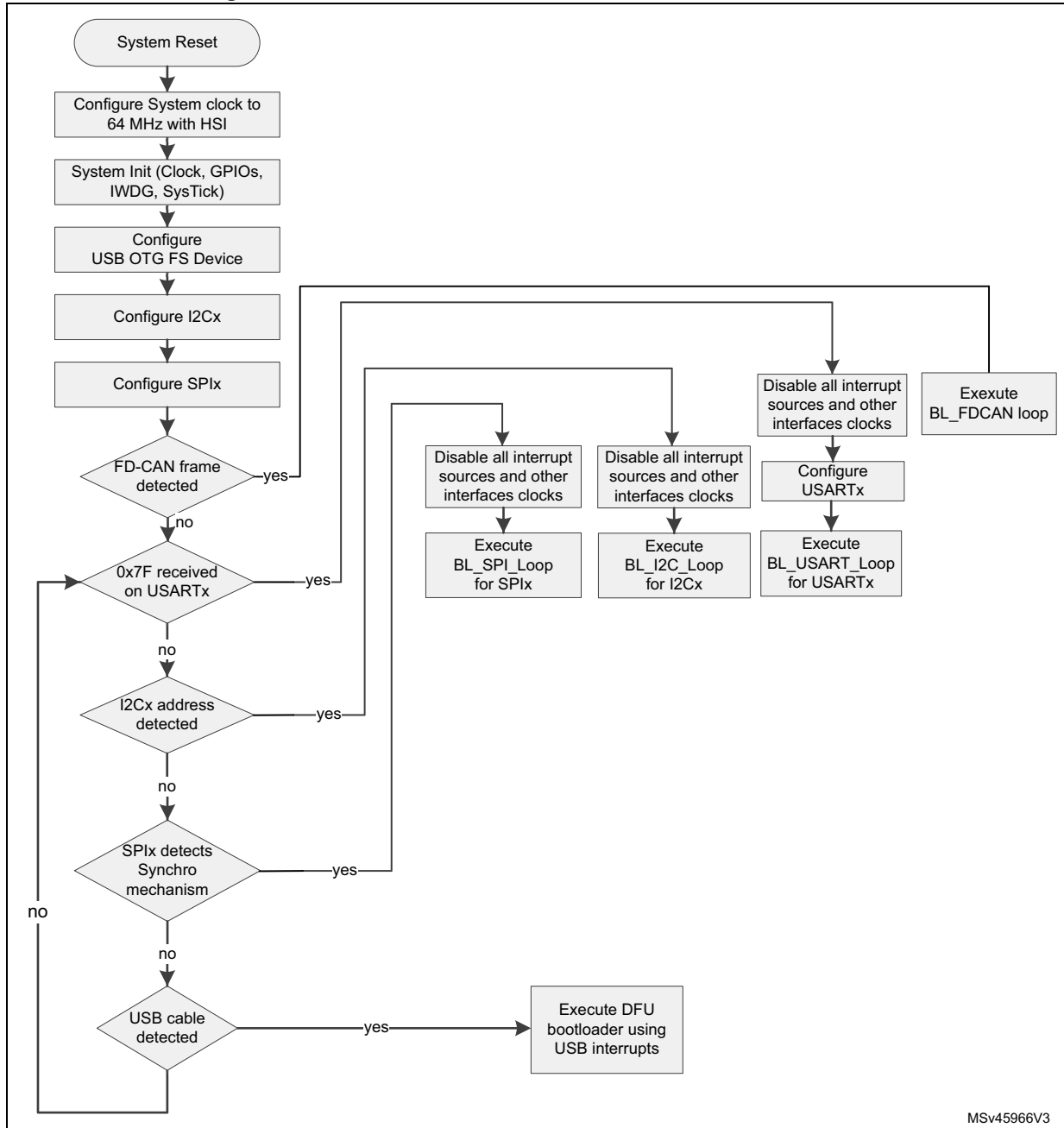

46.3 Bootloader version

Table 100 lists the STM32H74xxx/75xxx devices bootloader versions.

Table 100. STM32H74xxx/75xxx bootloader version

Bootloader version number	Description	Known limitations
V13.2 (0xD2)	Initial bootloader version	<ul style="list-style-type: none"> – “Go” Command is not working – USART2 connection is not working – SPI1 connection is not working – Mass erase is not working well on I2C (only Bank2 is erased in this command)
V13.3 (0xD3)	<ul style="list-style-type: none"> – Switch USB clock input from HSE to HSI48 with CRS – Fix known limitations on the V13.2 	<ul style="list-style-type: none"> – Bank erase is not working on USART/SPI and I2C – DFU bootloader mass-erase not working
V9.0 (0x90)	<ul style="list-style-type: none"> – Add support of FDCAN interface – Fix V13.3 limitations – V9.0 is the latest version in production and replaces V13.2 and V13.3 	<ul style="list-style-type: none"> – First ACK not received on “Go” Command when using USART or SPI – Limitation on the FDCAN write memory, write of data with length > 63 bytes is failing – If PB15 is set to GND, user will not be able to connect to BL interfaces. Only the USB is able to connect as it uses interrupt for detection. PB15 must not be pulled down if USART1 on PB14/PB15 is not used – Jump issue on some application. Application stack pointer must be lower than (RAM end @ - 16 bytes) to guarantee it is working – Additional reset needed after power off/on to enable connection to the BL interfaces

47 STM32H7A3xx/B3xx devices bootloader

47.1 Bootloader configuration

The STM32H7A3xx/7B3xx bootloader is activated by applying Pattern 10 (described in [Table 2: Bootloader activation patterns](#)). The following table shows the hardware resources used by this bootloader.

Table 101. STM32H7A3xx/7B3xx configuration in system memory boot mode

Bootloader	Feature/Peripheral	State	Comment
Common to all bootloaders	RCC	HSI enabled	The system clock frequency is 64 MHz using the HSI.
		-	The clock recovery system (CRS) is enabled for the DFU bootloader to allow USB to be clocked by HSI48 48 MHz
		-	Clock used for the FDCAN is fixed to 20 MHz and is derived from PLLQ
	RAM	-	16 Kbyte starting from address 0x24000000 are used by the bootloader firmware
	System memory	-	40 Kbytes starting from address 0x1FFFA000, contain the bootloader firmware
	IWDG	-	The independent watchdog (IWDG) prescaler is configured to its maximum value. It is periodically refreshed to prevent watchdog reset (in case the hardware IWDG option was previously enabled by the user).
USART1 bootloader	USART1	Enabled	Once initialized the USART1 configuration is: 8-bit, even parity and 1 Stop bit
	USART1_RX pin	Input	PA10 pin: USART1 in reception mode
	USART1_TX pin	Output	PA9 pin: USART1 in transmission mode
USART2 bootloader	USART2	Enabled	Once initialized the USART2 configuration is: 8-bit, even parity and 1 Stop bit
	USART2_RX pin	Input	PA3 pin: USART2 in reception mode
	USART2_TX pin	Output	PA2 pin: USART2 in transmission mode
USART3 bootloader on (PB10/PB11)	USART3	Enabled	Once initialized the USART3 configuration is: 8-bit, even parity and 1 Stop bit
	USART3_RX pin	Input	PB11 pin: USART3 in reception mode
	USART3_TX pin	Output	PB10 pin: USART3 in transmission mode
USART3 bootloader on (PD8/PD9)	USART3	Enabled	Once initialized the USART3 configuration is: 8-bit, even parity and 1 Stop bit
	USART3_RX pin	Input	PD9 pin: USART3 in reception mode
	USART3_TX pin	Output	PD8 pin: USART3 in transmission mode

Table 101. STM32H7A3xx/7B3xx configuration in system memory boot mode (continued)

Bootloader	Feature/Peripheral	State	Comment
I2C1 bootloader	I2C1	Enabled	The I2C1 configuration is: I2C speed: up to 400 kHz, 7-bit address, slave mode, analog filter ON. Slave 7-bit address: 0b10101111x (where x = 0 for write and x = 1 for read)
	I2C1_SCL pin	Input/Output	PB6 pin: clock line is used in open-drain mode.
	I2C1_SDA pin	Input/Output	PB9 pin: data line is used in open-drain mode.
I2C2 bootloader	I2C2	Enabled	The I2C2 configuration is: I2C speed: up to 400 kHz, 7-bit address, slave mode, analog filter ON. Slave 7-bit address: 0b10101111x (where x = 0 for write and x = 1 for read)
	I2C2_SCL pin	Input/Output	PF1 pin: clock line is used in open-drain mode.
	I2C2_SDA pin	Input/Output	PF0 pin: data line is used in open-drain mode.
I2C3 bootloader	I2C3	Enabled	The I2C3 configuration is: I2C speed: up to 400 kHz, 7-bit address, slave mode, analog filter ON. Slave 7-bit address: 0b10101111x (where x = 0 for write and x = 1 for read)
	I2C3_SCL pin	Input/Output	PA8 pin: clock line is used in open-drain mode.
	I2C3_SDA pin	Input/Output	PC9 pin: data line is used in open-drain mode.
SPI1 bootloader	SPI1	Enabled	The SPI1 configuration is: – Slave mode – Full Duplex – 8-bit MSB – Speed up to 8 MHz – Polarity: CPOL Low, CPHA Low, NSS hardware.
	SPI1_MOSI pin	Input	PA7 pin: Slave data Input line, used in push-pull, no pull-up no pull-down mode.
	SPI1_MISO pin	Output	PA6 pin: Slave data output line, used in push-pull, no pull-up no pull-down mode.
	SPI1_SCK pin	Input	PA5 pin: Slave clock line, used in push-pull no pull-up, no pull-up no pull-down mode.
	SPI1_NSS pin	Input	PA4 pin: slave chip select pin used in push-pull, pull-down mode.

Table 101. STM32H7A3xx/7B3xx configuration in system memory boot mode (continued)

Bootloader	Feature/Peripheral	State	Comment
SPI2 bootloader	SPI2	Enabled	The SPI2 configuration is: – Slave mode – Full Duplex – 8-bit MSB – Speed up to 8 MHz – Polarity: CPOL Low, CPHA Low, NSS hardware.
	SPI2_MOSI pin	Input	PB15 pin: Slave data Input line, used in push-pull, pull-down mode.
	SPI2_MISO pin	Output	PB14 pin: Slave data output line, used in push-pull, pull-down mode.
	SPI2_SCK pin	Input	PB13 pin: Slave clock line, used in push-pull, pull-down mode.
	SPI2_NSS pin	Input	PB12 pin: slave chip select pin used in push-pull, pull-down mode.
SPI3 bootloader	SPI3	Enabled	The SPI3 configuration is: – Slave mode – Full Duplex – 8-bit MSB – Speed up to 8 MHz – Polarity: CPOL Low, CPHA Low, NSS hardware.
	SPI3_MOSI pin	Input	PC12 pin: Slave data Input line, used in push-pull, pull-down mode
	SPI3_MISO pin	Output	PC11 pin: Slave data output line, used in push-pull, pull-down mode.
	SPI3_SCK pin	Input	PC10 pin: Slave clock line, used in push-pull, pull-down mode.
	SPI3_NSS pin	Input	PA15 pin: slave chip select pin used in push-pull, pull-down mode.
DFU bootloader	USB	Enabled	USB FS configured in forced device mode. USB FS interrupt vector is enabled and used for USB DFU communications.
	USB_DM pin	Input/Output	PA11: USB DM line.
	USB_DP pin		PA12: USB DP line No external pull-up resistor is required

Table 101. STM32H7A3xx/7B3xx configuration in system memory boot mode (continued)

Bootloader	Feature/Peripheral	State	Comment
FDCAN bootloader on (PH13/PH14)	FDCAN1	Enabled	Once initialized the FDCAN1 configuration is: bit-rate 0.5 Mbps FrameFormat = FDCAN_FRAME_FD_BRS Mode = FDCAN_MODE_NORMAL AutoRetransmission = ENABLE TransmitPause = DISABLE ProtocolException = ENABLE
	FDCAN1_Rx pin	Input	PH14 pin: FDCAN1 in reception mode
	FDCAN1_Tx pin	Output	PH13 pin: FDCAN1 in transmission mode
FDCAN bootloader on (PD1/PD0)	FDCAN1	Enabled	Once initialized the FDCAN1 configuration is: bit-rate 0.5 Mbps FrameFormat = FDCAN_FRAME_FD_BRS Mode = FDCAN_MODE_NORMAL AutoRetransmission = ENABLE TransmitPause = DISABLE ProtocolException = ENABLE
	FDCAN1_Rx pin	Input	PD0 pin: FDCAN1 in reception mode
	FDCAN1_Tx pin	Output	PD1 pin: FDCAN1 in transmission mode

47.2 Bootloader selection

Figure 58 shows the bootloader selection mechanism.

Figure 59. Bootloader V9.x selection for STM32H7A3xx/7B3xx

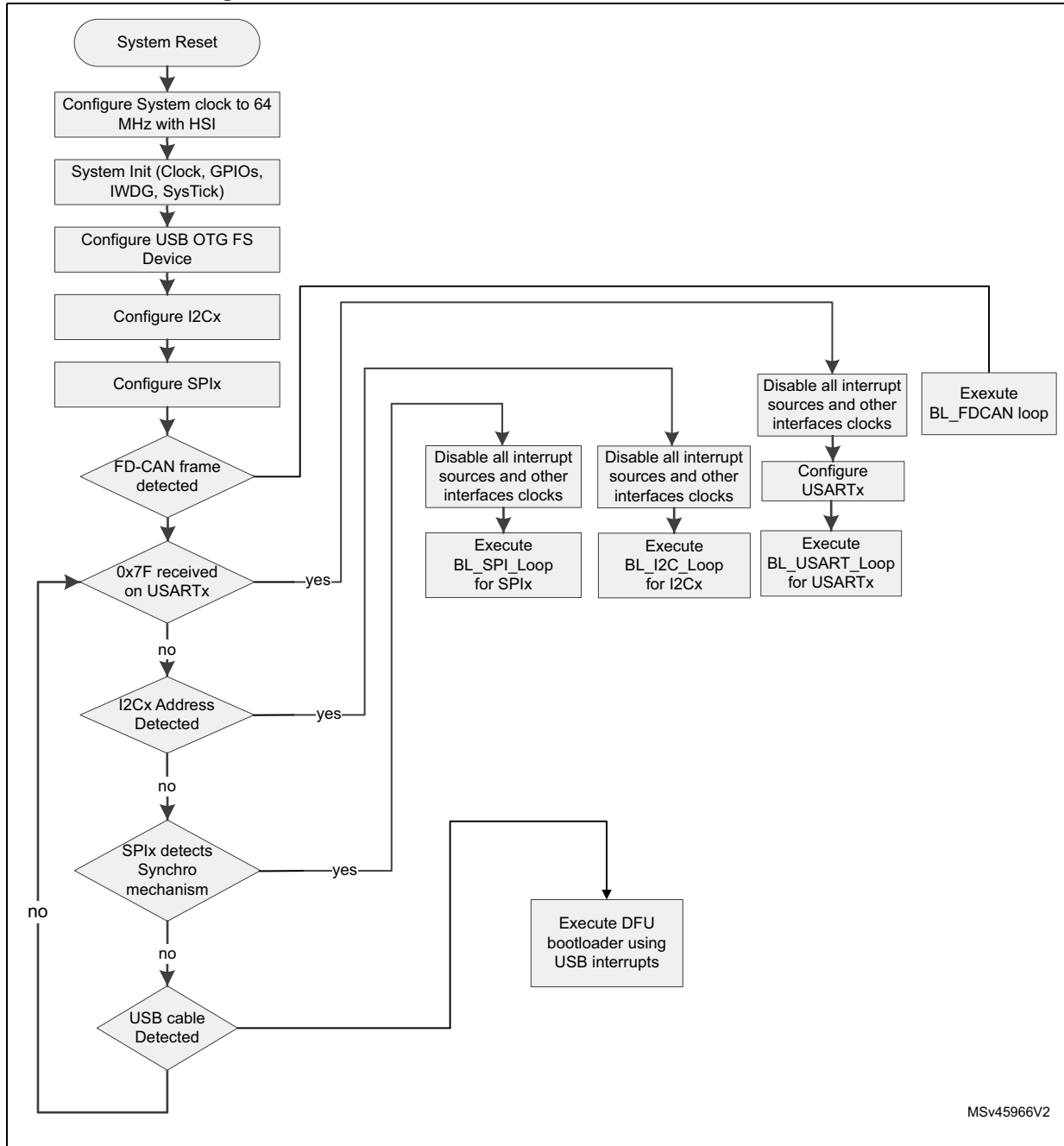

47.3 Bootloader version

[Table 100](#) lists the STM32H7A3xx/7B3xx devices bootloader versions.

Table 102. STM32H7A3xx/7B3xx bootloader version

Bootloader version number	Description	Known limitations
V9.0	Initial bootloader version	<ul style="list-style-type: none">– String returned describing the Flash memory size when using USB is wrong (expected value 256 x 8 KB, but returns 256 x 2 KB)– OTP memory is not supported by the bootloader
V9.1	Fixes all issues of previous release.	None

48 STM32L01xxx/02xxx devices bootloader

48.1 Bootloader configuration

The STM32L01xxx/02xxx bootloader is activated by applying Pattern 6 (described in [Table 2: Bootloader activation patterns](#)). [Table 103](#) shows the hardware resources used by this bootloader.

Table 103. STM32L01xxx/02xxx configuration in system memory boot mode

Bootloader	Feature/Peripheral	State	Comment
Common to all bootloaders	RCC	HSI enabled	The system clock frequency is 32 MHz with HSI 16 MHz as clock source.
	RAM	-	2 Kbyte starting from address 0x20000000 are used by the bootloader firmware
	System memory	-	4 Kbyte starting from address 0x1FF00000, contain the bootloader firmware
	IWDG	-	The independent watchdog (IWDG) prescaler is configured to its maximum value. It is periodically refreshed to prevent watchdog reset (in case the hardware IWDG option was previously enabled by the user).
USART1 bootloader (on PA9/PA10)	USART1	Enabled	Once initialized the USART1 configuration is: 8-bit, even parity and 1 Stop bit
	USART1_RX pin	Input	PA10 pin: USART1 in reception mode
	USART1_TX pin	Output	PA9 pin: USART1 in transmission mode
USART2 bootloader (on PA2/PA3)	USART2	Enabled	Once initialized the USART2 configuration is: 8-bit, even parity and 1 Stop bit
	USART2_RX pin	Input	PA3 pin: USART2 in reception mode
	USART2_TX pin	Output	PA2 pin: USART2 in transmission mode
USART2 bootloader	SysTick timer	Enabled	Used to automatically detect the serial baud rate from the host for USARTx bootloaders.
SPI1 bootloader (for all device packages except TSSOP14)	SPI1	Enabled	The SPI1 configuration is: Slave mode, Full Duplex, 8-bit MSB, Speed up to 8 MHz, Polarity: CPOL Low, CPHA Low, NSS hardware.
	SPI1_MOSI pin	Input	PA7 pin: Slave data Input line, used in push-pull, pull-down mode
	SPI1_MISO pin	Output	PA6 pin: Slave data output line, used in push-pull, pull-down mode
	SPI1_SCK pin	Input	PA5 pin: Slave clock line, used in push-pull, pull-down mode
	SPI1_NSS pin	Input	PA4 pin: slave chip select pin used in push-pull, pull-down mode. Note: This IO can be tied to GND if the SPI Master does not use it.

Table 103. STM32L01xxx/02xxx configuration in system memory boot mode (continued)

Bootloader	Feature/Peripheral	State	Comment
SPI1 bootloader (only for devices on TSSOP14 package)	SPI1	Enabled	The SPI1 configuration is: Slave mode, Full Duplex, 8-bit MSB, Speed up to 8 MHz, Polarity: CPOL Low, CPHA Low, NSS hardware.
	SPI1_MOSI pin	Input	PA7 pin: Slave data Input line, used in push-pull, pull-down mode
	SPI1_MISO pin	Output	PA14 pin: Slave data output line, used in push-pull, pull-down mode. Note: This IO is also used as SWCLK for debug interface, as a consequence debugger cannot connect to the device in "on-the-fly" mode when the bootloader is running.
	SPI1_SCK pin	Input	PA13 pin: Slave clock line, used in push-pull, pull-down mode
	SPI1_NSS pin	Input	PA4 pin: slave chip select pin used in push-pull, pull-down mode. Note: NSS pin synchronization is required on bootloader with SPI1 interface for devices on TSSOP14 package.

The system clock is derived from the embedded internal high-speed RC for all bootloader interfaces. No external quartz is required for bootloader operations.

Note: Due to empty check mechanism present on this product, it is not possible to jump from user code to system bootloader. Such jump results in a jump back to user Flash memory space. But if the first 4 bytes of user lash memory (at 0x0800 0000) are empty at the moment of the jump (i.e. erase first sector before jump or execute code from SRAM while Flash is empty), then system bootloader is executed when jumped to.

48.2 Bootloader selection

The [Table 60](#) shows the bootloader selection mechanism.

Figure 60. Bootloader selection for STM32L01xxx/02xxx

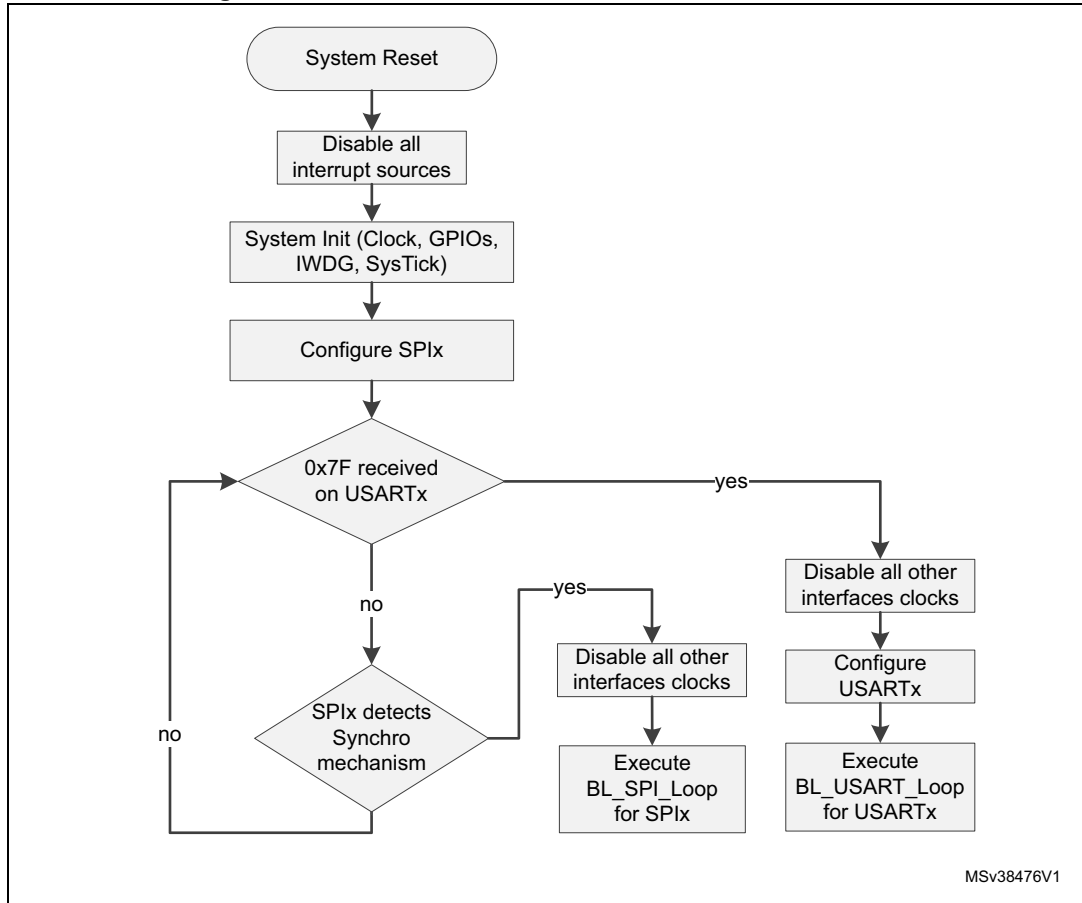

48.3 Bootloader version

The following table lists the STM32L01xxx/02xxx devices bootloader versions.

Table 104. STM32L01xxx/02xxx bootloader versions

Bootloader version number	Description	Known limitations
V12.2	Initial bootloader version	Bootloader not functional with SPI1 interface for devices on TSSOP14 package.
V12.3	This bootloader is an updated version of bootloader V12.2. This new version add support of SPI interface for devices on TSSOP14 package.	For the SPI1 interface for devices in TSSOP14, a falling edge on NSS pin is required before starting communication, to properly synchronize the SPI interface. If the NSS pin is grounded (all time from device reset) the SPI communication is not synchronized and bootloader does not work properly with the SPI interface.

49 STM32L031xx/041xx devices bootloader

49.1 Bootloader configuration

The STM32L031xx/041xx bootloader is activated by applying Pattern 2 (described in [Table 2: Bootloader activation patterns](#)). The following table shows the hardware resources used by this bootloader.

Table 105. STM32L031xx/041xx configuration in system memory boot mode

Bootloader	Feature/Peripheral	State	Comment
Common to all bootloaders	RCC	HSI enabled	The system clock frequency is 32 MHz with HSI 16 MHz as clock source.
	RAM	-	4 Kbyte starting from address 0x20000000 are used by the bootloader firmware
	System memory	-	4 Kbyte starting from address 0x1FF00000, contain the bootloader firmware
	IWDG	-	The independent watchdog (IWDG) prescaler is configured to its maximum value. It is periodically refreshed to prevent watchdog reset (in case the hardware IWDG option was previously enabled by the user).
USART2 bootloader (on PA9/PA10)	USART2	Enabled	Once initialized the USART2 configuration is: 8-bit, even parity and 1 Stop bit
	USART2_RX pin	Input	PA10 pin: USART2 in reception mode
	USART2_TX pin	Output	PA9 pin: USART2 in transmission mode
USART2 bootloader (on PA2/PA3)	USART2	Enabled	Once initialized the USART2 configuration is: 8-bit, even parity and 1 Stop bit
	USART2_RX pin	Input	PA3 pin: USART2 in reception mode
	USART2_TX pin	Output	PA2 pin: USART2 in transmission mode
USART2 bootloader	SysTick timer	Enabled	Used to automatically detect the serial baud rate from the host for USARTx bootloaders.
SPI1 bootloader	SPI1	Enabled	The SPI1 configuration is: Slave mode, Full Duplex, 8-bit MSB, Speed up to 8 MHz, Polarity: CPOL Low, CPHA Low, NSS hardware.
	SPI1_MOSI pin	Input	PA7 pin: Slave data Input line, used in push-pull, pull-down mode
	SPI1_MISO pin	Output	PA6 pin: Slave data output line, used in push-pull, pull-down mode
	SPI1_SCK pin	Input	PA5 pin: Slave clock line, used in push-pull, pull-down mode
	SPI1_NSS pin	Input	PA4 pin: slave chip select pin used in push-pull, pull-down mode. Note: This IO can be tied to GND if the SPI Master does not use it.

The system clock is derived from the embedded internal high-speed RC for all bootloader interfaces. No external quartz is required for bootloader operations.

The bootloader Read/Write commands do not support SRAM space for this product.

49.2 Bootloader selection

Figure 61 shows the bootloader selection mechanism.

Figure 61. Bootloader selection for STM32L031xx/041xx

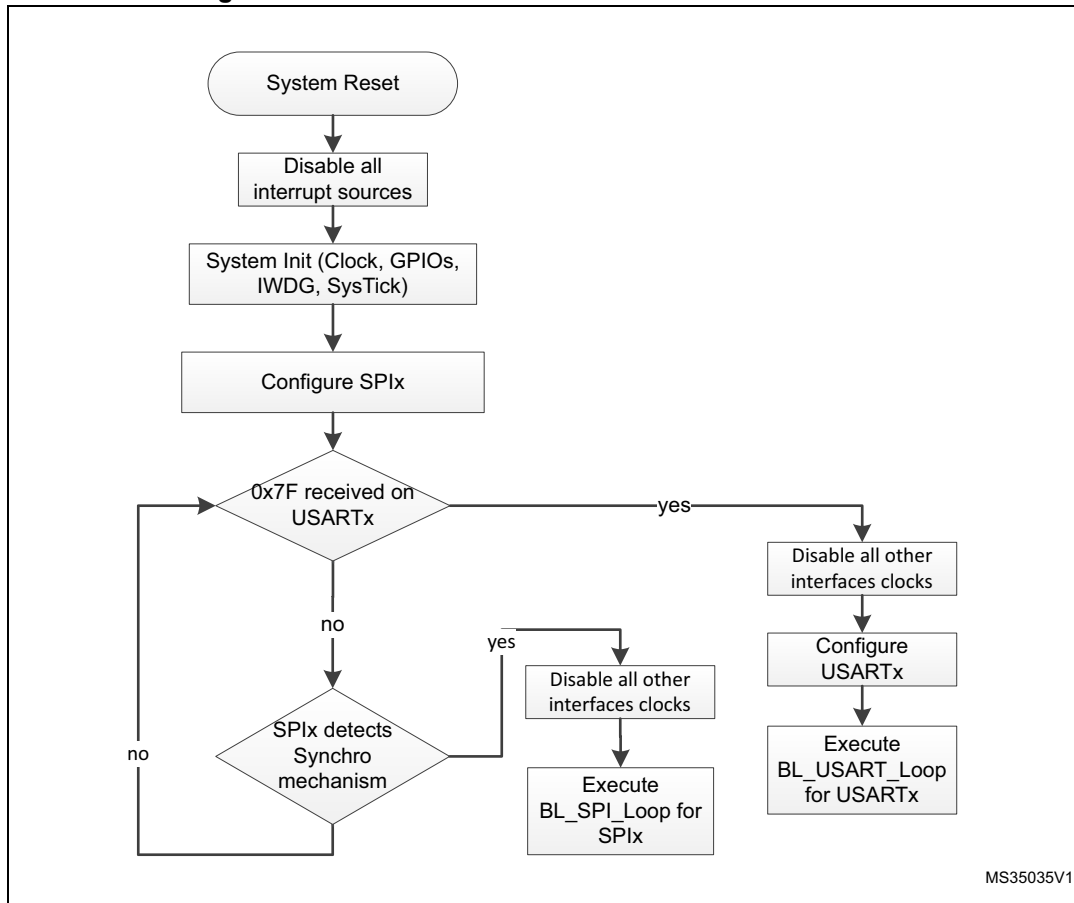

MS35035V1

49.3 Bootloader version

Table 106 lists the STM32L031xx/041xx devices bootloader versions.

Table 106. STM32L031xx/041xx bootloader versions

Bootloader version number	Description	Known limitations
V12.0	Initial bootloader version	None

50 STM32L05xxx/06xxx devices bootloader

50.1 Bootloader configuration

The STM32L05xxx/06xxx bootloader is activated by applying Pattern 1 (described in [Table 2: Bootloader activation patterns](#)). The following table shows the hardware resources used by this bootloader.

Table 107. STM32L05xxx/06xxx configuration in system memory boot mode

Bootloader	Feature/Peripheral	State	Comment
Common to all bootloaders	RCC	HSI enabled	The system clock frequency is 32 MHz with HSI 16 MHz as clock source.
	Power	-	Voltage range is set to Voltage Range 1.
	RAM	-	4 Kbyte starting from address 0x20000000 are used by the bootloader firmware
	System memory	-	4 Kbyte starting from address 0x1FF00000, contain the bootloader firmware
	IWDG	-	The independent watchdog (IWDG) prescaler is configured to its maximum value. It is periodically refreshed to prevent watchdog reset (in case the hardware IWDG option was previously enabled by the user).
USART1 bootloader	USART1	Enabled	Once initialized the USART1 configuration is: 8-bit, even parity and 1 Stop bit
	USART1_RX pin	Input	PA10 pin: USART1 in reception mode
	USART1_TX pin	Output	PA9 pin: USART1 in transmission mode
USART2 bootloader	USART2	Enabled	Once initialized the USART2 configuration is: 8-bit, even parity and 1 Stop bit
	USART2_RX pin	Input	PA3 pin: USART2 in reception mode
	USART2_TX pin	Output	PA2 pin: USART2 in transmission mode
USARTx bootloaders	SysTick timer	Enabled	Used to automatically detect the serial baud rate from the host for USARTx bootloaders.

Table 107. STM32L05xxx/06xxx configuration in system memory boot mode (continued)

Bootloader	Feature/Peripheral	State	Comment
SPI1 bootloader	SPI1	Enabled	The SPI1 configuration is: Slave mode, Full Duplex, 8-bit MSB, Speed up to 8 MHz, Polarity: CPOL Low, CPHA Low, NSS hardware.
	SPI1_MOSI pin	Input	PA7 pin: Slave data Input line, used in push-pull, pull-down mode
	SPI1_MISO pin	Output	PA6 pin: Slave data output line, used in push-pull, pull-down mode
	SPI1_SCK pin	Input	PA5 pin: Slave clock line, used in push-pull, pull-down mode
	SPI1_NSS pin	Input	PA4 pin: slave chip select pin used in push-pull, pull-down mode.
SPI2 bootloader	SPI2	Enabled	The SPI2 configuration is: Slave mode, Full Duplex, 8-bit MSB, Speed up to 8 MHz, Polarity: CPOL Low, CPHA Low, NSS hardware.
	SPI2_MOSI pin	Input	PB15 pin: Slave data Input line, used in push-pull, pull-down mode
	SPI2_MISO pin	Output	PB14 pin: Slave data output line, used in push-pull, pull-down mode
	SPI2_SCK pin	Input	PB13 pin: Slave clock line, used in push-pull, pull-down mode
	SPI2_NSS pin	Input	PB12 pin: slave chip select pin used in push-pull, pull-down mode.

The system clock is derived from the embedded internal high-speed RC for all bootloader interfaces. No external quartz is required for bootloader operations.

50.2 Bootloader selection

The figure below shows the bootloader selection mechanism.

Figure 62. Bootloader selection for STM32L05xxx/06xxx

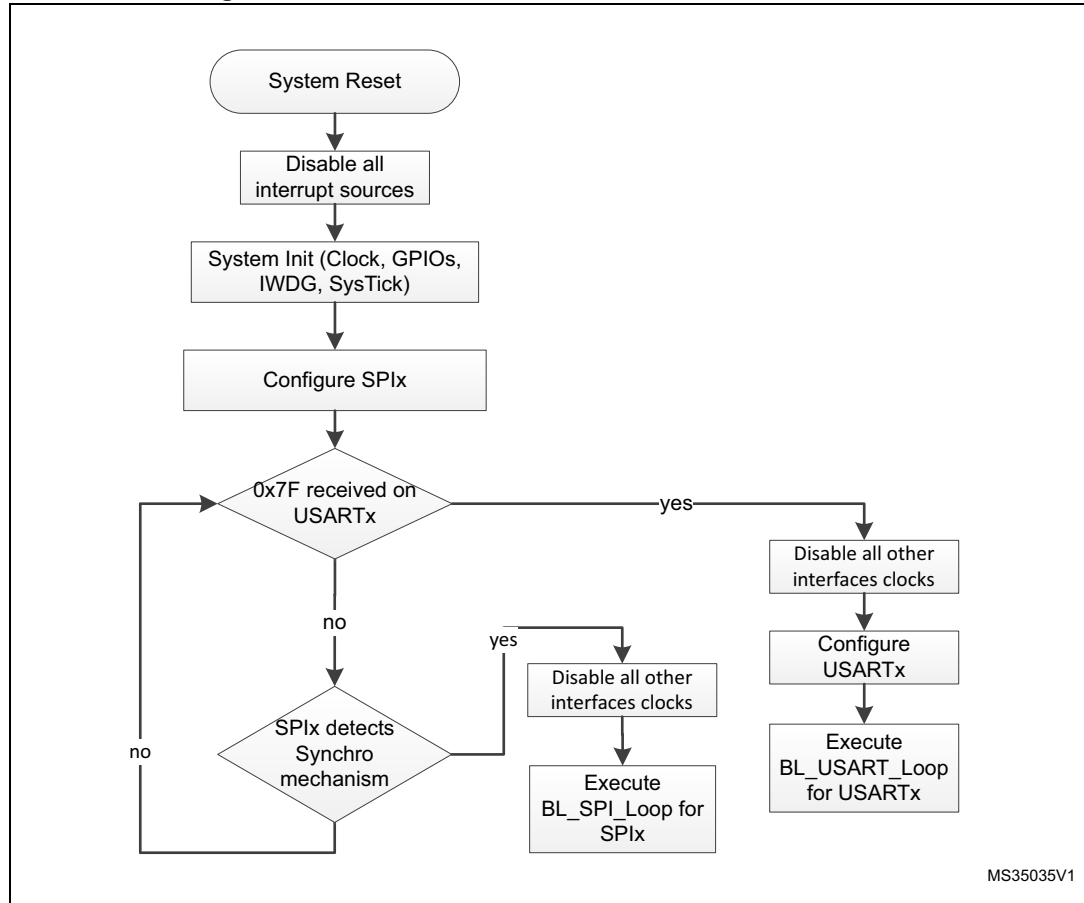

50.3 Bootloader version

The following table lists the STM32L05xxx/06xxx devices bootloader versions:

Table 108. STM32L05xxx/06xxx bootloader versions

Bootloader version number	Description	Known limitations
V12.0	Initial bootloader version	None

51 STM32L07xxx/08xxx devices bootloader

Two bootloader versions are available on STM32L07xxx/08xxx devices:

- V4.x supporting USART1, USART2 and DFU (USB FS Device).
This version is embedded in STM32L072xx/73xx and STM32L082xx/83xx devices.
- V11.x supporting USART1, USART2, I2C1, I2C2, SPI1 and SPI2.
This version is embedded in other STM32L071xx/081xx devices.

51.1 Bootloader V4.x

51.1.1 Bootloader configuration

The STM32L07xxx/08xxx bootloader is activated by applying Pattern 2 or Pattern 7 when dual bank boot feature is available (described in [Table 2: Bootloader activation patterns](#)). [Table 109](#) shows the hardware resources used by this bootloader.

Table 109. STM32L07xxx/08xxx configuration in system memory boot mode

Bootloader	Feature/Peripheral	State	Comment
Common to all bootloaders	RCC	HSI enabled	The system clock frequency is 32 MHz with HSI 16 MHz as clock source.
	RAM	-	4 Kbyte starting from address 0x20000000 are used by the bootloader firmware.
	System memory	-	8 Kbyte starting from address 0x1FF00000, contain the bootloader firmware.
	IWDG	-	The independent watchdog (IWDG) prescaler is configured to its maximum value. It is periodically refreshed to prevent watchdog reset (in case the hardware IWDG option was previously enabled by the user).
USART1 bootloader	USART1	Enabled	Once initialized the USART1 configuration is: 8-bit, even parity and 1 Stop bit
	USART1_RX pin	Input	PA10 pin: USART2 in reception mode
	USART1_TX pin	Output	PA9 pin: USART2 in transmission mode
USART2 bootloader	USART2	Enabled	Once initialized the USART2 configuration is: 8-bit, even parity and 1 Stop bit
	USART2_RX pin	Input	PA3 pin: USART2 in reception mode
	USART2_TX pin	Output	PA2 pin: USART2 in transmission mode
USARTx bootloaders	SysTick timer	Enabled	Used to automatically detect the serial baud rate from the host for USARTx bootloaders.

Table 109. STM32L07xxx/08xxx configuration in system memory boot mode (continued)

Bootloader	Feature/Peripheral	State	Comment
DFU bootloader	USB	Enabled	USB FS configured in forced device mode. USB FS interrupt vector is enabled and used for USB DFU communications.
	USB_DM pin	Input/Output	PA11 pin: USB FS DM line
	USB_DP pin		PA12 pin: USB FS DP line. No external pull-up resistor is required.

The system clock is derived from the embedded internal high-speed RC for all bootloader interfaces. No external quartz is required for bootloader operations.

51.1.2 Bootloader selection

Figure 63 and Figure 64 show the bootloader selection mechanism.

Figure 63. Dual bank boot implementation for STM32L07xxx/08xxx bootloader V4.x

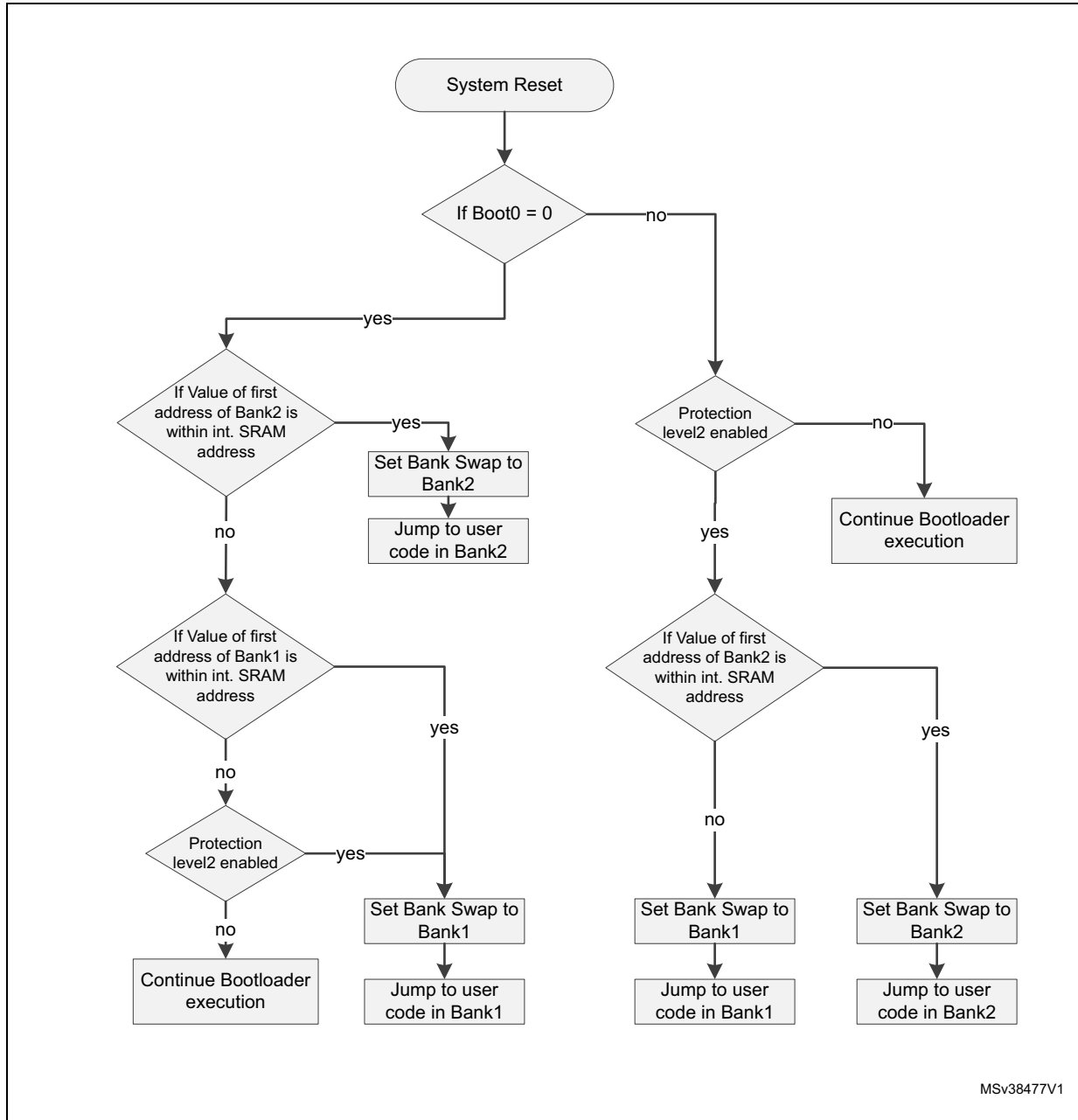
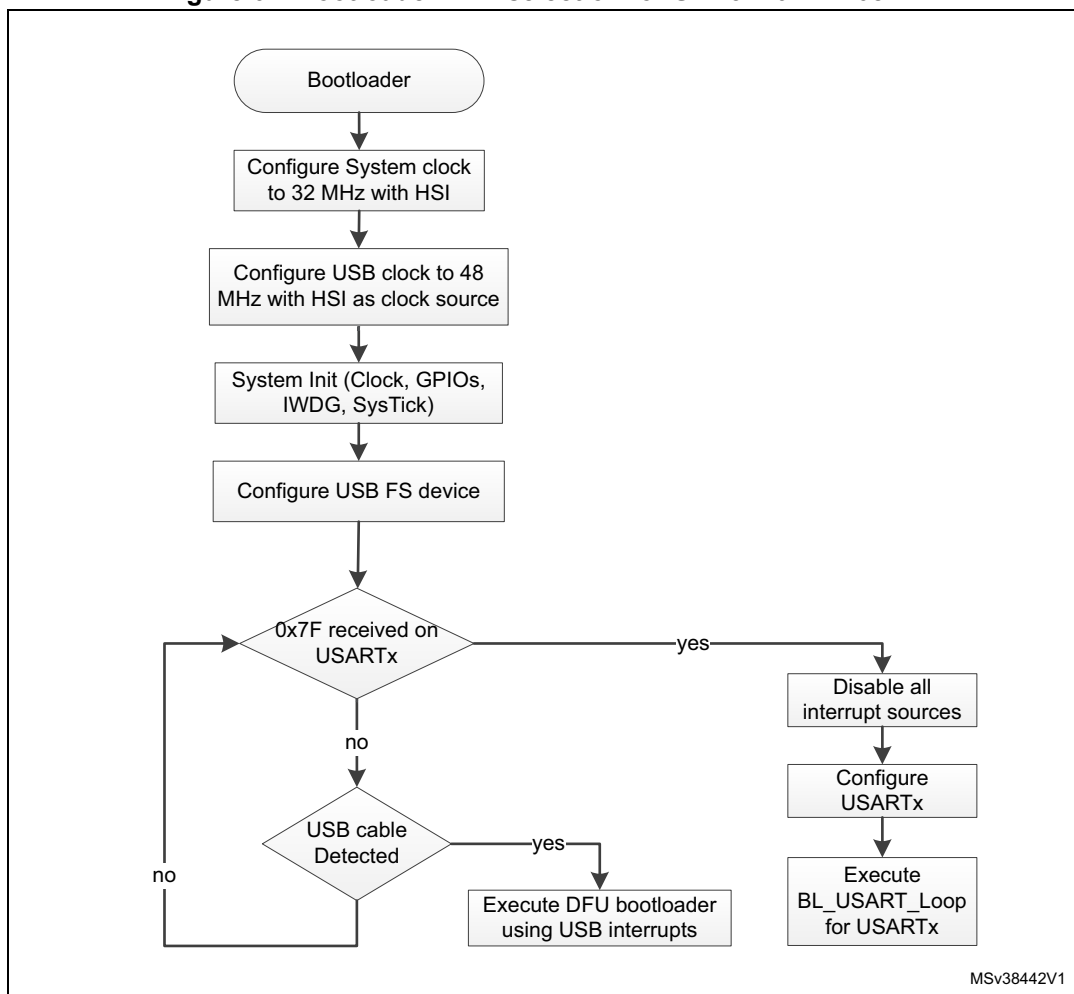

Figure 64. Bootloader V4.x selection for STM32L07xxx/08xxx



51.1.3 Bootloader version

Table 110 lists the STM32L07xxx/08xxx devices bootloader versions.

Table 110. STM32L07xxx/08xxx bootloader versions

Bootloader version number	Description	Known limitations
V4.0	Initial bootloader version	PA4, PA5, PA6 and PA7 IOs are configured in pull down mode despite not used by bootloader
V4.1	This bootloader is an updated version of bootloader V4.0. This new version implements the Dual Bank Boot feature.	PA4, PA5, PA6 and PA7 IOs are configured in pull down mode despite not used by bootloader

51.2 Bootloader V11.x

51.2.1 Bootloader configuration

The STM32L07xxx/08xxx bootloader is activated by applying Pattern 2 or Pattern 7 when dual bank boot feature is available (see in [Table 2: Bootloader activation patterns](#)). [Table 111](#) shows the hardware resources used by this bootloader.

Table 111. STM32L07xxx/08xxx configuration in system memory boot mode

Bootloader	Feature/Peripheral	State	Comment
Common to all bootloaders	RCC	HSI enabled	The system clock frequency is 32 MHz with HSI 16 MHz as clock source.
	RAM	-	5 Kbyte starting from address 0x20000000 are used by the bootloader firmware
	System memory	-	8 Kbyte starting from address 0x1FF00000, contain the bootloader firmware
	IWDG	-	The independent watchdog (IWDG) prescaler is configured to its maximum value. It is periodically refreshed to prevent watchdog reset (in case the hardware IWDG option was previously enabled by the user).
USART1 bootloader	USART1	Enabled	Once initialized the USART1 configuration is: 8-bit, even parity and 1 Stop bit
	USART1_RX pin	Input	PA10 pin: USART2 in reception mode
	USART1_TX pin	Output	PA9 pin: USART2 in transmission mode
USART2 bootloader	USART2	Enabled	Once initialized the USART2 configuration is: 8-bit, even parity and 1 Stop bit
	USART2_RX pin	Input	PA3 pin: USART2 in reception mode
	USART2_TX pin	Output	PA2 pin: USART2 in transmission mode
USARTx bootloaders	SysTick timer	Enabled	Used to automatically detect the serial baud rate from the host for USARTx bootloaders.
I2C1 bootloader	I2C1	Enabled	The I2C1 configuration is: I2C speed: up to 400 kHz, 7-bit address, slave mode, analog filter ON. Slave 7-bit address: 0b1000010x (where x = 0 for write and x = 1 for read)
	I2C1_SCL pin	Input/Output	PB6 pin: I2C1 clock line is used in open-drain mode.
	I2C1_SDA pin	Input/Output	PB7 pin: I2C1 data line is used in open-drain mode.

Table 111. STM32L07xxx/08xxx configuration in system memory boot mode (continued)

Bootloader	Feature/Peripheral	State	Comment
I2C2 bootloader	I2C2	Enabled	The I2C2 configuration is: I2C speed: up to 400 kHz, 7-bit address, slave mode, analog filter ON. Slave 7-bit address: 0b1000010x (where x = 0 for write and x = 1 for read)
	I2C2_SCL pin	Input/Output	PB10 pin: I2C2 clock line is used in open-drain mode.
	I2C2_SDA pin	Input/Output	PB11 pin: I2C2 data line is used in open-drain mode.
SPI1 bootloader	SPI1	Enabled	The SPI1 configuration is: Slave mode, Full Duplex, 8-bit MSB, Speed up to 8 MHz, Polarity: CPOL Low, CPHA Low, NSS hardware.
	SPI1_MOSI pin	Input	PA7 pin: Slave data Input line, used in push-pull, pull-down mode
	SPI1_MISO pin	Output	PA6 pin: Slave data output line, used in push-pull, pull-down mode
	SPI1_SCK pin	Input	PA5 pin: Slave clock line, used in push-pull, pull-down mode
	SPI1_NSS pin	Input	PA4 pin: slave chip select pin used in push-pull, pull-down mode. Note: This IO can be tied to GND if the SPI Master does not use it.
SPI2 bootloader	SPI2	Enabled	The SPI2 configuration is: Slave mode, Full Duplex, 8-bit MSB, Speed up to 8 MHz, Polarity: CPOL Low, CPHA Low, NSS hardware.
	SPI2_MOSI pin	Input	PB15 pin: Slave data Input line, used in push-pull, pull-down mode
	SPI2_MISO pin	Output	PB14 pin: Slave data output line, used in push-pull, pull-down mode
	SPI2_SCK pin	Input	PB13 pin: Slave clock line, used in push-pull, pull-down mode
		SPI2_NSS pin	Input

The system clock is derived from the embedded internal high-speed RC for all bootloader interfaces. No external quartz is required for bootloader operations.

51.2.2 Bootloader selection

Figure 65 and Figure 66 show the bootloader selection mechanism.

Figure 65. Dual bank boot implementation for STM32L07xxx/08xxx bootloader V11.x

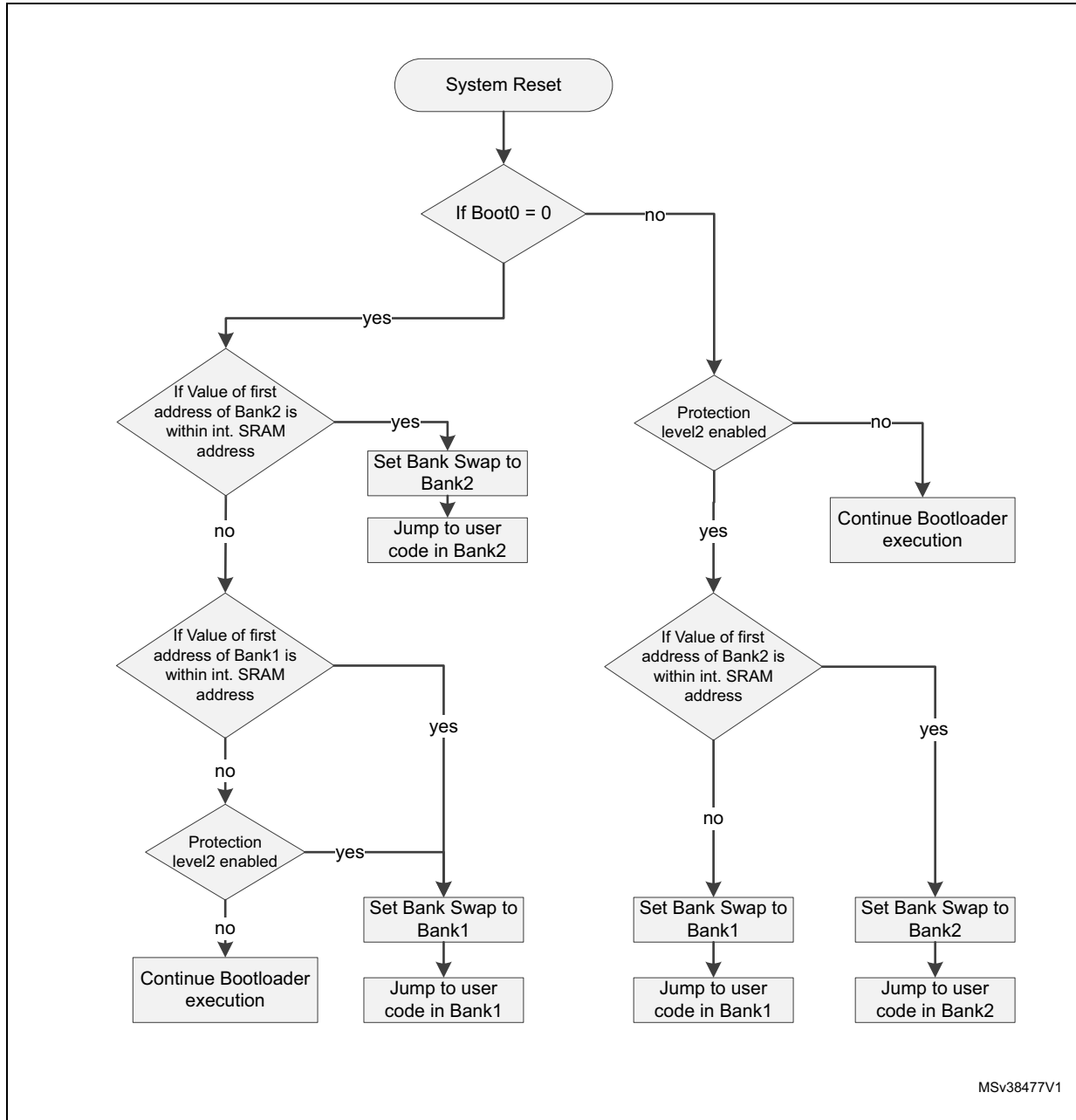
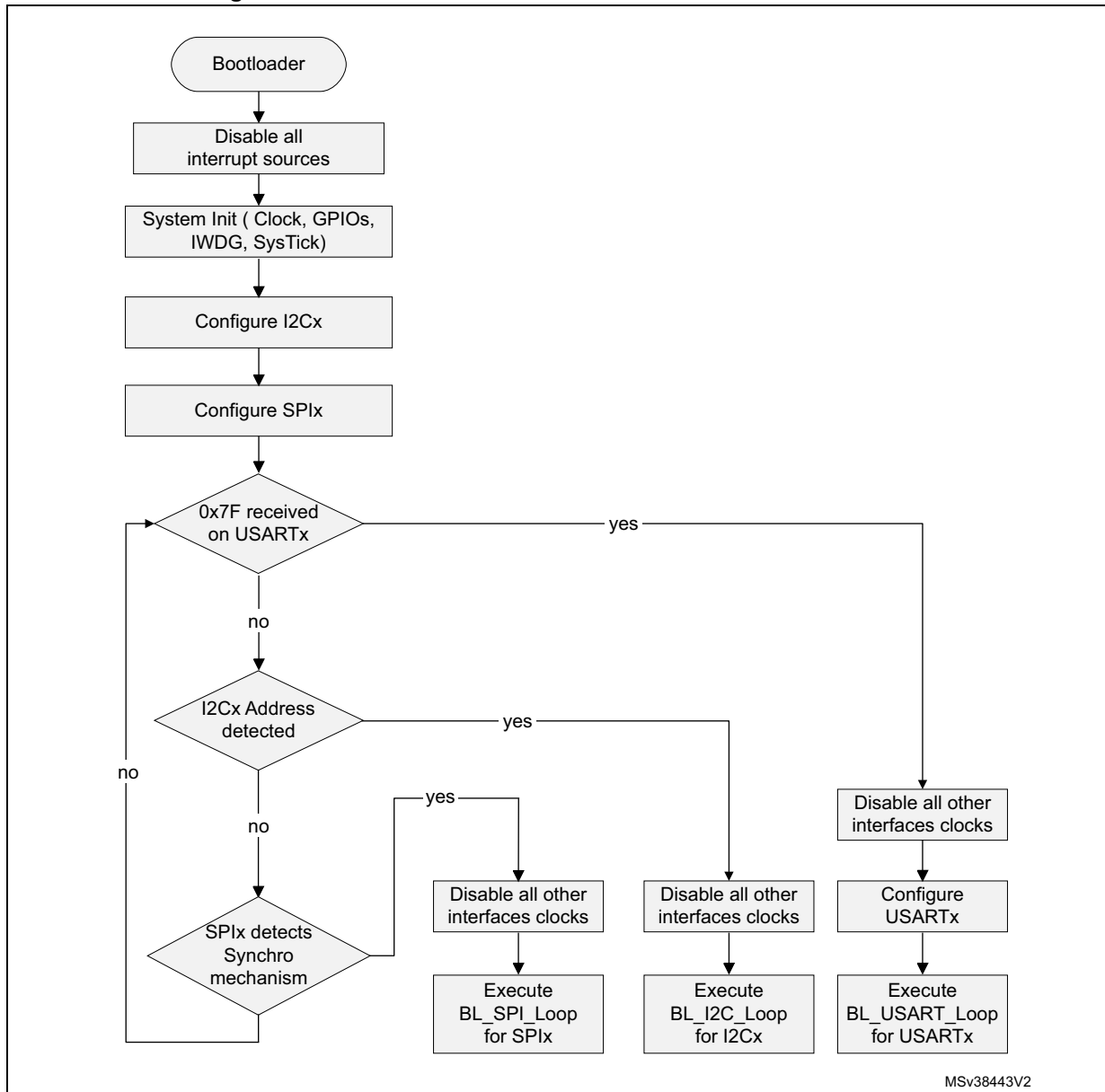

Figure 66. Bootloader V11.x selection for STM32L07xxx/08xxx



51.2.3 Bootloader version

The following table lists the STM32L07xxx/08xxx devices bootloader versions:

Table 112. STM32L07xxx/08xxx bootloader V11.x versions

Bootloader version number	Description	Known limitations
V11.1	Initial bootloader version	None
V11.2	This bootloader is an updated version of bootloader V11.1. This new version implements the Dual Bank Boot feature.	None

52 STM32L1xxx6(8/B)A devices bootloader

52.1 Bootloader configuration

The STM32L1xxx6(8/B)A bootloader is activated by applying Pattern 1 (described in [Table 2: Bootloader activation patterns](#)). The following table shows the hardware resources used by this bootloader.

Table 113. STM32L1xxx6(8/B)A configuration in system memory boot mode

Bootloader	Feature/Peripheral	State	Comment
Common to all bootloaders	RCC	HSI enabled	The system clock frequency is 16 MHz.
	RAM	-	2 Kbyte starting from address 0x20000000 are used by the bootloader firmware.
	System memory	-	4 Kbyte starting from address 0x1FF00000 contain the bootloader firmware.
	IWDG	-	The independent watchdog (IWDG) prescaler is configured to its maximum value and is periodically refreshed to prevent watchdog reset (in case the hardware IWDG option was previously enabled by the user).
	Power	-	Voltage range is set to Voltage Range 1.
USART1 bootloader	USART1	Enabled	Once initialized, the USART1 configuration is: 8 bits, even parity and 1 Stop bit.
	USART1_RX pin	Input	PA10 pin: USART1 in reception mode
	USART1_TX pin	Output	PA9 pin: USART1 in transmission mode
USART2 bootloader	USART2	Enabled	Once initialized, the USART2 configuration is: 8 bits, even parity and 1 Stop bit.
	USART2_RX pin	Input	PD6 pin: USART2 in reception mode
	USART2_TX pin	Output	PD5 pin: USART2 in transmission mode
USARTx bootloaders	SysTick timer	Enabled	Used to automatically detect the serial baud rate from the host.

The system clock is derived from the embedded internal high-speed RC, no external quartz is required for the bootloader execution.

52.2 Bootloader selection

The figure below shows the bootloader selection mechanism.

Figure 67. Bootloader selection for STM32L1xxx6(8/B)A devices

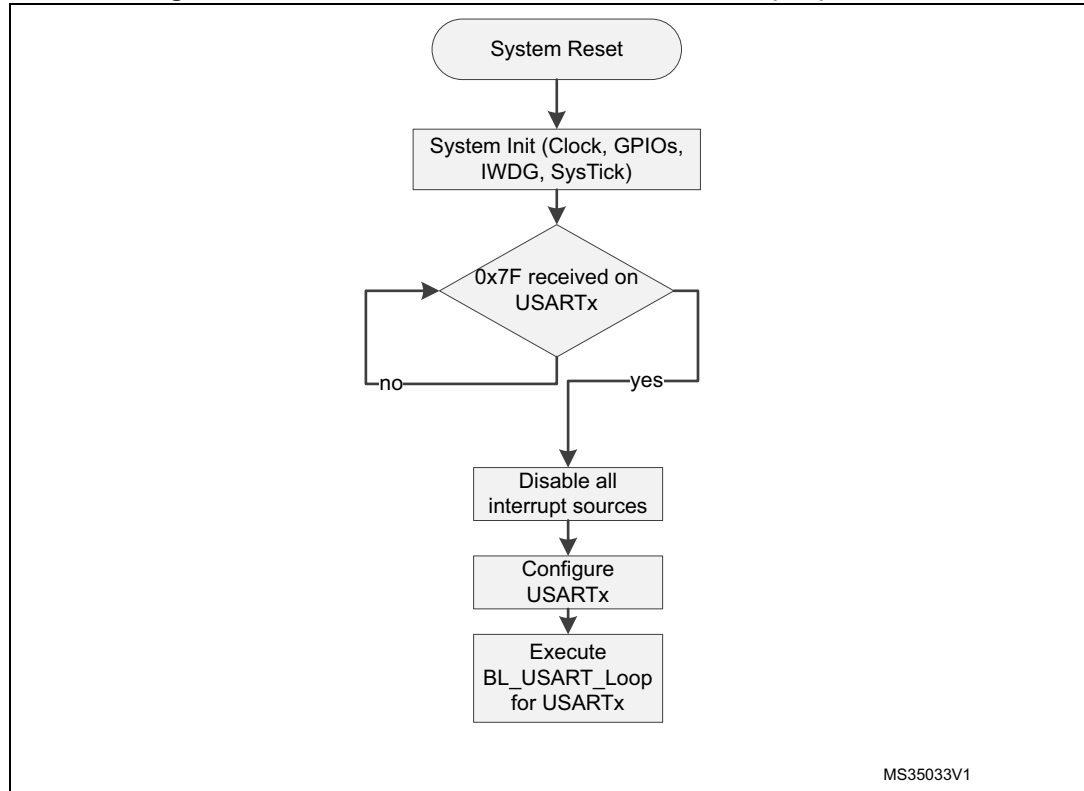

52.3 Bootloader version

The following table lists the STM32L1xxx6(8/B)A devices bootloader versions:

Table 114. STM32L1xxx6(8/B)A bootloader versions

Bootloader version number	Description	Known limitations
V2.0	Initial bootloader version	When a Read Memory command or Write Memory command is issued with an unsupported memory address and a correct address checksum (i.e. address 0x6000 0000), the command is aborted by the bootloader device, but the NACK (0x1F) is not sent to the host. As a result, the next 2 bytes (which are the number of bytes to be read/written and its checksum) are considered as a new command and its checksum. ⁽¹⁾

1. If the “number of data - 1” (N-1) to be read/written is not equal to a valid command code, then the limitation is not perceived from the host since the command is NACKed anyway (as an unsupported new command).

53 STM32L1xxx6(8/B) devices bootloader

53.1 Bootloader configuration

The STM32L1xxx6(8/B) bootloader is activated by applying Pattern 1 (described in [Table 2: Bootloader activation patterns](#)). The following table shows the hardware resources used by this bootloader.

Table 115. STM32L1xxx6(8/B) configuration in system memory boot mode

Bootloader	Feature/Peripheral	State	Comment
Common to all bootloaders	RCC	HSI enabled	The system clock frequency is 16 MHz.
	RAM	-	2 Kbyte starting from address 0x20000000 are used by the bootloader firmware.
	System memory	-	4 Kbyte starting from address 0x1FF00000 contain the bootloader firmware.
	IWDG	-	The independent watchdog (IWDG) prescaler is configured to its maximum value and is periodically refreshed to prevent watchdog reset (in case the hardware IWDG option was previously enabled by the user).
	Power	-	Voltage range is set to Voltage Range 1.
USART1 bootloader	USART1	Enabled	Once initialized, the USART1 configuration is: 8 bits, even parity and 1 Stop bit.
	USART1_RX pin	Input	PA10 pin: USART1 in reception mode
	USART1_TX pin	Output	PA9 pin: USART1 in transmission mode
USART2 bootloader	USART2	Enabled	Once initialized, the USART2 configuration is: 8 bits, even parity and 1 Stop bit.
	USART2_RX pin	Input	PD6 pin: USART2 in reception mode
	USART2_TX pin	Output	PD5 pin: USART2 in transmission mode
USARTx bootloaders	SysTick timer	Enabled	Used to automatically detect the serial baud rate from the host.

The system clock is derived from the embedded internal high-speed RC, no external quartz is required for the bootloader execution.

53.2 Bootloader selection

The figure below shows the bootloader selection mechanism.

Figure 68. Bootloader selection for STM32L1xxx6(8/B) devices

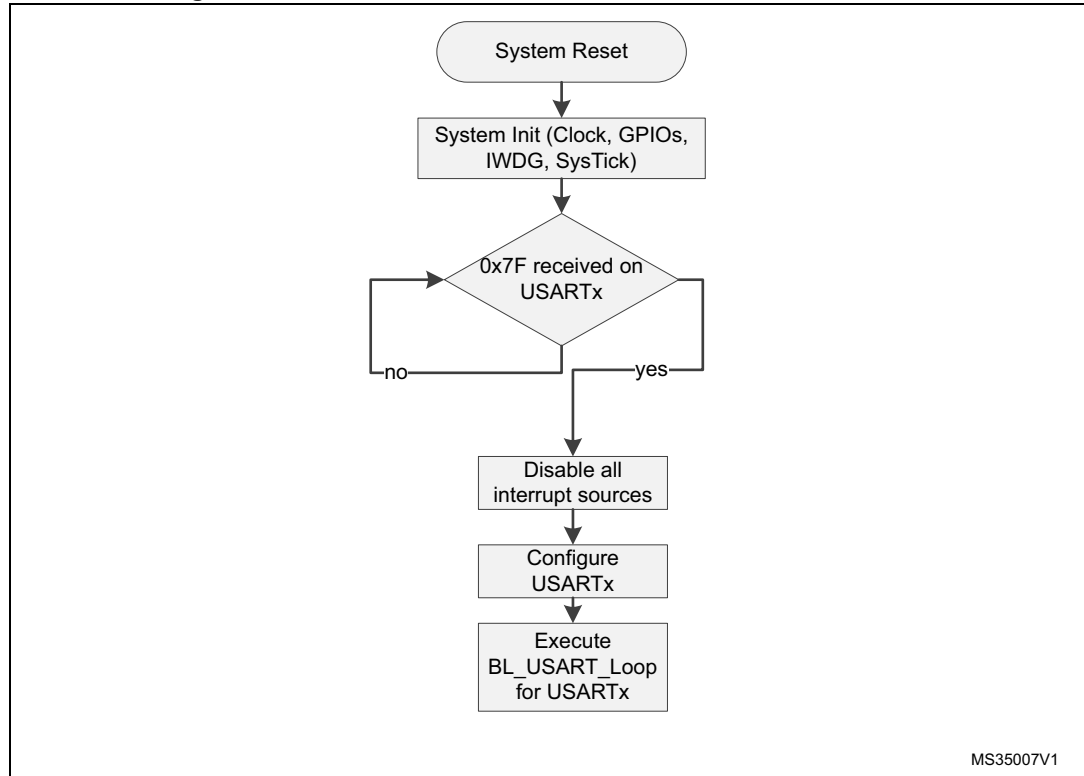

53.3 Bootloader version

The following table lists the STM32L1xxx6(8/B) devices bootloader versions:

Table 116. STM32L1xxx6(8/B) bootloader versions

Bootloader version number	Description	Known limitations
V2.0	Initial bootloader version	When a Read Memory command or Write Memory command is issued with an unsupported memory address and a correct address checksum (i.e. address 0x6000 0000), the command is aborted by the bootloader device, but the NACK (0x1F) is not sent to the host. As a result, the next 2 bytes (which are the number of bytes to be read/written and its checksum) are considered as a new command and its checksum. ⁽¹⁾

1. If the “number of data - 1” (N-1) to be read/written is not equal to a valid command code, then the limitation is not perceived from the host since the command is NACKed anyway (as an unsupported new command).

54 STM32L1xxxC devices bootloader

54.1 Bootloader configuration

The STM32L1xxxC bootloader is activated by applying Pattern 1 (described in [Table 2: Bootloader activation patterns](#)). The following table shows the hardware resources used by this bootloader.

Table 117. STM32L1xxxC configuration in system memory boot mode

Bootloader	Feature/Peripheral	State	Comment
Common to all bootloaders	RCC	HSI enabled	The system clock frequency is 16 MHz using the HSI. This is used only for USARTx bootloaders and during USB detection for DFU bootloader (once the DFU bootloader is selected, the clock source is derived from the external crystal).
		HSE enabled	The external clock is mandatory only for the DFU bootloader and must be in the following range: [24, 16, 12, 8, 6, 4, 3, 2] MHz. The PLL is used to generate the USB 48 MHz clock and the 32 MHz clock for the system clock.
		-	The Clock Security System (CSS) interrupt is enabled for the DFU bootloader. Any failure (or removal) of the external clock generates a system reset.
	RAM	-	4 Kbyte starting from address 0x20000000 are used by the bootloader firmware.
	System memory	-	8 Kbyte starting from address 0x1FF00000 contains the bootloader firmware.
	IWDG	-	The independent watchdog (IWDG) prescaler is configured to its maximum value and is periodically refreshed to prevent watchdog resets (in case the hardware IWDG option was previously enabled by the user).
	Power	-	Voltage range is set to Voltage Range 1.
USART1 bootloader	USART1	Enabled	Once initialized, the USART1 configuration is 8 bits, even parity and 1 stop bit.
	USART1_RX pin	Input	PA10 pin: USART1 in reception mode
	USART1_TX pin	Output	PA9 pin: USART1 in transmission mode
USART2 bootloader	USART2	Enabled	Once initialized, the USART2 configuration is 8 bits, even parity and 1 stop bit. The USART2 uses its remapped pins.
	USART2_RX pin	Input	PD6 pin: USART2 in reception mode
	USART2_TX pin	Output	PD5 pin: USART2 in transmission mode

Table 117. STM32L1xxxC configuration in system memory boot mode (continued)

Bootloader	Feature/Peripheral	State	Comment
USARTx bootloaders	SysTick timer	Enabled	Used to automatically detect the serial baud rate from the host for the USARTx bootloader.
DFU bootloader	USB	Enabled	USB used in FS mode
	USB_DM pin	Input/Output	PA11: USB DM line.
	USB_DP pin		PA12: USB DP line

The system clock is derived from the embedded internal high-speed RC for the USARTx bootloader. This internal clock is also used for the DFU bootloader but only for the selection phase. An external clock in the range of [24, 16, 12, 8, 6, 4, 3, 2] MHz is required for the execution of the DFU bootloader after the selection phase.

54.2 Bootloader selection

The figure below shows the bootloader selection mechanism.

Figure 69. Bootloader selection for STM32L1xxxC devices

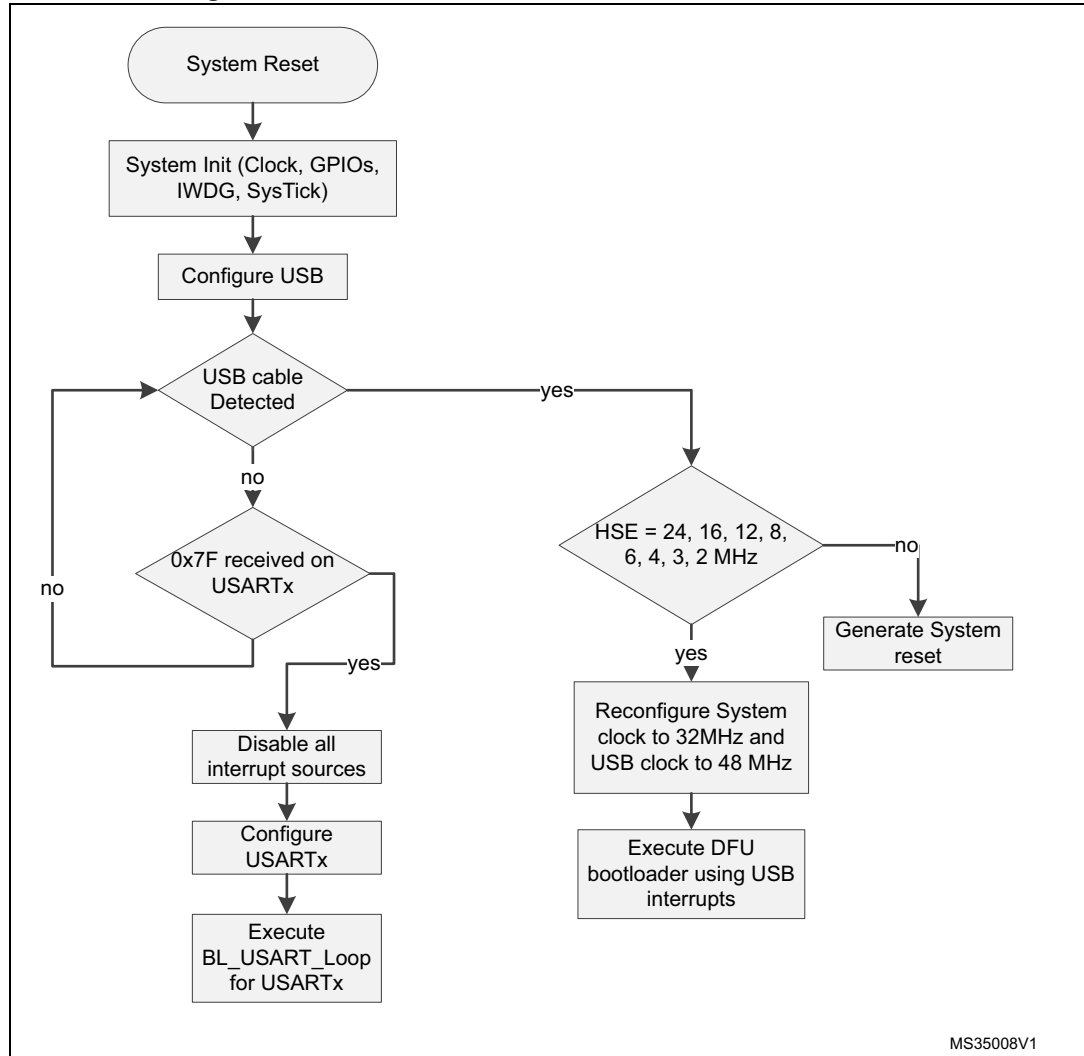

MS35008V1

54.3 Bootloader version

The following table lists the STM32L1xxxC devices bootloader versions.

Table 118. STM32L1xxxC bootloader versions

Bootloader version number	Description	Known limitations
V4.0	Initial bootloader version	For the USART interface, two consecutive NACKs instead of 1 NACK are sent when a Read Memory or Write Memory command is sent and the RDP level is active.

55 STM32L1xxxD devices bootloader

55.1 Bootloader configuration

The STM32L1xxxD bootloader is activated by applying pattern4 (described in [Table 2: Bootloader activation patterns](#)). The following table shows the hardware resources used by this bootloader.

Table 119. STM32L1xxxD configuration in system memory boot mode

Bootloader	Feature/Peripheral	State	Comment
Common to all bootloaders	RCC	HSI enabled	The system clock frequency is 16 MHz using the HSI. This is used only for USARTx bootloaders and during USB detection for DFU bootloader (once the DFU bootloader is selected, the clock source is derived from the external crystal).
		HSE enabled	The external clock is mandatory only for DFU bootloader and it must be in the following range: [24, 16, 12, 8, 6, 4, 3, 2] MHz. The PLL is used to generate the USB 48 MHz clock and the 32 MHz clock for the system clock.
		-	The Clock Security System (CSS) interrupt is enabled for the DFU bootloader. Any failure (or removal) of the external clock generates system reset.
	RAM	-	4 Kbyte starting from address 0x20000000 are used by the bootloader firmware.
	System memory	-	8 Kbyte starting from address 0x1FF00000 contains the bootloader firmware.
	IWDG	-	The independent watchdog (IWDG) prescaler is configured to its maximum value and is periodically refreshed to prevent watchdog reset (in case the hardware IWDG option was previously enabled by the user).
	Power	-	Voltage range is set to Voltage Range 1.
USART1 bootloader	USART1	Enabled	Once initialized, the USART1 configuration is: 8 bits, even parity and 1 Stop bit.
	USART1_RX pin	Input	PA10 pin: USART1 in reception mode
	USART1_TX pin	Output	PA9 pin: USART1 in transmission mode
USART2 bootloader	USART2	Enabled	Once initialized, the USART2 configuration is: 8 bits, even parity and 1 Stop bit. The USART2 uses its remapped pins.
	USART2_RX pin	Input	PD6 pin: USART2 in reception mode
	USART2_TX pin	Output	PD5 pin: USART2 in transmission mode

Table 119. STM32L1xxxD configuration in system memory boot mode (continued)

Bootloader	Feature/Peripheral	State	Comment
USARTx bootloaders	SysTick timer	Enabled	Used to automatically detect the serial baud rate from the host for USARTx bootloader.
DFU bootloader	USB	Enabled	USB used in FS mode
	USB_DM pin	Input/Output	PA11: USB DM line.
	USB_DP pin		PA12: USB DP line.

The system clock is derived from the embedded internal high-speed RC for USARTx bootloader. This internal clock is used also for DFU bootloader but only for the selection phase. An external clock in the range of [24, 16, 12, 8, 6, 4, 3, 2] MHz is required for DFU bootloader execution after the selection phase.

55.2 Bootloader selection

The figure below shows the bootloader selection mechanism.

Figure 70. Bootloader selection for STM32L1xxxD devices

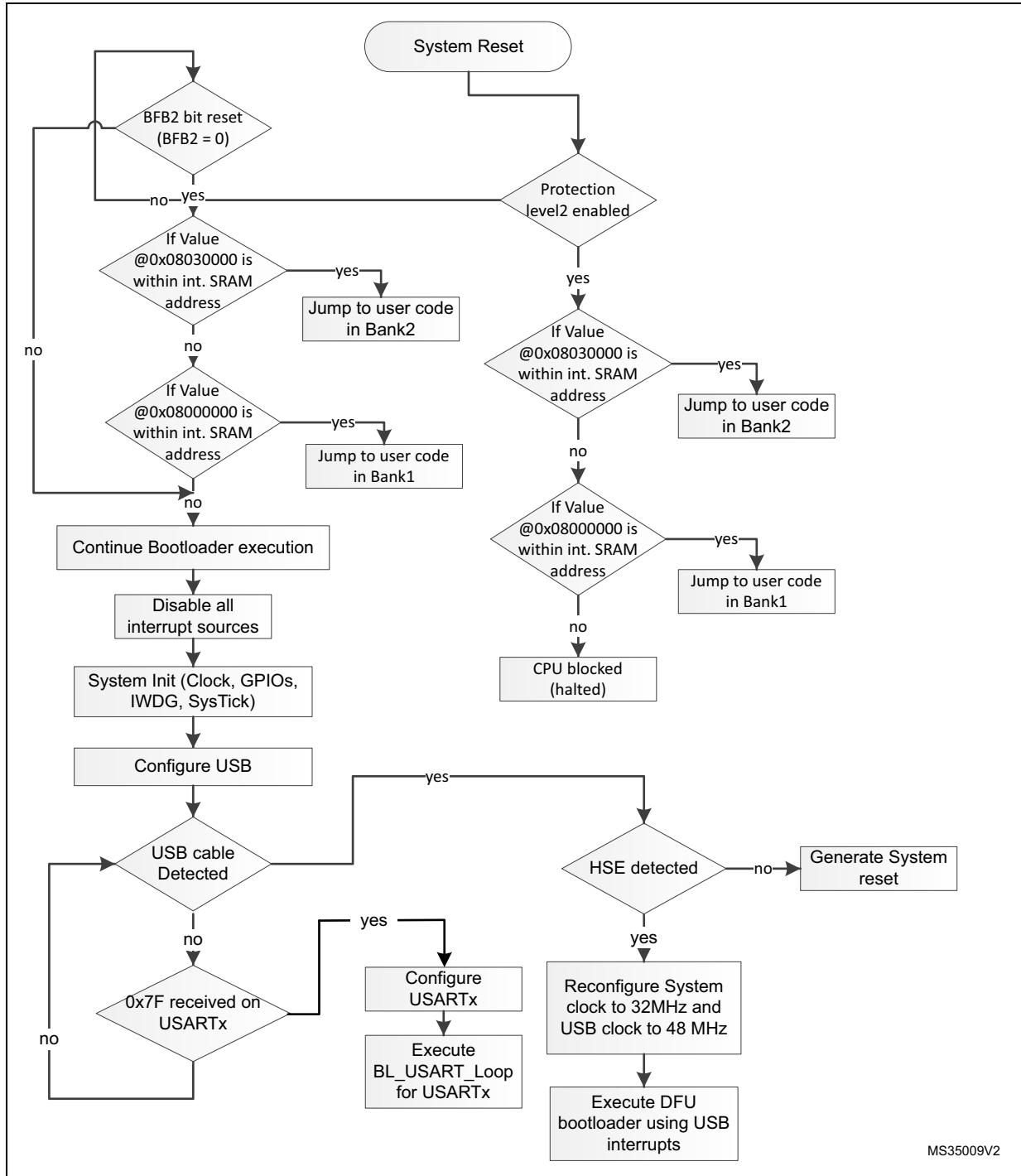

MS35009V2

55.3 Bootloader version

The following table lists the STM32L1xxxD devices bootloader versions:

Table 120. STM32L1xxxD bootloader versions

Bootloader version number	Description	Known limitations
V4.1	Initial bootloader version	<ul style="list-style-type: none"> - In the bootloader code the PA13 (JTMS/SWDIO) I/O output speed is configured to 400 kHz, as a consequence some debugger cannot connect to the device in Serial Wire mode when the bootloader is running. - When the DFU bootloader is selected, the RTC is reset and thus all RTC information (such as calendar, alarm) are lost including backup registers. Note: When the USART bootloader is selected there is no change on the RTC configuration (including backup registers).
V4.2	Fix V4.1 limitations (available on Rev.Z devices only)	<ul style="list-style-type: none"> - Stack overflow by 8 bytes when jumping to Bank1/Bank2 if BFB2=0 or when Read Protection level is set to 2. Workaround: the user code must force in the startup file the top of stack address before to jump to the main program. This can be done in the "Reset_Handler" routine. - When the Stack of the user code is placed outside the SRAM (i.e. @ 0x2000C000) the bootloader cannot jump to that user code which is considered invalid. This might happen when using compilers which place the stack at a non-physical address at the top of the SRAM (i.e. @ 0x2000C000). Workaround: place manually the stack at a physical address.
V4.5	Fix V4.2 limitations. DFU interface robustness enhancements (available on Rev.Y devices only).	<ul style="list-style-type: none"> - For the USART interface, two consecutive NACKs (instead of 1 NACK) are sent when a Read Memory or Write Memory command is sent and the RDP level is active.

56 STM32L1xxxE devices bootloader

56.1 Bootloader configuration

The STM32L1xxxE bootloader is activated by applying pattern 4 (described in [Table 2: Bootloader activation patterns](#)). The following table shows the hardware resources used by this bootloader.

Table 121. STM32L1xxxE configuration in system memory boot mode

Bootloader	Feature/Peripheral	State	Comment
Common to all bootloaders	RCC	HSI enabled	The system clock frequency is 16 MHz using the HSI. This is used only for USARTx bootloaders and during USB detection for DFU bootloader (once the DFU bootloader is selected, the clock source is derived from the external crystal).
		HSE enabled	The external clock is mandatory only for DFU bootloader and it must be in the following range: [24, 16, 12, 8, 6, 4, 3, 2] MHz. The PLL is used to generate the USB 48 MHz clock and the 32 MHz clock for the system clock.
		-	The Clock Security System (CSS) interrupt is enabled for the DFU bootloader. Any failure (or removal) of the external clock generates system reset.
	RAM	-	4 Kbyte starting from address 0x20000000 are used by the bootloader firmware.
	System memory	-	8 Kbyte starting from address 0x1FF00000 contains the bootloader firmware.
	IWDG	-	The independent watchdog (IWDG) prescaler is configured to its maximum value and is periodically refreshed to prevent watchdog reset (in case the hardware IWDG option was previously enabled by the user).
	Power	-	Voltage range is set to Voltage Range 1.
USART1 bootloader	USART1	Enabled	Once initialized, the USART1 configuration is: 8 bits, even parity and 1 Stop bit.
	USART1_RX pin	Input	PA10 pin: USART1 in reception mode
	USART1_TX pin	Output	PA9 pin: USART1 in transmission mode
USART2 bootloader	USART2	Enabled	Once initialized, the USART2 configuration is: 8 bits, even parity and 1 Stop bit. The USART2 uses its remapped pins.
	USART2_RX pin	Input	PD6 pin: USART2 in reception mode
	USART2_TX pin	Output	PD5 pin: USART2 in transmission mode

Table 121. STM32L1xxxE configuration in system memory boot mode (continued)

Bootloader	Feature/Peripheral	State	Comment
USARTx bootloaders	SysTick timer	Enabled	Used to automatically detect the serial baud rate from the host for USARTx bootloader.
DFU bootloader	USB	Enabled	USB used in FS mode
	USB_DM pin	Input/Output	PA11: USB DM line.
	USB_DP pin		PA12: USB DP line.

The system clock is derived from the embedded internal high-speed RC for USARTx bootloader. This internal clock is used also for DFU bootloader but only for the selection phase. An external clock in the range of [24, 16, 12, 8, 6, 4, 3, 2] MHz is required for DFU bootloader execution after the selection phase.

56.2 Bootloader selection

The figure below shows the bootloader selection mechanism.

Figure 71. Bootloader selection for STM32L1xxxE devices

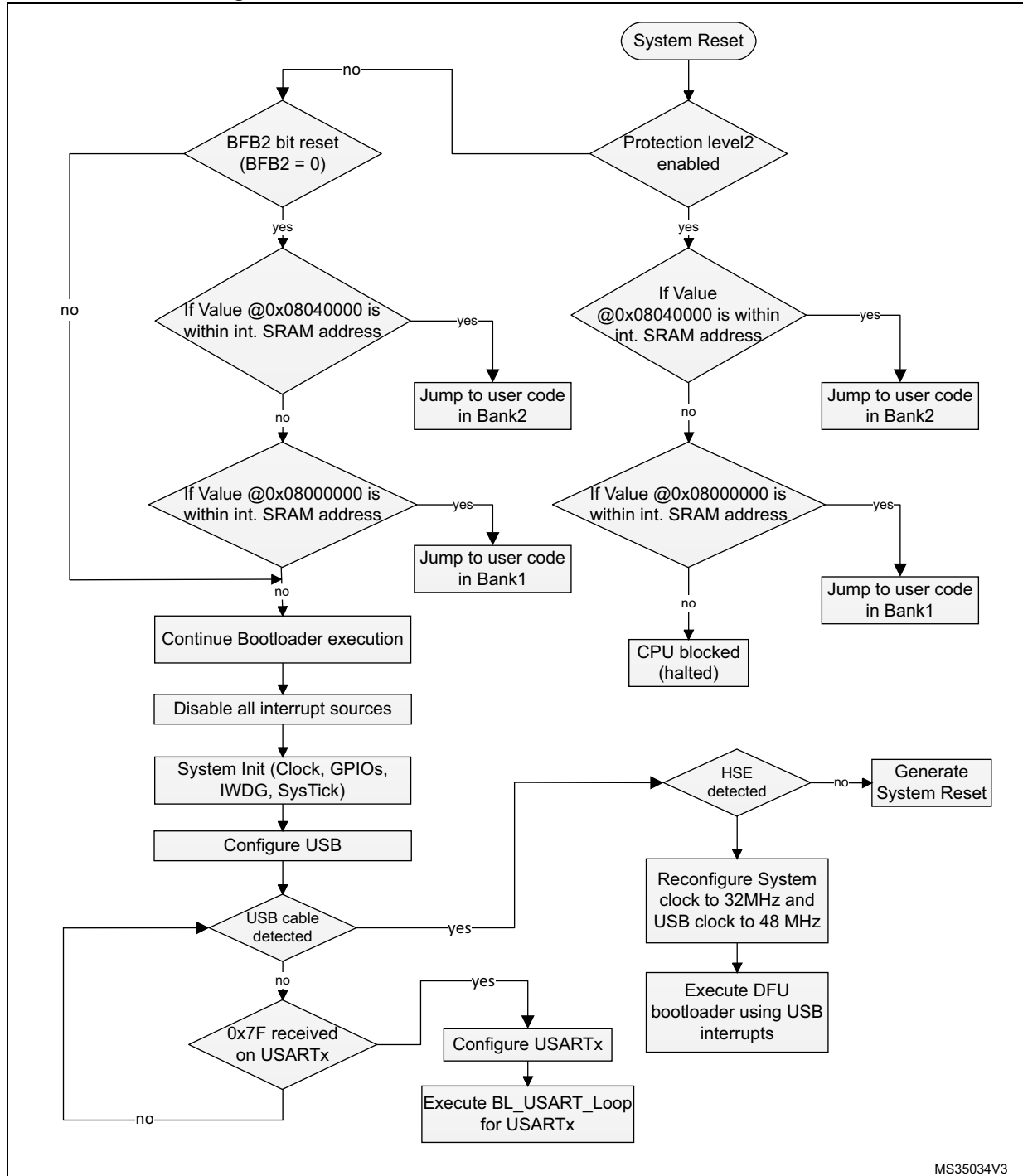

MS35034V3

56.3 Bootloader version

The following table lists the STM32L1xxxE devices bootloader versions:

Table 122. STM32L1xxxE bootloader versions

Bootloader version number	Description	Known limitations
V4.0	Initial bootloader version	For the USART interface, two consecutive NACKs (instead of 1 NACK) are sent when a Read Memory or Write Memory command is sent and the RDP level is active.

57 STM32L412xx/422xx devices bootloader

57.1 Bootloader configuration

The STM32L412xx/422xx bootloader is activated by applying Pattern 6 (described in [Table 2: Bootloader activation patterns](#)). The following table shows the hardware resources used by this bootloader.

Table 123. STM32L412xx/422xx configuration in system memory boot mode

Bootloader	Feature/Peripheral	State	Comment
Common to all bootloaders	RCC	HSI enabled	The HSI is used at startup as clock source for system clock configured to 72 MHz and for USART, I2C, SPI and USB bootloader operation.
		-	The clock recovery system (CRS) is enabled for the DFU bootloader to allow USB to be clocked by HSI48 48 MHz.
	RAM	-	12 Kbyte starting from address 0x20000000 are used by the bootloader firmware
	System memory	-	28 Kbyte starting from address 0x1FFF0000, contain the bootloader firmware
	IWDG	-	The independent watchdog (IWDG) prescaler is configured to its maximum value. It is periodically refreshed to prevent watchdog reset (in case the hardware IWDG option was previously enabled by the user).
	Power	-	The DFU cannot be used to communicate with bootloader if the voltage scaling range 2 is selected. Bootloader firmware does not configure voltage scaling range value in PWR_CR1 register.
USART1 bootloader	USART1	Enabled	Once initialized the USART1 configuration is: 8-bit, even parity and 1 Stop bit
	USART1_RX pin	Input	PA10 pin: USART1 in reception mode
	USART1_TX pin	Output	PA9 pin: USART1 in transmission mode
USART2 bootloader	USART2	Enabled	Once initialized the USART2 configuration is: 8-bit, even parity and 1 Stop bit
	USART2_RX pin	Input	PA3 pin: USART2 in reception mode
	USART2_TX pin	Output	PA2 pin: USART2 in transmission mode
USART3 bootloader	USART3	Enabled	Once initialized the USART3 configuration is: 8-bit, even parity and 1 Stop bit
	USART3_RX pin	Input	PC11 pin: USART3 in reception mode
	USART3_TX pin	Output	PC10 pin: USART3 in transmission mode
USARTx bootloaders	SysTick timer	Enabled	Used to automatically detect the serial baud rate from the host for USARTx bootloaders.

Table 123. STM32L412xx/422xx configuration in system memory boot mode (continued)

Bootloader	Feature/Peripheral	State	Comment
I2C1 bootloader	I2C1	Enabled	The I2C1 configuration is: I2C speed: up to 1 MHz, 7-bit address, slave mode, analog filter ON. Slave 7-bit address: 0b1010010x (where x = 0 for write and x = 1 for read)
	I2C1_SCL pin	Input/Output	PB6 pin: clock line is used in open-drain mode.
	I2C1_SDA pin	Input/Output	PB7 pin: data line is used in open-drain mode.
I2C2 bootloader	I2C2	Enabled	The I2C2 configuration is: I2C speed: up to 1 MHz, 7-bit address, slave mode, analog filter ON. Slave 7-bit address: 0b1010010x (where x = 0 for write and x = 1 for read)
	I2C2_SCL pin	Input/Output	PB10 pin: clock line is used in open-drain mode.
	I2C2_SDA pin	Input/Output	PB11 pin: data line is used in open-drain mode.
I2C3 bootloader	I2C3	Enabled	The I2C3 configuration is: I2C speed: up to 1 MHz, 7-bit address, slave mode, analog filter ON. Slave 7-bit address: 0b1010010x (where x = 0 for write and x = 1 for read)
	I2C3_SCL pin	Input/Output	PC0 pin: clock line is used in open-drain mode.
	I2C3_SDA pin	Input/Output	PC1 pin: data line is used in open-drain mode.
SPI1 bootloader	SPI1	Enabled	The SPI1 configuration is: – Slave mode – Full Duplex – 8-bit MSB – Speed up to 8 MHz – Polarity: CPOL Low, CPHA Low, NSS hardware.
	SPI1_MOSI pin	Input	PA7 pin: Slave data Input line, used in push-pull, pull-down mode
	SPI1_MISO pin	Output	PA6 pin: Slave data output line, used in push-pull, pull-down mode
	SPI1_SCK pin	Input	PA5 pin: Slave clock line, used in push-pull, pull-down mode
	SPI1_NSS pin	Input	PA4 pin: slave chip select pin used in push-pull, pull-down mode. Note: This IO can be tied to GND if the SPI Master does not use it.

Table 123. STM32L412xx/422xx configuration in system memory boot mode (continued)

Bootloader	Feature/Peripheral	State	Comment
SPI2 bootloader	SPI2	Enabled	The SPI2 configuration is: – Slave mode – Full Duplex – 8-bit MSB – Speed up to 8 MHz Polarity: CPOL Low, CPHA Low, NSS hardware
	SPI2_MOSI pin	Input	PB15 pin: Slave data Input line, used in push-pull, pull-down mode
	SPI2_MISO pin	Output	PB14 pin: Slave data output line, used in push-pull, pull-down mode
	SPI2_SCK pin	Input	PB13 pin: Slave clock line, used in push-pull, pull-down mode
	SPI2_NSS pin	Input	PB12 pin: slave chip select pin used in push-pull, pull-down mode. Note: This IO can be tied to GND if the SPI Master does not use it.
DFU bootloader	USB	Enabled	USB FS configured in forced device mode. USB FS interrupt vector is enabled and used for USB DFU communications. Note: VDDUSB IO must be connected to 3.3 V as USB peripheral is used by the bootloader.
	USB_DM pin	Input/Output	PA11: USB DM line.
	USB_DP pin		PA12: USB DP line No external pull-up resistor is required

Note: If VDDUSB pin is not connected to VDD, then SPI Flash memory write operations may be corrupted due to voltage issue. For more details, please refer to product's datasheet and errata sheet.

57.2 Bootloader selection

The figures below show the bootloader selection mechanism.

Figure 72. Dual bank boot Implementation for STM32L412xx/422xx bootloader V9.x

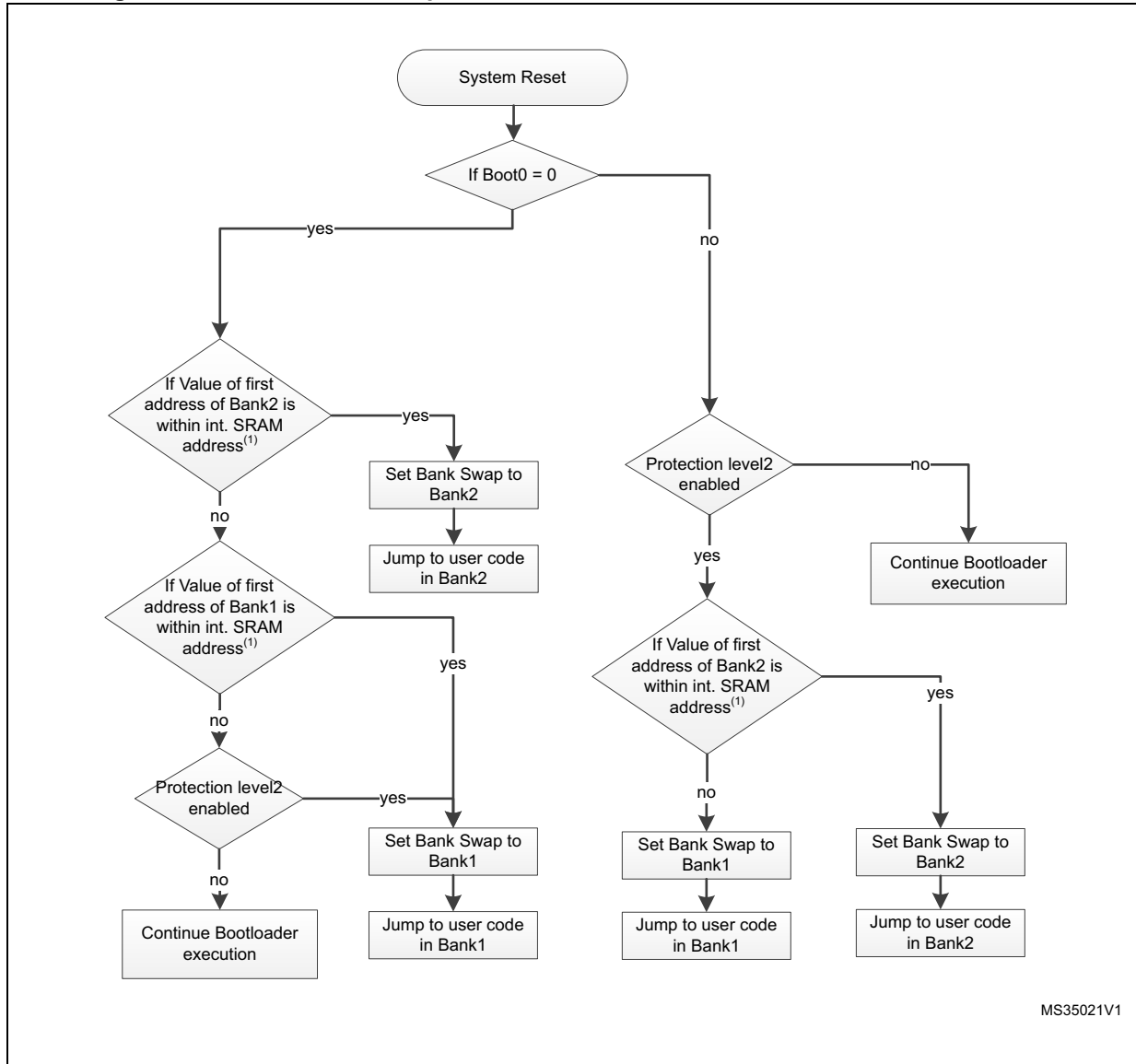
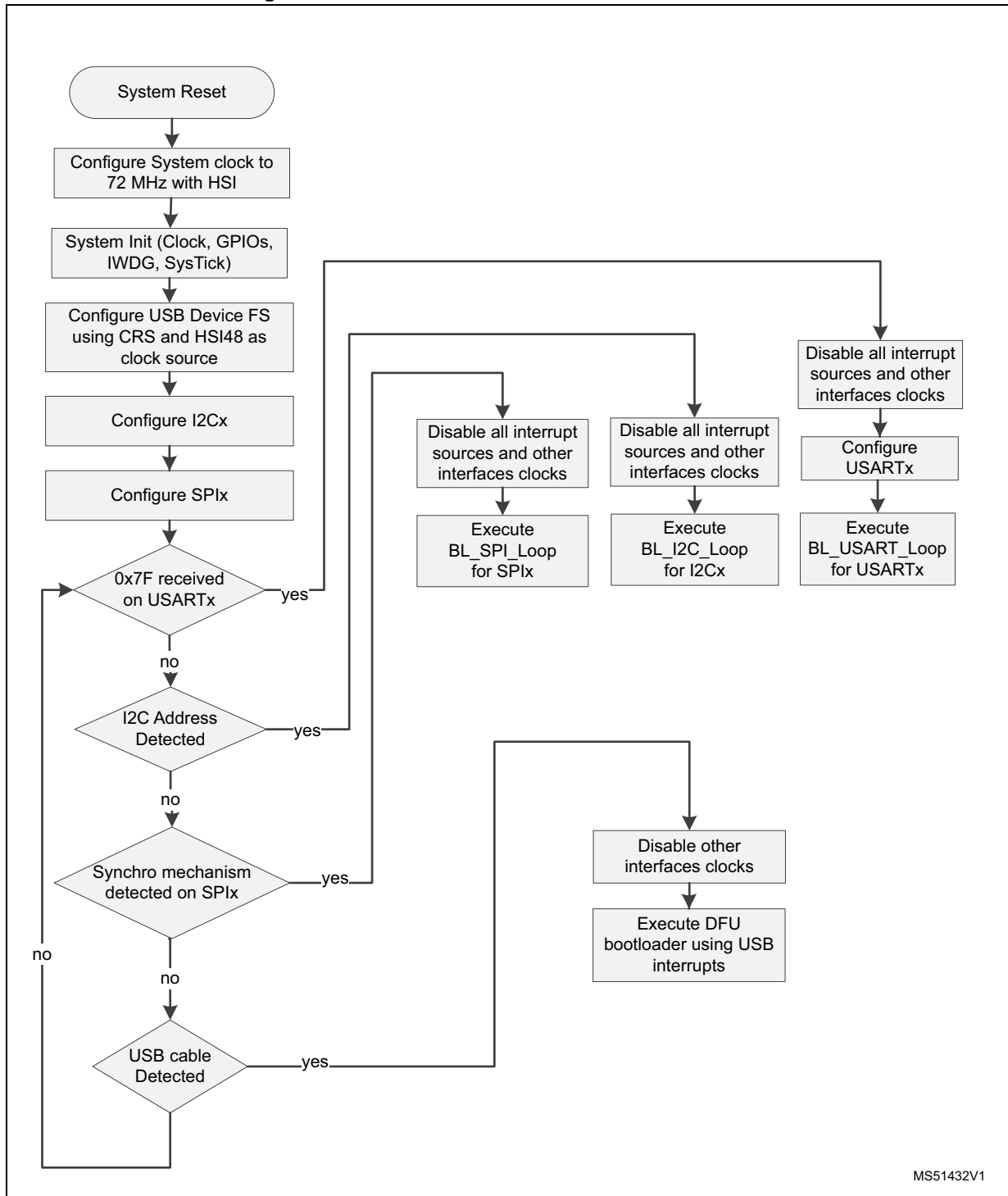

Figure 73.Bootloader V13.x selection for STM32L412xx/422xx



MS51432V1

57.3 Bootloader version

Table 124 lists the STM32L412xx/422xx devices bootloader version.

Table 124. STM32L412xx/422xx bootloader versions

Bootloader version number	Description	Known limitations
V13.1	Initial bootloader version	<ul style="list-style-type: none"> – On connection phase, USART responds with two ACK bytes (0x79) instead of only one. – PcROP option bytes cannot be written as Bootloader uses Byte access while PcROP must be accessed using Half-Word access. Workaround: load a code snippet in SRAM using Bootloader interface then jump to it, and that code would write PcROP value.

58 STM32L43xxx/44xxx devices bootloader

58.1 Bootloader configuration

The bootloader V9.1 version is updated to fix known limitations relative to USB-DFU interface, and is implemented on devices with version information ID equal to 0x10 (refer to [Table 126](#) for more details).

The STM32L43xxx/44xxx bootloader is activated by applying Pattern 6 (described in [Table 2: Bootloader activation patterns](#)). The following table shows the hardware resources used by this bootloader.

Table 125. STM32L43xxx/44xxx configuration in system memory boot mode

Bootloader	Feature/Peripheral	State	Comment
Common to all bootloaders	RCC	HSI enabled	The HSI is used at startup as clock source for system clock configured to 60 MHz and for USART, I2C, SPI and USB bootloader operation.
		-	The clock recovery system (CRS) is enabled for the DFU bootloader to allow USB to be clocked by HSI48 48 MHz.
		HSE enabled	The HSE is used only when the CAN interface is selected. The HSE must have one of the following values [24,20,18,16,12,9,8,6,4] MHz.
		-	The Clock Security System (CSS) interrupt is enabled when HSE is enabled. Any failure (or removal) of the external clock generates system reset
	RAM	-	12 Kbyte starting from address 0x20000000 are used by the bootloader firmware
	System memory	-	28 Kbyte starting from address 0x1FFF0000, contain the bootloader firmware
	IWDG	-	The independent watchdog (IWDG) prescaler is configured to its maximum value. It is periodically refreshed to prevent watchdog reset (in case the hardware IWDG option was previously enabled by the user).
	Power	-	The DFU cannot be used to communicate with bootloader if the voltage scaling range 2 is selected. Bootloader firmware does not configure voltage scaling range value in PWR_CR1 register.
USART1 bootloader	USART1	Enabled	Once initialized the USART1 configuration is: 8-bit, even parity and 1 Stop bit
	USART1_RX pin	Input	PA10 pin: USART1 in reception mode
	USART1_TX pin	Output	PA9 pin: USART1 in transmission mode

Table 125. STM32L43xxx/44xxx configuration in system memory boot mode (continued)

Bootloader	Feature/Peripheral	State	Comment
USART2 bootloader	USART2	Enabled	Once initialized the USART2 configuration is: 8-bit, even parity and 1 Stop bit
	USART2_RX pin	Input	PA3 pin: USART2 in reception mode
	USART2_TX pin	Output	PA2 pin: USART2 in transmission mode
USART3 bootloader	USART3	Enabled	Once initialized the USART3 configuration is: 8-bit, even parity and 1 Stop bit
	USART3_RX pin	Input	PC11 pin: USART3 in reception mode
	USART3_TX pin	Output	PC10 pin: USART3 in transmission mode
USARTx bootloaders	SysTick timer	Enabled	Used to automatically detect the serial baud rate from the host for USARTx bootloaders.
I2C1 bootloader	I2C1	Enabled	The I2C1 configuration is: I2C speed: up to 1 MHz, 7-bit address, slave mode, analog filter ON. Slave 7-bit address: 0b1001000x (where x = 0 for write and x = 1 for read)
	I2C1_SCL pin	Input/Output	PB6 pin: clock line is used in open-drain mode.
	I2C1_SDA pin	Input/Output	PB7 pin: data line is used in open-drain mode.
I2C2 bootloader	I2C2	Enabled	The I2C2 configuration is: I2C speed: up to 1 MHz, 7-bit address, slave mode, analog filter ON. Slave 7-bit address: 0b1001000x (where x = 0 for write and x = 1 for read)
	I2C2_SCL pin	Input/Output	PB10 pin: clock line is used in open-drain mode.
	I2C2_SDA pin	Input/Output	PB11 pin: data line is used in open-drain mode.
I2C3 bootloader	I2C3	Enabled	The I2C3 configuration is: I2C speed: up to 1 MHz, 7-bit address, slave mode, analog filter ON. Slave 7-bit address: 0b1001000x (where x = 0 for write and x = 1 for read)
	I2C3_SCL pin	Input/Output	PC0 pin: clock line is used in open-drain mode.
	I2C3_SDA pin	Input/Output	PC1 pin: data line is used in open-drain mode.

Table 125. STM32L43xxx/44xxx configuration in system memory boot mode (continued)

Bootloader	Feature/Peripheral	State	Comment
SPI1 bootloader	SPI1	Enabled	The SPI1 configuration is: – Slave mode – Full Duplex – 8-bit MSB – Speed up to 8 MHz – Polarity: CPOL Low, CPHA Low, NSS hardware.
	SPI1_MOSI pin	Input	PA7 pin: Slave data Input line, used in push-pull, pull-down mode
	SPI1_MISO pin	Output	PA6 pin: Slave data output line, used in push-pull, pull-down mode
	SPI1_SCK pin	Input	PA5 pin: Slave clock line, used in push-pull, pull-down mode
	SPI1_NSS pin	Input	PA4 pin: slave chip select pin used in push-pull, pull-down mode. Note: This IO can be tied to GND if the SPI Master does not use it.
SPI2 bootloader	SPI2	Enabled	The SPI2 configuration is: – Slave mode – Full Duplex – 8-bit MSB – Speed up to 8 MHz Polarity: CPOL Low, CPHA Low, NSS hardware
	SPI2_MOSI pin	Input	PB15 pin: Slave data Input line, used in push-pull, pull-down mode
	SPI2_MISO pin	Output	PB14 pin: Slave data output line, used in push-pull, pull-down mode
	SPI2_SCK pin	Input	PB13 pin: Slave clock line, used in push-pull, pull-down mode
	SPI2_NSS pin	Input	PB12 pin: slave chip select pin used in push-pull, pull-down mode. Note: This IO can be tied to GND if the SPI Master does not use it.
CAN1 bootloader	CAN1	Enabled	Once initialized the CAN1 configuration is: Baudrate 125 kbps, 11 -bit identifier.
	CAN1_RX pin	Input	PB8 pin: CAN1 in reception mode
	CAN1_TX pin	Output	PB9 pin: CAN1 in transmission mode
	TIM16	Enabled	This timer is used to determine the value of the HSE. Once the HSE frequency is determined, the system clock is configured to 60 MHz using PLL and HSE.

Table 125. STM32L43xxx/44xxx configuration in system memory boot mode (continued)

Bootloader	Feature/Peripheral	State	Comment
DFU bootloader	USB	Enabled	USB FS configured in forced device mode. USB FS interrupt vector is enabled and used for USB DFU communications. Note: VDDUSB IO must be connected to 3.3 V as USB peripheral is used by the bootloader.
	USB_DM pin	Input/Output	PA11: USB DM line.
	USB_DP pin		PA12: USB DP line No external pull-up resistor is required

Note: If VDDUSB pin is not connected to VDD, then SPI Flash memory write operations may be corrupted due to voltage issue. For more details, please refer to product's datasheet and errata sheet.

58.2 Bootloader selection

The figures below show the bootloader selection mechanism.

Figure 74. Dual bank boot Implementation for STM32L3x2xx/44xxx bootloader V9.x

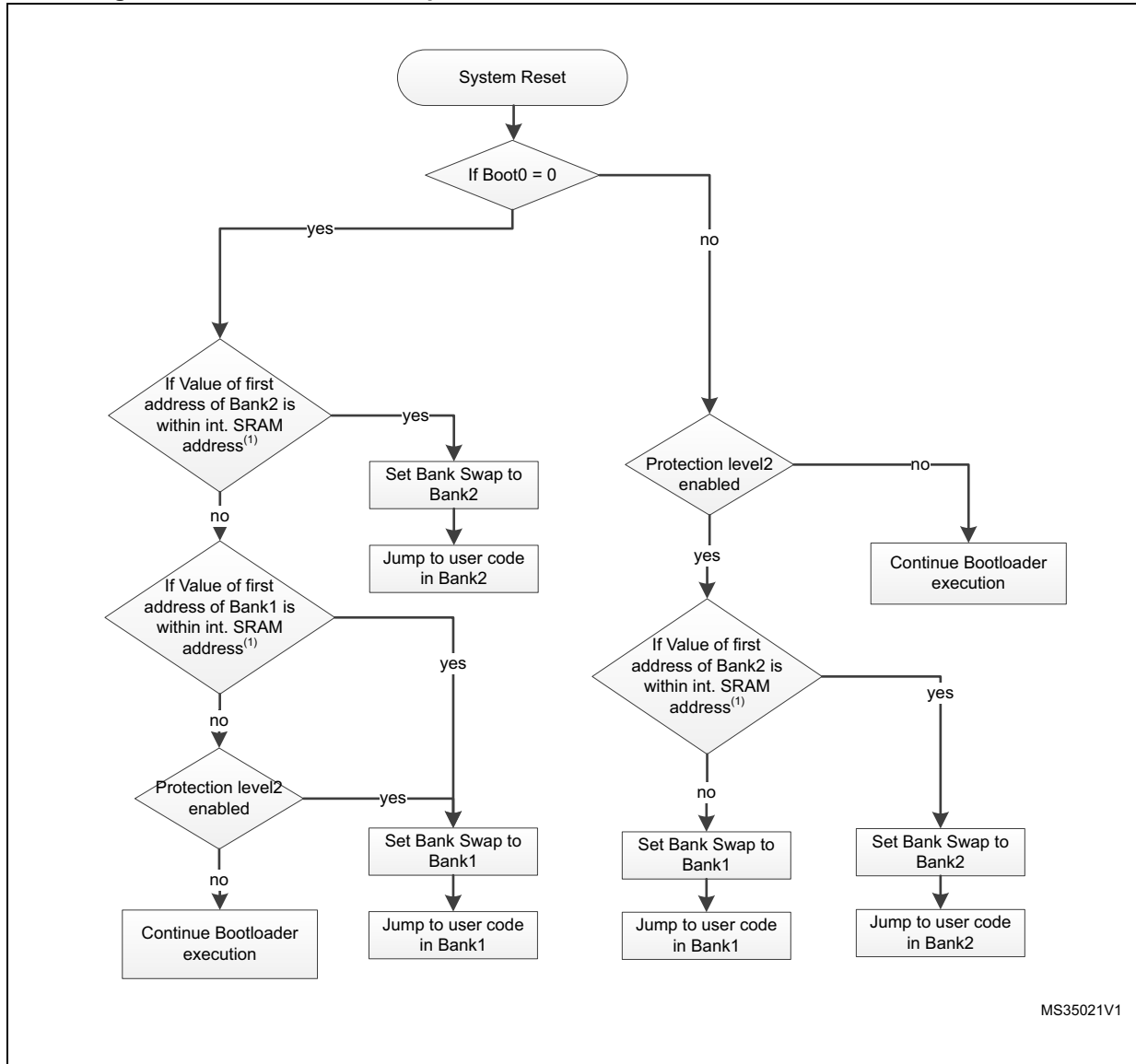
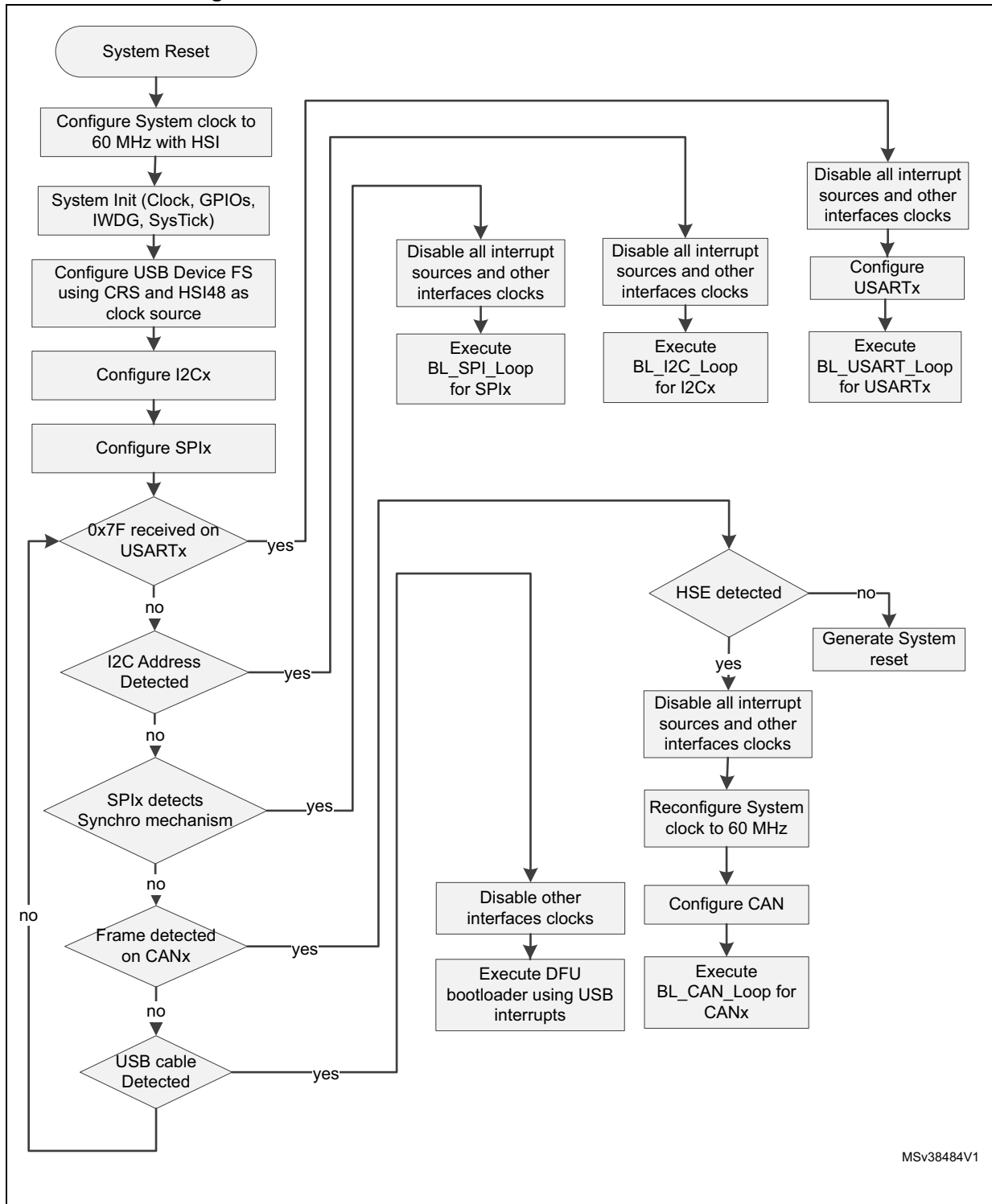

Figure 75. Bootloader V9.x selection for STM32L43xxx/44xxx



58.3 Bootloader version

[Table 126](#) lists the STM32L43xxx/44xxx devices bootloader versions.

Table 126. STM32L43xxx/44xxx bootloader versions

Bootloader version number	Description	Known limitations
V9.1	Initial bootloader version	<p>Check the Version Information ID of your STM32L43xxx/44xxx device, which can be read at 0x1FFF6FF2 address.</p> <p>Version Information ID equal to 0xFF:</p> <ul style="list-style-type: none"> – For memory write operations using DFU interface: If the buffer size is larger than 256 bytes and not multiple of 8 bytes, the write memory operation result is corrupted. Workaround: if the file size is larger than 256 bytes, add byte padding to align it on 8-bytes multiple size. – For the USB-DFU interface, the CRS (clock recovery system) is not correctly configured and this may lead to random USB communication errors (depending on temperature and voltage). In most case communication error will manifest by a "Stall" response to setup packets. – On the "Go" command, system bootloader de-init clears the RTCAPBEN bit in the RCC_APB1ENR register Workaround: manually call <code>__HAL_RCC_RTC_CLK_ENABLE()</code> in the software which sets the RTCAPBEN bit. <p>Version Information ID equal to 0x10: None</p> <ul style="list-style-type: none"> – PcROP option bytes cannot be written as Bootloader uses Byte access while PcROP must be accessed using Half-Word access. Workaround: load a code snippet in SRAM using Bootloader interface then jump to it, and that code would write PcROP value.

Table 126. STM32L43xxx/44xxx bootloader versions

Bootloader version number	Description	Known limitations
V9.1 (continued)	Initial bootloader version (continued)	<ul style="list-style-type: none"> - SPI write operation fail Limitation: <ul style="list-style-type: none"> a. During bootloader SPI write Flash memory operation, some random 64-bits (2 double-words) may be left blank at 0xFF. Root cause: <ul style="list-style-type: none"> a. Bootloader uses 64-bits cast write operation which is interrupted by SPI DMA and it leads to double access on same Flash memory address and the 64-bits are not written. Workarounds: <ul style="list-style-type: none"> a. WA1: add a delay between sending write command and its ACK request. Its duration must be the duration of the 256-Bytes Flash memory write time. b. WA2: read back after write and in case of error start write again. c. WA3: Patch in RAM to write in Flash memory that implements write memory without 64-bits cast. WA1 and WA3 are more efficient than WA2 in terms of total programming time. How critical is the limitation: <ul style="list-style-type: none"> a. The limitation leads to a modification in customer SPI host software by adding 3-4 ms delay to each write operation. b. The delay is not waste because it is anyway the Flash memory write period of time that host has to wait anyway (so instead of waiting by sending ACK requests, host will wait by delay). c. Limitation has been seen only on SPI and cannot impact USART/I2C/CAN

59 STM32L45xxx/46xxx devices bootloader

59.1 Bootloader configuration

The STM32L45xxx/46xxx bootloader is activated by applying Pattern 6 (described in [Table 2: Bootloader activation patterns](#)). The following table shows the hardware resources used by this bootloader.

Table 127. STM32L45xxx/46xxx configuration in system memory boot mode

Bootloader	Feature/Peripheral	State	Comment
Common to all bootloaders	RCC	HSI enabled	The HSI is used at startup as clock source for system clock configured to 72 MHz and for USART, I2C, SPI and USB bootloader operation.
		-	The clock recovery system (CRS) is enabled for the DFU bootloader to allow USB to be clocked by HSI48 48 MHz.
		HSE enabled	The system clock frequency is 60 MHz. The HSE is used only when the CAN interface is selected. The HSE must have one of the following values [24,20,18,16,12,9,8,6,4] MHz.
		-	The Clock Security System (CSS) interrupt is enabled when HSE is enabled. Any failure (or removal) of the external clock generates system reset
	RAM	-	12 Kbyte starting from address 0x20000000 are used by the bootloader firmware
	System memory	-	28 Kbyte starting from address 0x1FFF0000, contain the bootloader firmware
	IWDG	-	The independent watchdog (IWDG) prescaler is configured to its maximum value. It is periodically refreshed to prevent watchdog reset (in case the hardware IWDG option was previously enabled by the user).
Power	-	The DFU cannot be used to communicate with bootloader if the voltage scaling range 2 is selected. Bootloader firmware does not configure voltage scaling range value in PWR_CR1 register.	
USART1 bootloader	USART1	Enabled	Once initialized the USART1 configuration is: 8-bit, even parity and 1 Stop bit
	USART1_RX pin	Input	PA10 pin: USART1 in reception mode
	USART1_TX pin	Output	PA9 pin: USART1 in transmission mode

Table 127. STM32L45xxx/46xxx configuration in system memory boot mode (continued)

Bootloader	Feature/Peripheral	State	Comment
USART2 bootloader	USART2	Enabled	Once initialized the USART2 configuration is: 8-bit, even parity and 1 Stop bit
	USART2_RX pin	Input	PA3 pin: USART2 in reception mode
	USART2_TX pin	Output	PA2 pin: USART2 in transmission mode
USART3 bootloader	USART3	Enabled	Once initialized the USART3 configuration is: 8-bit, even parity and 1 Stop bit
	USART3_RX pin	Input	PC11 pin: USART3 in reception mode
	USART3_TX pin	Output	PC10 pin: USART3 in transmission mode
USARTx bootloaders	SysTick timer	Enabled	Used to automatically detect the serial baud rate from the host for USARTx bootloaders.
I2C1 bootloader	I2C1	Enabled	The I2C1 configuration is: I2C speed: up to 1 MHz, 7-bit address, slave mode, analog filter ON. Slave 7-bit address: 0b1001010x (where x = 0 for write and x = 1 for read)
	I2C1_SCL pin	Input/Output	PB6 pin: clock line is used in open-drain mode.
	I2C1_SDA pin	Input/Output	PB7 pin: data line is used in open-drain mode.
I2C2 bootloader	I2C2	Enabled	The I2C2 configuration is: I2C speed: up to 1 MHz, 7-bit address, slave mode, analog filter ON. Slave 7-bit address: 0b1001010x (where x = 0 for write and x = 1 for read)
	I2C2_SCL pin	Input/Output	PB10 pin: clock line is used in open-drain mode.
	I2C2_SDA pin	Input/Output	PB11 pin: data line is used in open-drain mode.
I2C3 bootloader	I2C3	Enabled	The I2C3 configuration is: I2C speed: up to 1 MHz, 7-bit address, slave mode, analog filter ON. Slave 7-bit address: 0b1001010x (where x = 0 for write and x = 1 for read)
	I2C3_SCL pin	Input/Output	PC0 pin: clock line is used in open-drain mode.
	I2C3_SDA pin	Input/Output	PC1 pin: data line is used in open-drain mode.

Table 127. STM32L45xxx/46xxx configuration in system memory boot mode (continued)

Bootloader	Feature/Peripheral	State	Comment
SPI1 bootloader	SPI1	Enabled	The SPI1 configuration is: – Slave mode – Full Duplex – 8-bit MSB – Speed up to 8 MHz – Polarity: CPOL Low, CPHA Low, NSS hardware.
	SPI1_MOSI pin	Input	PA7 pin: Slave data Input line, used in push-pull, pull-down mode
	SPI1_MISO pin	Output	PA6 pin: Slave data output line, used in push-pull, pull-down mode
	SPI1_SCK pin	Input	PA5 pin: Slave clock line, used in push-pull, pull-down mode
	SPI1_NSS pin	Input	PA4 pin: slave chip select pin used in push-pull, pull-down mode. Note: This IO can be tied to GND if the SPI Master does not use it.
SPI2 bootloader	SPI2	Enabled	The SPI2 configuration is: – Slave mode – Full Duplex – 8-bit MSB – Speed up to 8 MHz – Polarity: CPOL Low, CPHA Low, NSS hardware.
	SPI2_MOSI pin	Input	PB15 pin: Slave data Input line, used in push-pull, pull-down mode
	SPI2_MISO pin	Output	PB14 pin: Slave data output line, used in push-pull, pull-down mode
	SPI2_SCK pin	Input	PB13 pin: Slave clock line, used in push-pull, pull-down mode
	SPI2_NSS pin	Input	PB12 pin: slave chip select pin used in push-pull, pull-down mode. Note: This IO can be tied to GND if the SPI Master does not use it.
CAN1 bootloader	CAN1	Enabled	Once initialized the CAN1 configuration is: Baudrate 125 kbps, 11 -bit identifier.
	CAN1_RX pin	Input	PB8 pin: CAN1 in reception mode
	CAN1_TX pin	Output	PB9 pin: CAN1 in transmission mode
	TIM16	Enabled	This timer is used to determine the value of the HSE. Once the HSE frequency is determined, the system clock is configured to 60 MHz using PLL and HSE.

Table 127. STM32L45xxx/46xxx configuration in system memory boot mode (continued)

Bootloader	Feature/Peripheral	State	Comment
DFU bootloader	USB	Enabled	USB FS configured in forced device mode. USB FS interrupt vector is enabled and used for USB DFU communications. Note: VDDUSB IO must be connected to 3.3V as USB peripheral is used by the bootloader.
	USB_DM pin	Input/Output	PA11: USB DM line.
	USB_DP pin		PA12: USB DP line No external pull-up resistor is required

Note: If VDDUSB pin is not connected to VDD, then SPI Flash memory write operations may be corrupted due to voltage issue. For more details, please refer to product's datasheet and errata sheet.

59.2 Bootloader selection

The figures below show the bootloader selection mechanism.

Figure 76. Dual bank boot Implementation for STM32L45xxx/46xxx bootloader V9.x

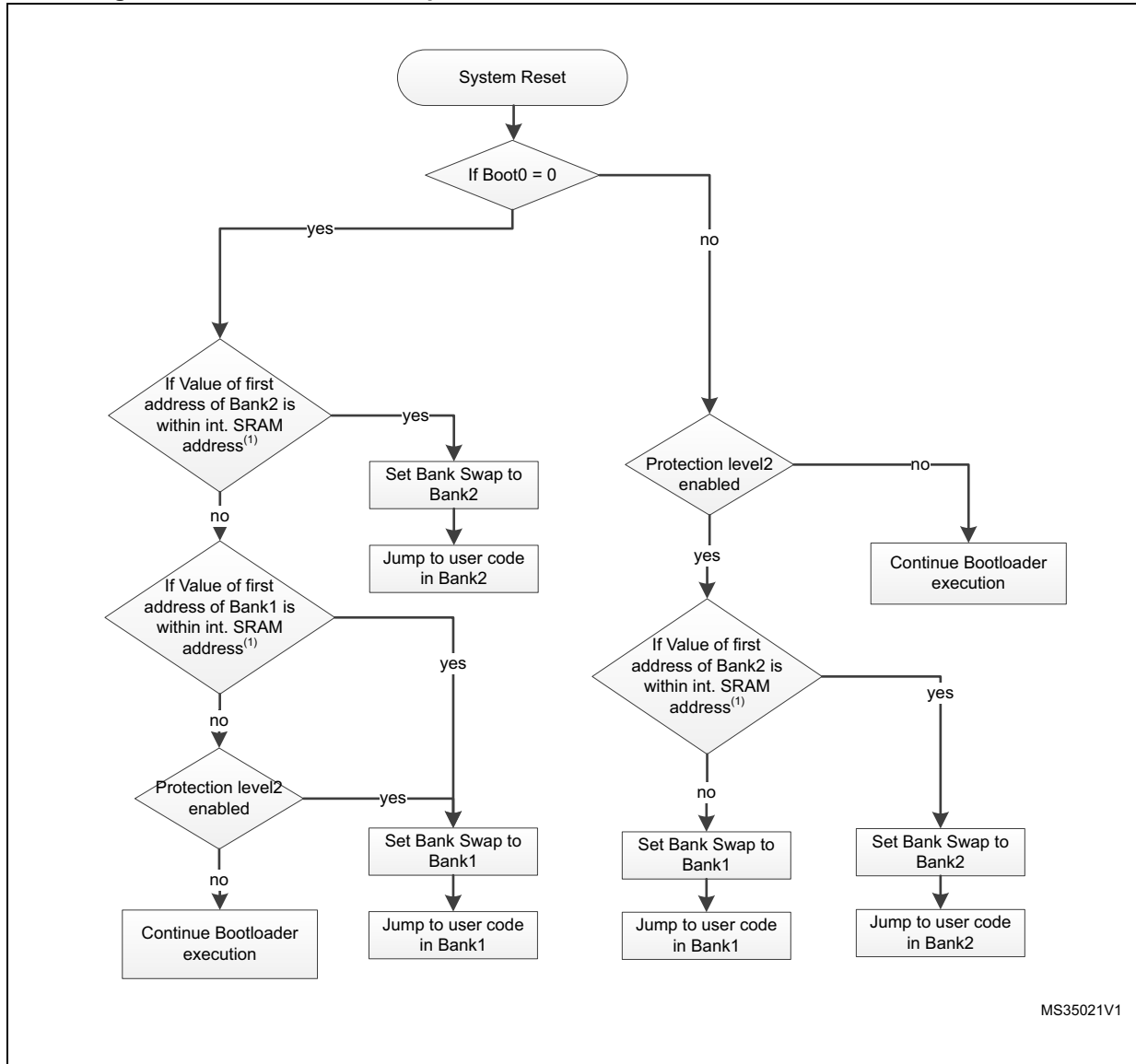
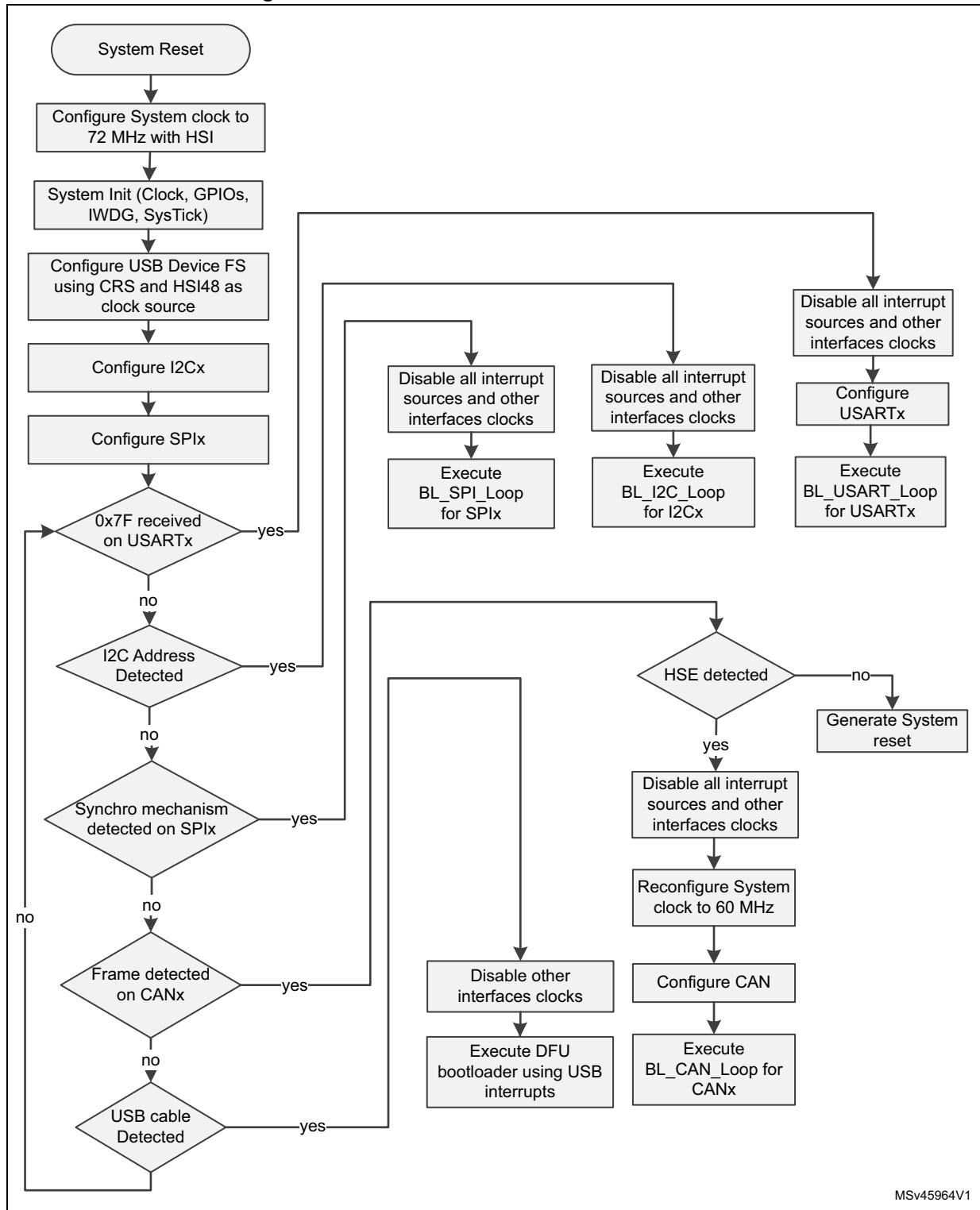

Figure 77.Bootloader V9.x selection for STM32L45xxx/46xxx



MSv45964V1

59.3 Bootloader version

Table 128 lists the STM32L45xxx/46xxx devices bootloader versions.

Table 128. STM32L45xxx/46xxx bootloader versions

Bootloader version number	Description	Known limitations
V9.2	Initial bootloader version	<ul style="list-style-type: none"> – PcROP option bytes cannot be written as Bootloader uses Byte access while PcROP must be accessed using Half-Word access. Workaround: load a code snippet in SRAM using Bootloader interface then jump to it, and that code would write PcROP value. – SPI write operation fail limitation: <ul style="list-style-type: none"> a. During Bootloader SPI write Flash memory operation, some random 64-bits (2 double-words) may be left blank at 0xFF. Root cause: <ul style="list-style-type: none"> a. Bootloader uses 64-bits cast write operation which is interrupted by SPI DMA and it leads to double access on same Flash memory address and the 64-bits are not written Workarounds: <ul style="list-style-type: none"> a. WA1: add a delay between sending write command and its ACK request. Its duration must be the duration of the 256-Bytes Flash memory write time. b. WA2: read back after write and in case of error start write again. c. WA3: Patch in RAM to write in Flash memory that implements write memory without 64-bits cast. WA1 and WA3 are more efficient than WA2 in terms of total programming time How critical is the limitation: <ul style="list-style-type: none"> a. The limitation leads to a modification in customer SPI host software by adding 3-4 ms delay to each write operation. b. The delay is not waste because it is anyway the Flash memory write period of time that host has to wait anyway (so instead of waiting by sending ACK requests, host will wait by delay). c. Limitation has been seen only on SPI and cannot impact USART/I2C/CAN.

60 STM32L47xxx/48xxx devices bootloader

Two bootloader versions are available on STM32L47xxx/48xxx:

- V10.x supporting USART, I2C and DFU (USB FS Device).
This version is embedded in STM32L47xxx/48xxx rev. 2 and rev. 3 devices.
- V9.x supporting USART, I2C, SPI, CAN and DFU (USB FS Device).
This version is embedded in STM32L47xxx/48xxx rev. 4 devices.

60.1 Bootloader V10.x

60.1.1 Bootloader configuration

The STM32L47xxx/48xxx bootloader is activated by applying Pattern 7 (described in [Table 2: Bootloader activation patterns](#)). The following table shows the hardware resources used by this bootloader.

Table 129. STM32L47xxx/48xxx configuration in system memory boot mode

Bootloader	Feature/Peripheral	State	Comment
Common to all bootloaders	RCC	HSI enabled	The HSI is used at startup as clock source for system clock configured to 24 MHz and for USART and I2C bootloader operation.
		HSE enabled	The HSE is used only when the USB interface is selected and the LSE is not present. The HSE must have one of the following values [24,20,18,16,12,9,8,6,4] MHz.
		LSE enabled	The LSE is used to trim the MSI which is configured to 48 MHz as USB clock source. The LSE must be equal to 32,768 kHz. If the LSE is not detected, the HSE is used instead if USB is connected.
		MSI enabled	The MSI is configured to 48 MHz and is used as USB clock source. The MSI is used only if LSE is detected, otherwise, HSE is used if USB is connected.
		-	The Clock Security System (CSS) interrupt is enabled when LSE or HSE is enabled. Any failure (or removal) of the external clock generates system reset.
	RAM	-	12 Kbyte starting from address 0x20000000 are used by the bootloader firmware
	System memory	-	28 Kbyte starting from address 0x1FFF0000, contain the bootloader firmware
	IWDG	-	The independent watchdog (IWDG) prescaler is configured to its maximum value. It is periodically refreshed to prevent watchdog reset (in case the hardware IWDG option was previously enabled by the user).
	Power	-	The DFU cannot be used to communicate with bootloader if the voltage scaling range 2 is selected. Bootloader firmware does not configure voltage scaling range value in PWR_CR1 register.

Table 129. STM32L47xxx/48xxx configuration in system memory boot mode (continued)

Bootloader	Feature/Peripheral	State	Comment
USART1 bootloader	USART1	Enabled	Once initialized the USART1 configuration is: 8-bit, even parity and 1 Stop bit
	USART1_RX pin	Input	PA10 pin: USART1 in reception mode
	USART1_TX pin	Output	PA9 pin: USART1 in transmission mode
USART2 bootloader	USART2	Enabled	Once initialized the USART2 configuration is: 8-bit, even parity and 1 Stop bit
	USART2_RX pin	Input	PA3 pin: USART2 in reception mode
	USART2_TX pin	Output	PA2 pin: USART2 in transmission mode
USART3 bootloader	USART3	Enabled	Once initialized the USART3 configuration is: 8-bit, even parity and 1 Stop bit
	USART3_RX pin	Input	PC11 pin: USART3 in reception mode
	USART3_TX pin	Output	PC10 pin: USART3 in transmission mode
USARTx bootloaders	SysTick timer	Enabled	Used to automatically detect the serial baud rate from the host for USARTx bootloaders.
I2C1 bootloader	I2C1	Enabled	The I2C1 configuration is: I2C speed: up to 400 kHz, 7-bit address, slave mode, analog filter ON. Slave 7-bit address: 0b1000011x (where x = 0 for write and x = 1 for read)
	I2C1_SCL pin	Input/Output	PB6 pin: clock line is used in open-drain mode.
	I2C1_SDA pin	Input/Output	PB7 pin: data line is used in open-drain mode.
I2C2 bootloader	I2C2	Enabled	The I2C2 configuration is: I2C speed: up to 400 kHz, 7-bit address, slave mode, analog filter ON. Slave 7-bit address: 0b1000011x (where x = 0 for write and x = 1 for read)
	I2C2_SCL pin	Input/Output	PB10 pin: clock line is used in open-drain mode.
	I2C2_SDA pin	Input/Output	PB11 pin: data line is used in open-drain mode.
I2C3 bootloader	I2C3	Enabled	The I2C3 configuration is: I2C speed: up to 400 kHz, 7-bit address, slave mode, analog filter ON. Slave 7-bit address is 0b1000011x (where x = 0 for write and x = 1 for read)
	I2C3_SCL pin	Input/Output	PC0 pin: clock line is used in open-drain mode.
	I2C3_SDA pin	Input/Output	PC1 pin: data line is used in open-drain mode.
DFU bootloader	USB	Enabled	USB OTG FS configured in forced device mode
	USB_DM pin	Input/Output	PA11: USB DM line.
	USB_DP pin		PA12: USB DP line No external pull-up resistor is required
	TIM17	Enabled	This timer is used to determine the value of the HSE. Once the HSE frequency is determined, the system clock is configured to 24 MHz using PLL and HSE.

For USARTx and I2Cx bootloaders no external clock is required.

USB bootloader (DFU) requires either an LSE (low-speed external clock) or a HSE (high-speed external clock):

- In case, the LSE is present regardless the HSE presence, the MSI is configured and trimmed by the LSE to provide an accurate clock equal to 48 MHz which is the clock source of the USB. The system clock is kept clocked to 24 MHz by the HSI.
- In case, the HSE is present, the system clock and USB clock is configured respectively to 24 MHz and 48 MHz with HSE as clock source.

60.1.2 Bootloader selection

Figure 78 and Figure 79 show the bootloader selection mechanism.

Figure 78. Dual bank boot implementation for STM32L47xxx/48xxx bootloader V10.x

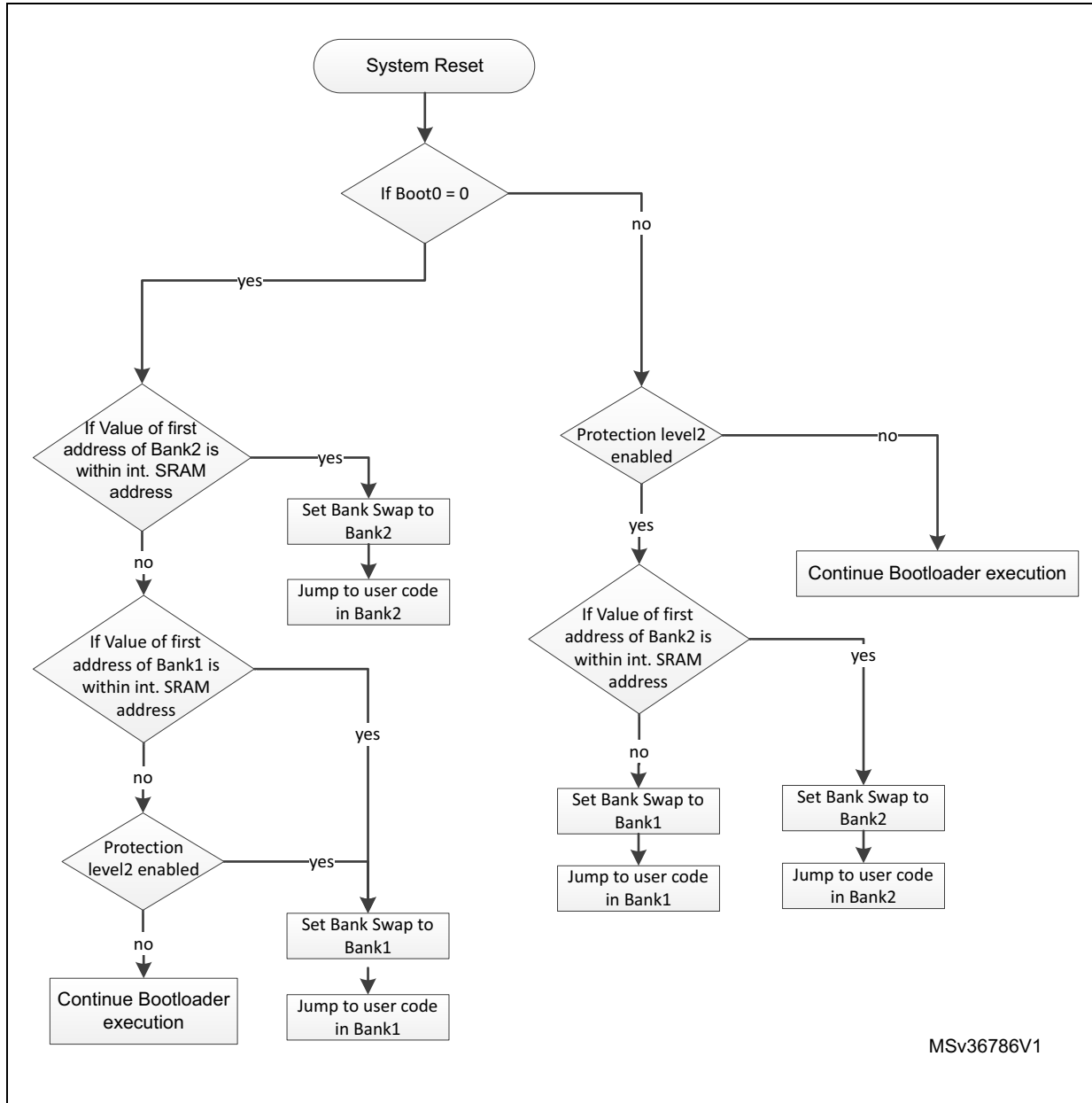
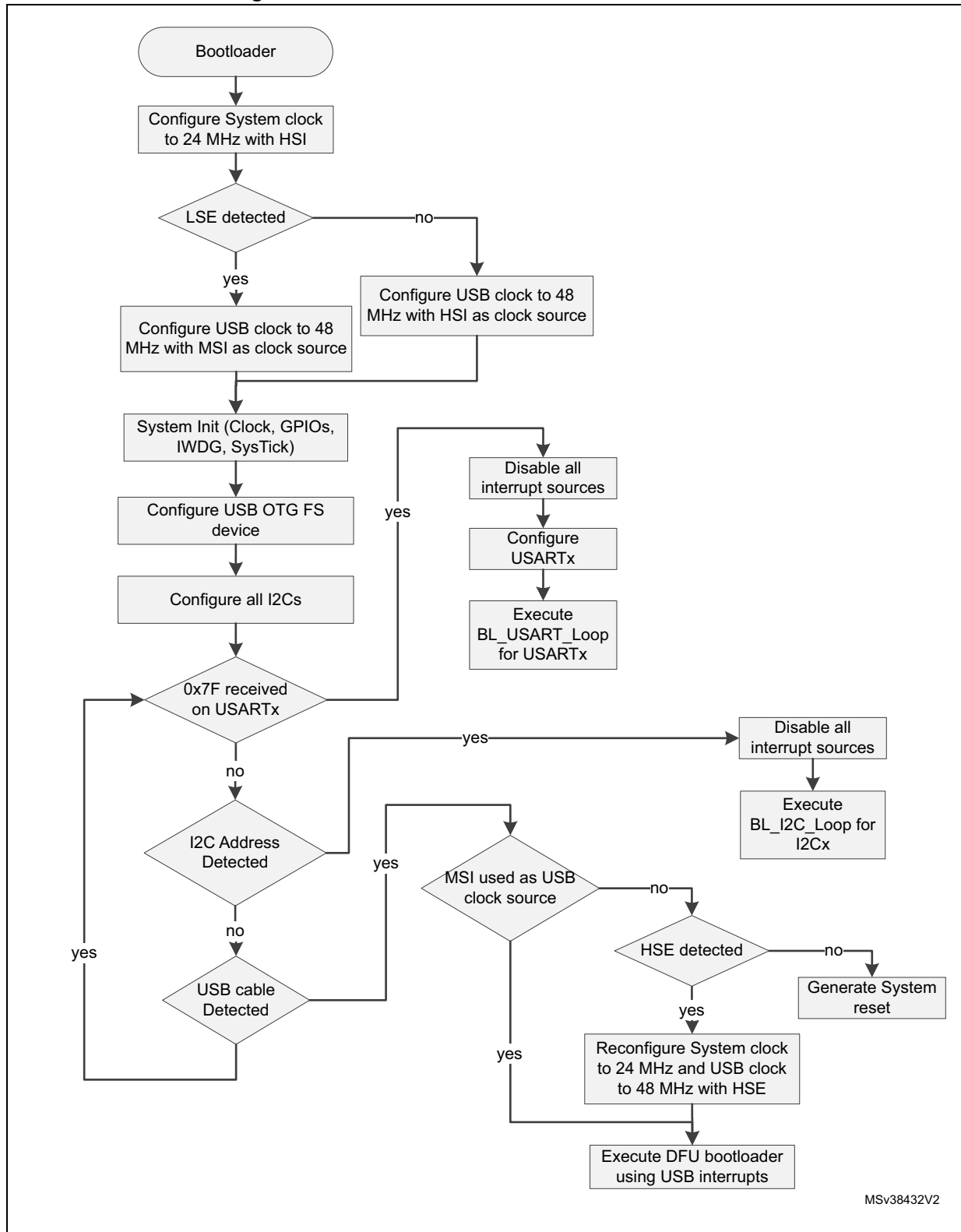

Figure 79.Bootloader V10.x selection for STM32L47xxx/48xxx



MSv38432V2

60.1.3 Bootloader version

The following table lists the STM32L47xxx/48xxx devices bootloader V10.x versions:

Table 130. STM32L47xxx/48xxx bootloader V10.x versions

Bootloader version number	Description	Known limitations
V10.1	Initial bootloader version	For memory write operations using DFU interface: If the buffer size is larger than 256 bytes and not multiple of 8 bytes, the write memory operation result is corrupted. Workaround: if the file size is larger than 256 bytes, add byte padding to align it on 8-bytes multiple size. Write in SRAM is corrupted.
V10.2	Fix write in SRAM issue	For memory write operations using DFU interface: If the buffer size is larger than 256 bytes and not multiple of 8 bytes, the write memory operation result is corrupted. Workaround: if the file size is larger than 256 bytes, add byte padding to align it on 8-bytes multiple size.
V10.3	Add support of MSI as USB clock source (MSI is trimmed by LSE). Update dual bank boot feature to support the case when user stack is mapped in SRAM2.	<ul style="list-style-type: none"> – For memory write operations using DFU interface: If the buffer size is larger than 256 bytes and not multiple of 8 bytes, the write memory operation result is corrupted. Workaround: if the file size is larger than 256 bytes, add byte padding to align it on 8-bytes multiple size. – PcROP option bytes cannot be written as Bootloader uses Byte access while PcROP must be accessed using Half-Word access. Workaround: load a code snippet in SRAM using Bootloader interface then jump to it, and that code would write PcROP value.

60.2 Bootloader V9.x

60.2.1 Bootloader configuration

The STM32L47xxx/48xxx bootloader is activated by applying Pattern 7 (described in [Table 2: Bootloader activation patterns](#)). The following table shows the hardware resources used by this bootloader.

Table 131. STM32L47xxx/48xxx configuration in system memory boot mode

Bootloader	Feature/Peripheral	State	Comment
Common to all bootloaders	RCC	HSI enabled	The HSI is used at startup as clock source for system clock configured to 72 MHz and for USART and I2C bootloader operation.
		HSE enabled	The HSE is used only when the USB interface is selected and the LSE is not present. The HSE must have one of the following values [24,20,18,16,12,8,6,4] MHz. System is clocked at 72 MHz if USB is used or 60 MHz if CAN is used.
		LSE enabled	The LSE is used to trim the MSI which is configured to 48 MHz as USB clock source. The LSE must be equal to 32,768 kHz. If the LSE is not detected, the HSE is used instead if USB is connected.
		MSI enabled	The MSI is configured to 48 MHz and is used as USB clock source. The MSI is used only if LSE is detected, otherwise, HSE is used if USB is connected.
		CSS	The Clock Security System (CSS) interrupt is enabled when LSE or HSE is enabled. Any failure (or removal) of the external clock generates system reset.
	RAM	-	13 Kbyte starting from address 0x20000000 are used by the bootloader firmware
	System memory	-	28 Kbyte starting from address 0x1FFF0000, contain the bootloader firmware
	IWDG	-	The independent watchdog (IWDG) prescaler is configured to its maximum value. It is periodically refreshed to prevent watchdog reset (in case the hardware IWDG option was previously enabled by the user).
	Power	-	The DFU cannot be used to communicate with bootloader if the voltage scaling range 2 is selected. Bootloader firmware does not configure voltage scaling range value in PWR_CR1 register.
USART1 bootloader	USART1	Enabled	Once initialized the USART1 configuration is: 8-bit, even parity and 1 Stop bit
	USART1_RX pin	Input	PA10 pin: USART2 in reception mode
	USART1_TX pin	Output	PA9 pin: USART2 in transmission mode

Table 131. STM32L47xxx/48xxx configuration in system memory boot mode (continued)

Bootloader	Feature/Peripheral	State	Comment
USART2 bootloader	USART2	Enabled	Once initialized the USART2 configuration is: 8-bit, even parity and 1 Stop bit
	USART2_RX pin	Input	PA3 pin: USART2 in reception mode
	USART2_TX pin	Output	PA2 pin: USART2 in transmission mode
USART3 bootloader	USART3	Enabled	Once initialized the USART3 configuration is: 8-bit, even parity and 1 Stop bit
	USART3_RX pin	Input	PC11 pin: USART3 in reception mode
	USART3_TX pin	Output	PC10 pin: USART3 in transmission mode
USARTx bootloaders	SysTick timer	Enabled	Used to automatically detect the serial baud rate from the host for USARTx bootloaders.
I2C1 bootloader	I2C1	Enabled	The I2C1 configuration is: I2C speed: up to 400 kHz, 7-bit address, slave mode, analog filter ON. Slave 7-bit address: 0b1000011x (where x = 0 for write and x = 1 for read)
	I2C1_SCL pin	Input/Output	PB6 pin: clock line is used in open-drain mode.
	I2C1_SDA pin	Input/Output	PB7 pin: data line is used in open-drain mode.
I2C2 bootloader	I2C2	Enabled	The I2C2 configuration is: I2C speed: up to 400 kHz, 7-bit address, slave mode, analog filter ON. Slave 7-bit address: 0b1000011x (where x = 0 for write and x = 1 for read)
	I2C2_SCL pin	Input/Output	PB10 pin: clock line is used in open-drain mode.
	I2C2_SDA pin	Input/Output	PB11 pin: data line is used in open-drain mode.
I2C3 bootloader	I2C3	Enabled	The I2C3 configuration is: I2C speed: up to 400 kHz, 7-bit address, slave mode, analog filter ON. Slave 7-bit address: 0b1000011x (where x = 0 for write and x = 1 for read)
	I2C3_SCL pin	Input/Output	PC0 pin: clock line is used in open-drain mode.
	I2C3_SDA pin	Input/Output	PC1 pin: data line is used in open-drain mode.
SPI1 bootloader	SPI1	Enabled	The SPI1 configuration is: Slave mode, Full Duplex, 8-bit MSB, Speed up to 8 MHz, Polarity: CPOL Low, CPHA Low, NSS hardware.
	SPI1_MOSI pin	Input	PA7 pin: Slave data Input line, used in push-pull, pull-down mode
	SPI1_MISO pin	Output	PA6 pin: Slave data output line, used in push-pull, pull-down mode
	SPI1_SCK pin	Input	PA5 pin: Slave clock line, used in push-pull, pull-down mode
	SPI1_NSS pin	Input	PA4 pin: slave chip select pin used in push-pull, pull-down mode.

Table 131. STM32L47xxx/48xxx configuration in system memory boot mode (continued)

Bootloader	Feature/Peripheral	State	Comment
SPI2 bootloader	SPI2	Enabled	The SPI2 configuration is: Slave mode, Full Duplex, 8-bit MSB, Speed up to 8 MHz, Polarity: CPOL Low, CPHA Low, NSS hardware
	SPI2_MOSI pin	Input	PB15 pin: Slave data Input line, used in push-pull, pull-down mode
	SPI2_MISO pin	Output	PB14 pin: Slave data output line, used in push-pull, pull-down mode
	SPI2_SCK pin	Input	PB13 pin: Slave clock line, used in push-pull, pull-down mode
	SPI2_NSS pin	Input	PB12 pin: slave chip select pin used in push-pull, pull-down mode.
CAN1 bootloader	CAN1	Enabled	Once initialized the CAN1 configuration is: Baudrate 125 kbps, 11-bit identifier.
	CAN1_RX pin	Input	PB8 pin: CAN1 in reception mode
	CAN1_TX pin	Output	PB9 pin: CAN1 in transmission mode
DFU bootloader	USB	Enabled	USB FS configured in forced device mode. USB FS interrupt vector is enabled and used for USB DFU communications. Note: VDDUSB IO must be connected to 3.3 V as USB peripheral is used by the bootloader.
	USB_DM pin	Input/Output	PA11 pin: USB FS DM line
	USB_DP pin		PA12 pin: USB FS DP line. No external pull-up resistor is required.

In case, the HSE is present, the system clock and USB clock is configured respectively to 72 MHz and 48 MHz with PLL (clocked by HSE) as a clock source.

Note: If VDDUSB pin is not connected to VDD, then SPI Flash memory write operations may be corrupted due to voltage issue. For more details, please refer to product's datasheet and errata sheet.

60.2.2 Bootloader selection

Figure 80 and Figure 81 show the bootloader selection mechanism.

Figure 80. Dual bank boot implementation for STM32L47xxx/48xxx bootloader V9.x

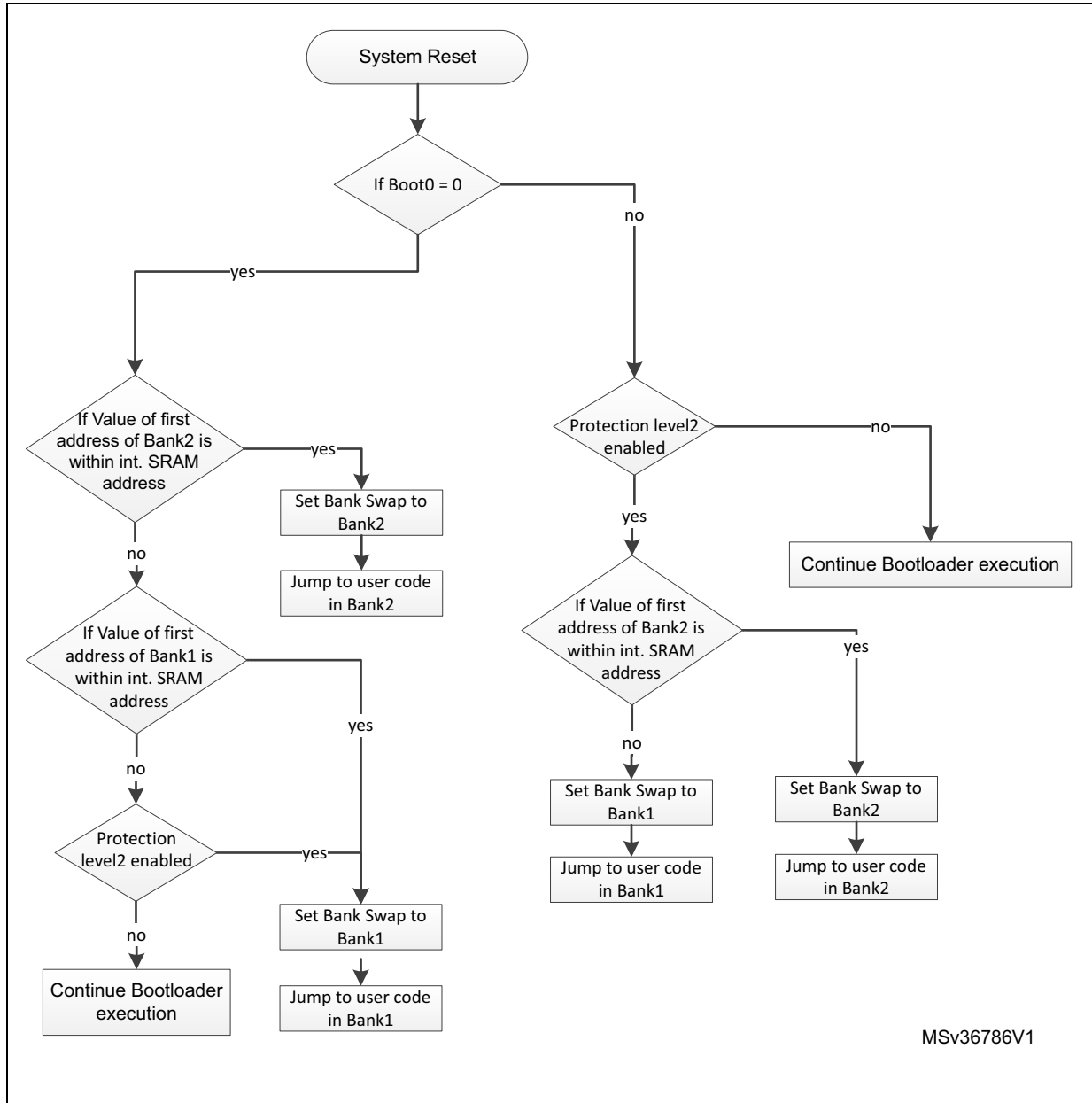
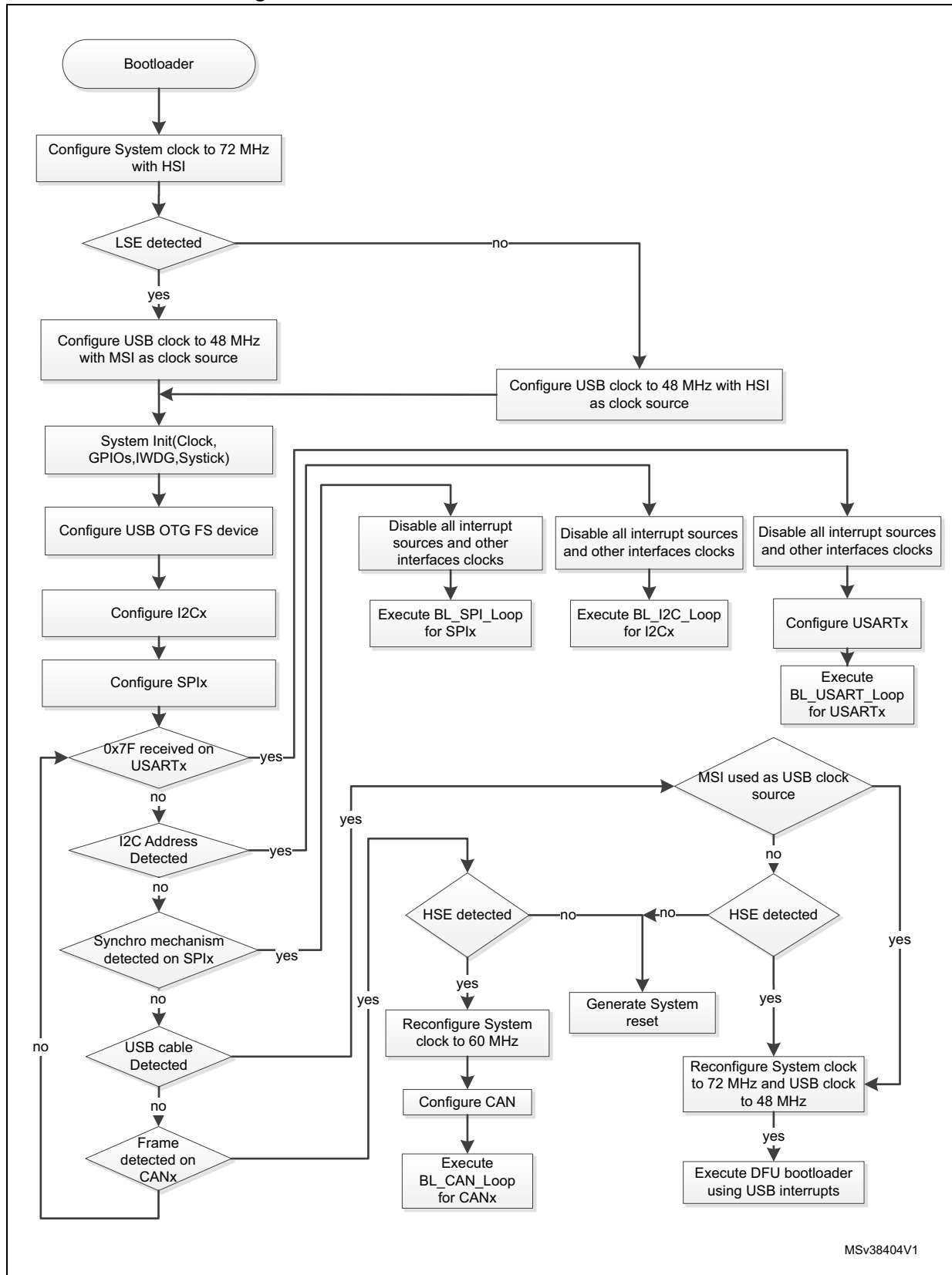

Figure 81.Bootloader V9.x selection for STM32L47xxx/48xxx



MSv38404V1

60.2.3 Bootloader version

The following table lists the STM32L47xxx/48xxx devices bootloader V9.x versions:

Table 132. STM32L47xxx/48xxx bootloader V9.x versions

Bootloader version number	Description	Known limitations
V9.0	Initial bootloader version	For memory write operations using DFU interface: If the buffer size is larger than 256 bytes and not multiple of 8 bytes, the write memory operation result is corrupted. Workaround: if the file size is larger than 256 bytes, add byte padding to align it on 8-bytes multiple size. Write in SRAM is corrupted
V9.1	Deprecated version (not used)	None
V9.2	Fix write in SRAM issue	<ul style="list-style-type: none"> – For memory write operations using DFU interface: If the buffer size is larger than 256 bytes and not multiple of 8 bytes, the write memory operation result is corrupted. Workaround: if the file size is larger than 256 bytes, add byte padding to align it on 8-bytes multiple size. – PcROP option bytes cannot be written as Bootloader uses Byte access while PcROP must be accessed using Half-Word access. Workaround: load a code snippet in SRAM using Bootloader interface then jump to it, and that code would write PcROP value.

61 STM32L496xx/4A6xx devices bootloader

61.1 Bootloader configuration

The STM32L496xx/4A6xx bootloader is activated by applying Pattern 6 (described in [Table 2: Bootloader activation patterns](#)). [Table 133](#) shows the hardware resources used by this bootloader.

Table 133. STM32L496xx/4A6xx configuration in system memory boot mode

Bootloader	Feature/Peripheral	State	Comment
Common to all bootloaders	RCC	HSI enabled	The HSI is used at startup as clock source for system clock configured to 72 MHz and for USART, I2C and SPI bootloader operation.
		-	The clock recovery system (CRS) is enabled for the DFU bootloader to allow USB to be clocked by HSI 48 MHz.
		HSE enabled	The HSE is used only when the CAN interface is selected . The HSE must have one of the following value [24,20,18,16,12,9,8,6,4] MHz.
		-	The Clock Security System (CSS) interrupt is enabled when HSE is enabled. Any failure (or removal) of the external clock generates system reset
	RAM	-	12 Kbyte starting from address 0x20000000 are used by the bootloader firmware
	System memory	-	28 Kbyte starting from address 0x1FFF0000, contain the bootloader firmware
	IWDG	-	The independent watchdog (IWDG) prescaler is configured to its maximum value. It is periodically refreshed to prevent watchdog reset (in case the hardware IWDG option was previously enabled by the user).
	Power	-	The DFU cannot be used to communicate with bootloader if the voltage scaling range 2 is selected. Bootloader firmware does not configure voltage scaling range value in PWR_CR1 register.
USART1 bootloader	USART1	Enabled	Once initialized the USART1 configuration is: 8-bit, even parity and 1 Stop bit
	USART1_RX pin	Input	PA10 pin: USART1 in reception mode
	USART1_TX pin	Output	PA9 pin: USART1 in transmission mode

Table 133. STM32L496xx/4A6xx configuration in system memory boot mode (continued)

Bootloader	Feature/Peripheral	State	Comment
USART2 bootloader	USART2	Enabled	Once initialized the USART2 configuration is: 8-bit, even parity and 1 Stop bit
	USART2_RX pin	Input	PA3 pin: USART2 in reception mode
	USART2_TX pin	Output	PA2 pin: USART2 in transmission mode
USART3 bootloader	USART3	Enabled	Once initialized the USART3 configuration is: 8-bit, even parity and 1 Stop bit
	USART3_RX pin	Input	PC11 pin: USART3 in reception mode
	USART3_TX pin	Output	PC10 pin: USART3 in transmission mode
USARTx bootloaders	SysTick timer	Enabled	Used to automatically detect the serial baud rate from the host for USARTx bootloaders.
I2C1 bootloader	I2C1	Enabled	The I2C1 configuration is: I2C speed: up to 1 MHz, 7-bit address, slave mode, analog filter ON. Slave 7-bit address: 0b1001100x (where x = 0 for write and x = 1 for read)
	I2C1_SCL pin	Input/Output	PB6 pin: clock line is used in open-drain mode.
	I2C1_SDA pin	Input/Output	PB7 pin: data line is used in open-drain mode.
I2C2 bootloader	I2C2	Enabled	The I2C2 configuration is: I2C speed: up to 1 MHz, 7-bit address, slave mode, analog filter ON. Slave 7-bit address: 0b1001100x (where x = 0 for write and x = 1 for read)
	I2C2_SCL pin	Input/Output	PB10 pin: clock line is used in open-drain mode.
	I2C2_SDA pin	Input/Output	PB11 pin: data line is used in open-drain mode.
I2C3 bootloader	I2C3	Enabled	The I2C3 configuration is: I2C speed: up to 1 MHz, 7-bit address, slave mode, analog filter ON. Slave 7-bit address: 0b1001100x (where x = 0 for write and x = 1 for read)
	I2C3_SCL pin	Input/Output	PC0 pin: clock line is used in open-drain mode.
	I2C3_SDA pin	Input/Output	PC1 pin: data line is used in open-drain mode.

Table 133. STM32L496xx/4A6xx configuration in system memory boot mode (continued)

Bootloader	Feature/Peripheral	State	Comment
SPI1 bootloader	SPI1	Enabled	The SPI1 configuration is: – Slave mode – Full Duplex – 8-bit MSB – Speed up to 8 MHz – Polarity: CPOL Low, CPHA Low, NSS hardware.
	SPI1_MOSI pin	Input	PA7 pin: Slave data Input line, used in push-pull, pull-down mode
	SPI1_MISO pin	Output	PA6 pin: Slave data output line, used in push-pull, pull-down mode
	SPI1_SCK pin	Input	PA5 pin: Slave clock line, used in push-pull, pull-down mode
	SPI1_NSS pin	Input	PA4 pin: slave chip select pin used in push-pull, pull-down mode. Note: This IO can be tied to GND if the SPI Master does not use it.
SPI2 bootloader	SPI2	Enabled	The SPI2 configuration is: – Slave mode – Full Duplex – 8-bit MSB – Speed up to 8 MHz – Polarity: CPOL Low, CPHA Low, NSS hardware.
	SPI2_MOSI pin	Input	PB15 pin: Slave data Input line, used in push-pull, pull-down mode
	SPI2_MISO pin	Output	PB14 pin: Slave data output line, used in push-pull, pull-down mode
	SPI2_SCK pin	Input	PB13 pin: Slave clock line, used in push-pull, pull-down mode
	SPI2_NSS pin	Input	PB12 pin: slave chip select pin used in push-pull, pull-down mode. Note: This IO can be tied to GND if the SPI Master does not use it.
CAN1 bootloader	CAN1	Enabled	Once initialized the CAN1 configuration is: Baudrate 125 kbps, 11 -bit identifier.
	CAN1_RX pin	Input	PB8 pin: CAN1 in reception mode
	CAN1_TX pin	Output	PB9 pin: CAN1 in transmission mode
	TIM16	Enabled	This timer is used to determine the value of the HSE. Once the HSE frequency is determined, the system clock is configured to 60 MHz using PLL and HSE.

Table 133. STM32L496xx/4A6xx configuration in system memory boot mode (continued)

Bootloader	Feature/Peripheral	State	Comment
DFU bootloader	USB	Enabled	USB OTG FS configured in forced device mode. USB OTG FS interrupt vector is enabled and used for USB DFU communications. Note: VDDUSB IO must be connected to 3.3 V as USB peripheral is used by the bootloader.
	USB_DM pin	Input/Output	PA11: USB DM line.
	USB_DP pin		PA12: USB DP line No external pull-up resistor is required

Note: If VDDUSB pin is not connected to VDD, then SPI Flash memory write operations may be corrupted due to voltage issue. For more details, please refer to product's datasheet and errata sheet.

61.2 Bootloader selection

The figures below show the bootloader selection mechanism.

Figure 82. Dual bank boot Implementation for STM32L496xx/4A6xx bootloader V9.x

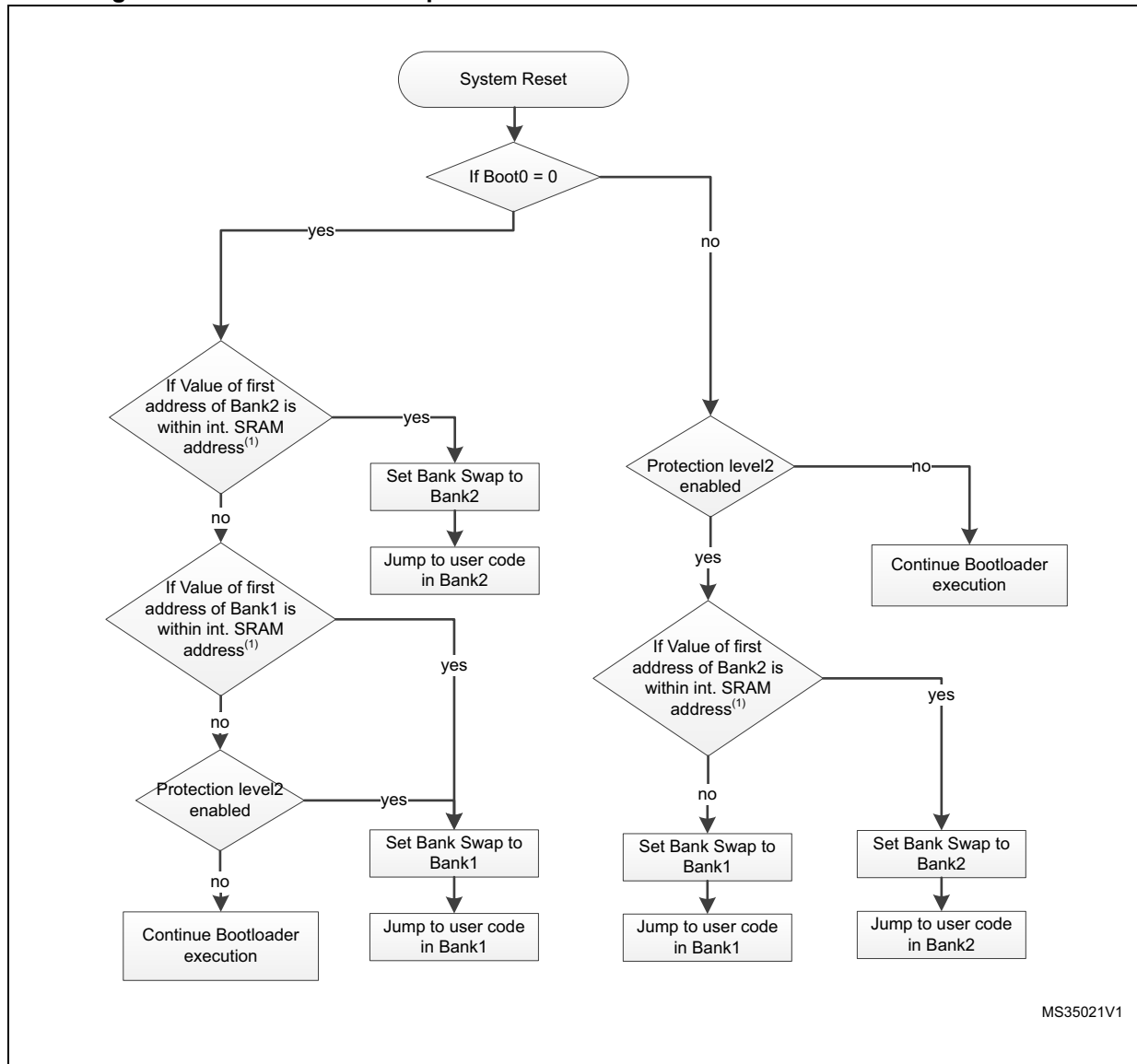
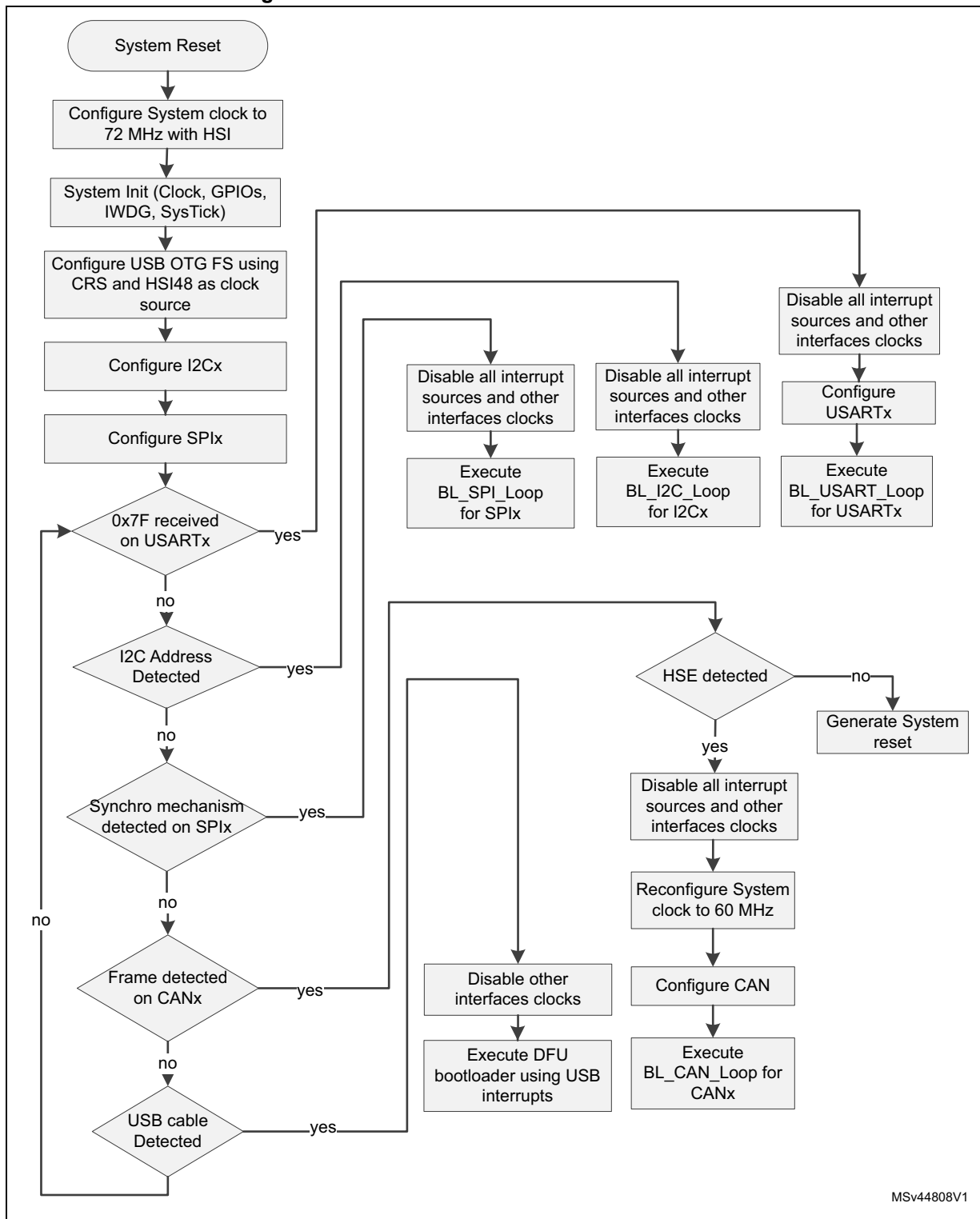

Figure 83.Bootloader V9.x selection for STM32L496xx/4A6xx



MSv44808V1

61.3 Bootloader version

Table 134 lists the STM32L496xx/4A6xx devices bootloader versions.

Table 134. STM32L496xx/4A6xx bootloader version

Bootloader version number	Description	Known limitations
V9.3	Initial bootloader version	<ul style="list-style-type: none"> - The Bank Erase command is aborted by the bootloader device, and the NACK (0x1F) is sent to the host. Workaround: Perform Bank erase operation through page erase using the Erase command (0x44). - SPI write operation fail <p>Limitation:</p> <ul style="list-style-type: none"> a. During Bootloader SPI write Flash memory operation, some random 64-bits (2 double-words) may be left blank at 0xFF. <p>Root cause:</p> <ul style="list-style-type: none"> a. Bootloader uses 64-bits cast write operation which is interrupted by SPI DMA and it leads to double access on same Flash memory address and the 64-bits are not written <p>Workarounds:</p> <ul style="list-style-type: none"> a. WA1: add a delay between sending write command and its ACK request. Its duration must be the duration of the 256-Bytes Flash memory write time. b. WA2: read back after write and in case of error start write again. c. WA3: Patch in RAM to write in Flash memory that implements write memory without 64-bits cast. <p>WA1 and WA3 are more efficient than WA2 in terms of total programming time</p> <p>How critical is the limitation:</p> <ul style="list-style-type: none"> a. The limitation leads to a modification in customer SPI host software by adding 3-4 ms delay to each write operation. b. The delay is not waste because it is anyway the Flash memory write period of time that host has to wait anyway (so instead of waiting by sending ACK requests, host will wait by delay). c. Limitation has been seen only on SPI and cannot impact USART/I2C/CAN. <ul style="list-style-type: none"> - PcROP option bytes cannot be written as Bootloader uses Byte access while PcROP must be accessed using Half-Word access. <p>Workaround: load a code snippet in SRAM using Bootloader interface then jump to it, and that code would write PcROP value.</p>

62 STM32L4P5xx/4Q5xx devices bootloader

62.1 Bootloader configuration

The STM32L4P5xx/4Q5xx bootloader is activated by applying Pattern 7 (described in [Table 2: Bootloader activation patterns](#)). [Table 137](#) shows the hardware resources used by this bootloader.

Table 135. STM32L4P5xx/4Q5xx configuration in system memory boot mode

Bootloader	Feature/Peripheral	State	Comment
Common to all bootloaders	RCC	HSI enabled	The HSI is used at startup as clock source for system clock configured to 60 MHz and for USART, I2C, SPI and USB bootloader operation.
		-	The clock recovery system (CRS) is enabled for the DFU bootloader to allow USB to be clocked by HSI 48 MHz.
		HSE enabled	The HSE is used only when the CAN interface is selected . The HSE must have one of the following value [24,20,18,16,12,9,8,6,4] MHz.
		-	The Clock Security System (CSS) interrupt is enabled when HSE is enabled. Any failure (or removal) of the external clock generates system reset
	RAM	-	16 Kbytes starting from address 0x20000000 are used by the bootloader firmware
	System memory	-	28 Kbytes starting from address 0x1FFF0000, contain the bootloader firmware
	IWDG	-	The independent watchdog (IWDG) prescaler is configured to its maximum value. It is periodically refreshed to prevent watchdog reset (in case the hardware IWDG option was previously enabled by the user).
	Power	-	The DFU cannot be used to communicate with bootloader if the voltage scaling range 2 is selected. Bootloader firmware does not configure voltage scaling range value in PWR_CR1 register.
USART1 bootloader	USART1	Enabled	Once initialized the USART1 configuration is: 8-bit, even parity and 1 Stop bit
	USART1_RX pin	Input	PA10 pin: USART1 in reception mode
	USART1_TX pin	Output	PA9 pin: USART1 in transmission mode

Table 135. STM32L4P5xx/4Q5xx configuration in system memory boot mode (continued)

Bootloader	Feature/Peripheral	State	Comment
USART2 bootloader	USART2	Enabled	Once initialized the USART2 configuration is: 8-bit, even parity and 1 Stop bit
	USART2_RX pin	Input	PA3 pin: USART2 in reception mode
	USART2_TX pin	Output	PA2 pin: USART2 in transmission mode
USART3 bootloader	USART3	Enabled	Once initialized the USART3 configuration is: 8-bit, even parity and 1 Stop bit
	USART3_RX pin	Input	PC11 pin: USART3 in reception mode
	USART3_TX pin	Output	PC10 pin: USART3 in transmission mode
I2C1 bootloader	I2C1	Enabled	The I2C1 configuration is: I2C speed: up to 1 MHz, 7-bit address, slave mode, analog filter ON. Slave 7-bit address: 0b1011011x (where x = 0 for write and x = 1 for read)
	I2C1_SCL pin	Input/Output	PB6 pin: clock line is used in open-drain mode.
	I2C1_SDA pin	Input/Output	PB7 pin: data line is used in open-drain mode.
I2C2 bootloader	I2C2	Enabled	The I2C2 configuration is: I2C speed: up to 1 MHz, 7-bit address, slave mode, analog filter ON. Slave 7-bit address: 0b1011011x (where x = 0 for write and x = 1 for read)
	I2C2_SCL pin	Input/Output	PB10 pin: clock line is used in open-drain mode.
	I2C2_SDA pin	Input/Output	PB11 pin: data line is used in open-drain mode.
I2C3 bootloader	I2C3	Enabled	The I2C3 configuration is: I2C speed: up to 1 MHz, 7-bit address, slave mode, analog filter ON. Slave 7-bit address: 0b1011011x (where x = 0 for write and x = 1 for read)
	I2C3_SCL pin	Input/Output	PC0 pin: clock line is used in open-drain mode.
	I2C3_SDA pin	Input/Output	PC1 pin: data line is used in open-drain mode.

Table 135. STM32L4P5xx/4Q5xx configuration in system memory boot mode (continued)

Bootloader	Feature/Peripheral	State	Comment
SPI1 bootloader	SPI1	Enabled	The SPI1 configuration is: <ul style="list-style-type: none"> – Slave mode – Full Duplex – 8-bit MSB – Speed up to 8 MHz – Polarity: CPOL Low, CPHA Low, NSS hardware.
	SPI1_MOSI pin	Input	PA7 pin: Slave data Input line, used in push-pull, pull-down mode
	SPI1_MISO pin	Output	PA6 pin: Slave data output line, used in push-pull, pull-down mode
	SPI1_SCK pin	Input	PA5 pin: Slave clock line, used in push-pull, pull-down mode
	SPI1_NSS pin	Input	PA4 pin: slave chip select pin used in push-pull, pull-down mode. Note: This IO can be tied to GND if the SPI Master does not use it.
SPI2 bootloader	SPI2	Enabled	The SPI2 configuration is: <ul style="list-style-type: none"> – Slave mode – Full Duplex – 8-bit MSB – Speed up to 8 MHz – Polarity: CPOL Low, CPHA Low, NSS hardware.
	SPI2_MOSI pin	Input	PB15 pin: Slave data Input line, used in push-pull, pull-down mode
	SPI2_MISO pin	Output	PB14 pin: Slave data output line, used in push-pull, pull-down mode
	SPI2_SCK pin	Input	PB13 pin: Slave clock line, used in push-pull, pull-down mode
	SPI2_NSS pin	Input	PB12 pin: slave chip select pin used in push-pull, pull-down mode. Note: This IO can be tied to GND if the SPI Master does not use it.
CAN1 bootloader	CAN1	Enabled	Once initialized the CAN1 configuration is: Baudrate 125 kbps, 11 -bit identifier.
	CAN1_RX pin	Input	PB8 pin: CAN1 in reception mode
	CAN1_TX pin	Output	PB9 pin: CAN1 in transmission mode

Table 135. STM32L4P5xx/4Q5xx configuration in system memory boot mode (continued)

Bootloader	Feature/Peripheral	State	Comment
DFU bootloader	USB	Enabled	USB FS configured in forced device mode. USB FS interrupt vector is enabled and used for USB DFU communications. Note: VDDUSB IO must be connected to 3.3 V as USB peripheral is used by the bootloader.
	USB_DM pin	Input/Output	PA11: USB DM line.
	USB_DP pin		PA12: USB DP line No external pull-up resistor is required

62.2 Bootloader selection

Figure 86 and Figure 87 show the bootloader selection mechanisms.

Figure 84. Dual bank boot implementation for STM32L4P5xx/4Q5xx bootloader V9.x

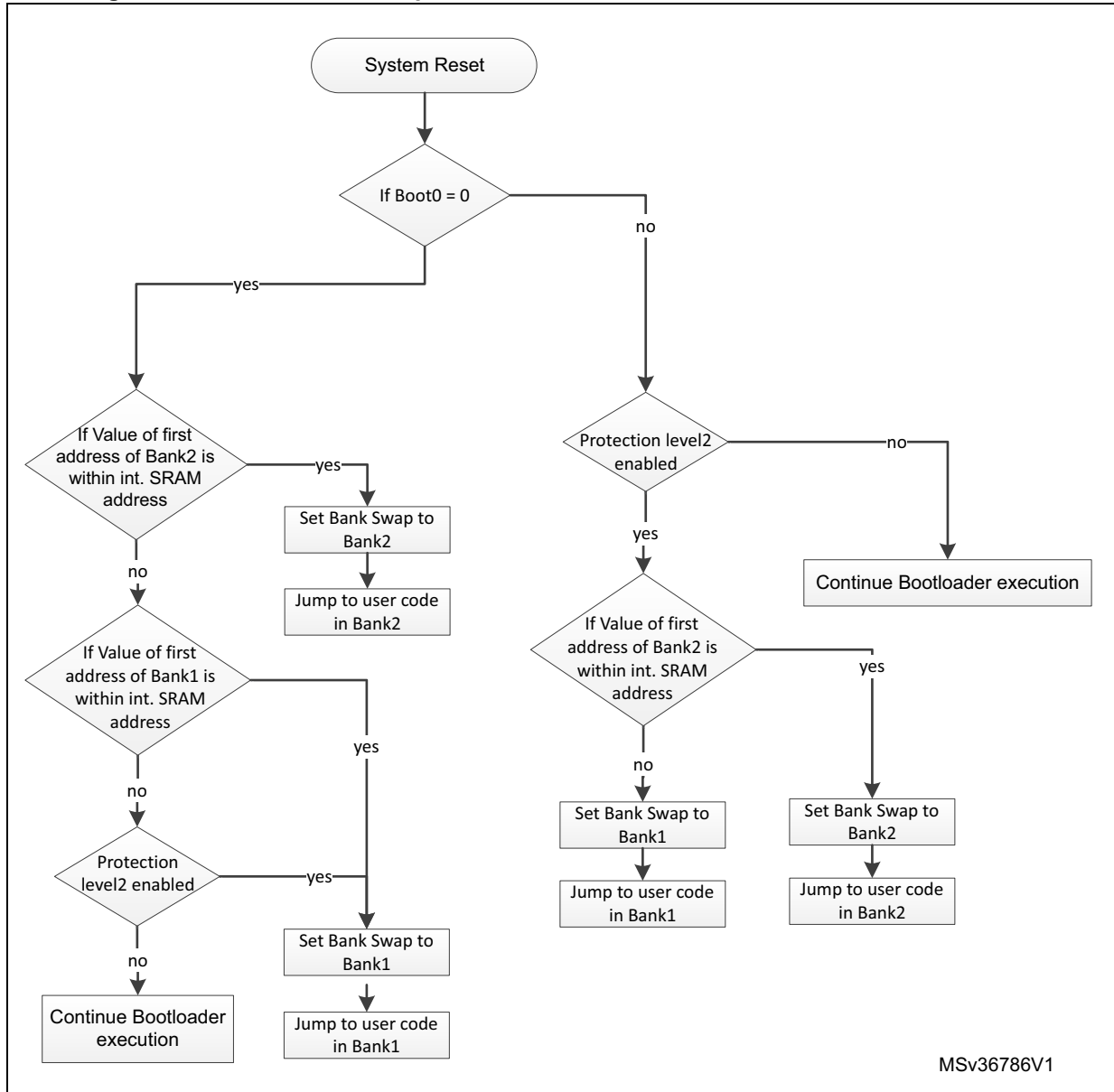
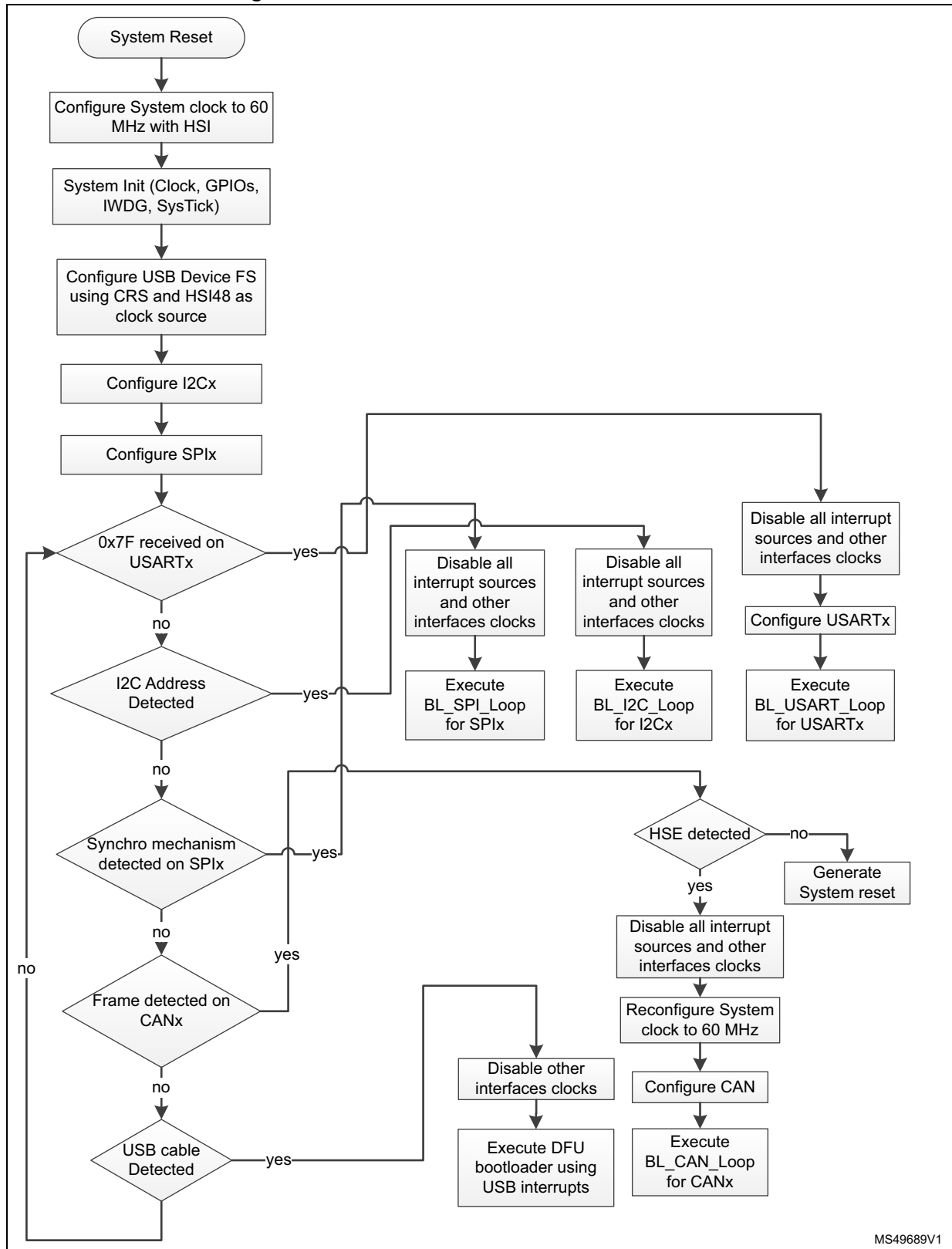

Figure 85.Bootloader V9.x selection for STM32L4P5xx/4Q5xx



MS49689V1

62.3 Bootloader version

[Table 136](#) lists the STM32L4P5xx/4Q5xx devices bootloader versions.

Table 136. STM32L4P5xx/4Q5xx bootloader versions

Bootloader version number	Description	Known limitations
V9.0	Initial bootloader version on cut 1.0 samples	<ul style="list-style-type: none">– PcROP option bytes cannot be written as bootloader uses byte access while PcROP must be accessed using half-word access. Workaround: load a code snippet in SRAM using bootloader interface then jump to it, and that code writes PcROP value.

63 STM32L4Rxxx/4Sxxx devices bootloader

63.1 Bootloader configuration

The STM32L4Rxx/4Sxx bootloader is activated by applying Pattern 6 (described in [Table 2: Bootloader activation patterns](#)). [Table 137](#) shows the hardware resources used by this bootloader.

Table 137. STM32L4Rxxx/4Sxxx configuration in system memory boot mode

Bootloader	Feature/Peripheral	State	Comment
Common to all bootloaders	RCC	HSI enabled	The HSI is used at startup as clock source for system clock configured to 60 MHz and for USART, I2C, SPI and USB bootloader operation.
		-	The clock recovery system (CRS) is enabled for the DFU bootloader to allow USB to be clocked by HSI 48 MHz.
		HSE enabled	The HSE is used only when the CAN interface is selected . The HSE must have one of the following values [24,20,18,16,12,9,8,6,4] MHz.
		-	The Clock Security System (CSS) interrupt is enabled when HSE is enabled. Any failure (or removal) of the external clock generates system reset
	RAM	-	12 Kbytes starting from address 0x20000000 are used by the bootloader firmware
	System memory	-	28672 bytes starting from address 0x1FFF0000, contain the bootloader firmware
	IWDG	-	The independent watchdog (IWDG) prescaler is configured to its maximum value. It is periodically refreshed to prevent watchdog reset (in case the hardware IWDG option was previously enabled by the user).
	Power	-	The DFU cannot be used to communicate with bootloader if the voltage scaling range 2 is selected. Bootloader firmware does not configure voltage scaling range value in PWR_CR1 register.
USART1 bootloader	USART1	Enabled	Once initialized the USART1 configuration is: 8-bit, even parity and 1 Stop bit
	USART1_RX pin	Input	PA10 pin: USART1 in reception mode
	USART1_TX pin	Output	PA9 pin: USART1 in transmission mode

Table 137. STM32L4Rxxx/4Sxxx configuration in system memory boot mode (continued)

Bootloader	Feature/Peripheral	State	Comment
USART2 bootloader	USART2	Enabled	Once initialized the USART2 configuration is: 8-bit, even parity and 1 Stop bit
	USART2_RX pin	Input	PA3 pin: USART2 in reception mode
	USART2_TX pin	Output	PA2 pin: USART2 in transmission mode
USART3 bootloader	USART3	Enabled	Once initialized the USART3 configuration is: 8-bit, even parity and 1 Stop bit
	USART3_RX pin	Input	PC11 pin: USART3 in reception mode
	USART3_TX pin	Output	PC10 pin: USART3 in transmission mode
USARTx bootloaders	SysTick timer	Enabled	Used to automatically detect the serial baud rate from the host for USARTx bootloaders.
I2C1 bootloader	I2C1	Enabled	The I2C1 configuration is: I2C speed: up to 1 MHz, 7-bit address, slave mode, analog filter ON. Slave 7-bit address: 0b1010000x (where x = 0 for write and x = 1 for read)
	I2C1_SCL pin	Input/Output	PB6 pin: clock line is used in open-drain mode.
	I2C1_SDA pin	Input/Output	PB7 pin: data line is used in open-drain mode.
I2C2 bootloader	I2C2	Enabled	The I2C2 configuration is: I2C speed: up to 1 MHz, 7-bit address, slave mode, analog filter ON. Slave 7-bit address: 0b1010000x (where x = 0 for write and x = 1 for read)
	I2C2_SCL pin	Input/Output	PB10 pin: clock line is used in open-drain mode.
	I2C2_SDA pin	Input/Output	PB11 pin: data line is used in open-drain mode.
I2C3 bootloader	I2C3	Enabled	The I2C3 configuration is: I2C speed: up to 1 MHz, 7-bit address, slave mode, analog filter ON. Slave 7-bit address: 0b1010000x (where x = 0 for write and x = 1 for read)
	I2C3_SCL pin	Input/Output	PC0 pin: clock line is used in open-drain mode.
	I2C3_SDA pin	Input/Output	PC1 pin: data line is used in open-drain mode.

Table 137. STM32L4Rxxx/4Sxxx configuration in system memory boot mode (continued)

Bootloader	Feature/Peripheral	State	Comment
SPI1 bootloader	SPI1	Enabled	The SPI1 configuration is: – Slave mode – Full Duplex – 8-bit MSB – Speed up to 8 MHz – Polarity: CPOL Low, CPHA Low, NSS hardware.
	SPI1_MOSI pin	Input	PA7 pin: Slave data Input line, used in push-pull, pull-down mode
	SPI1_MISO pin	Output	PA6 pin: Slave data output line, used in push-pull, pull-down mode
	SPI1_SCK pin	Input	PA5 pin: Slave clock line, used in push-pull, pull-down mode
	SPI1_NSS pin	Input	PA4 pin: slave chip select pin used in push-pull, pull-down mode. Note: This IO can be tied to GND if the SPI Master does not use it.
SPI2 bootloader	SPI2	Enabled	The SPI2 configuration is: – Slave mode – Full Duplex – 8-bit MSB – Speed up to 8 MHz – Polarity: CPOL Low, CPHA Low, NSS hardware.
	SPI2_MOSI pin	Input	PB15 pin: Slave data Input line, used in push-pull, pull-down mode
	SPI2_MISO pin	Output	PB14 pin: Slave data output line, used in push-pull, pull-down mode
	SPI2_SCK pin	Input	PB13 pin: Slave clock line, used in push-pull, pull-down mode
	SPI2_NSS pin	Input	PB12 pin: slave chip select pin used in push-pull, pull-down mode. Note: This IO can be tied to GND if the SPI Master does not use it.
CAN1 bootloader	CAN1	Enabled	Once initialized the CAN1 configuration is: Baudrate 125 kbps, 11 -bit identifier.
	CAN1_RX pin	Input	PB8 pin: CAN1 in reception mode
	CAN1_TX pin	Output	PB9 pin: CAN1 in transmission mode
	TIM16	Enabled	This timer is used to determine the value of the HSE. Once the HSE frequency is determined, the system clock is configured to 60 MHz using PLL and HSE.

Table 137. STM32L4Rxxx/4Sxxx configuration in system memory boot mode (continued)

Bootloader	Feature/Peripheral	State	Comment
DFU bootloader	USB	Enabled	USB FS configured in forced device mode. USB FS interrupt vector is enabled and used for USB DFU communications. Note: VDDUSB IO must be connected to 3.3 V as USB peripheral is used by the bootloader.
	USB_DM pin	Input/Output	PA11: USB DM line.
	USB_DP pin		PA12: USB DP line No external pull-up resistor is required

63.2 Bootloader selection

Figure 86 and Figure 87 show the bootloader selection mechanisms.

Figure 86. Dual bank boot implementation for STM32L4Rxxx/STM32L4Sxxx bootloader V9.x

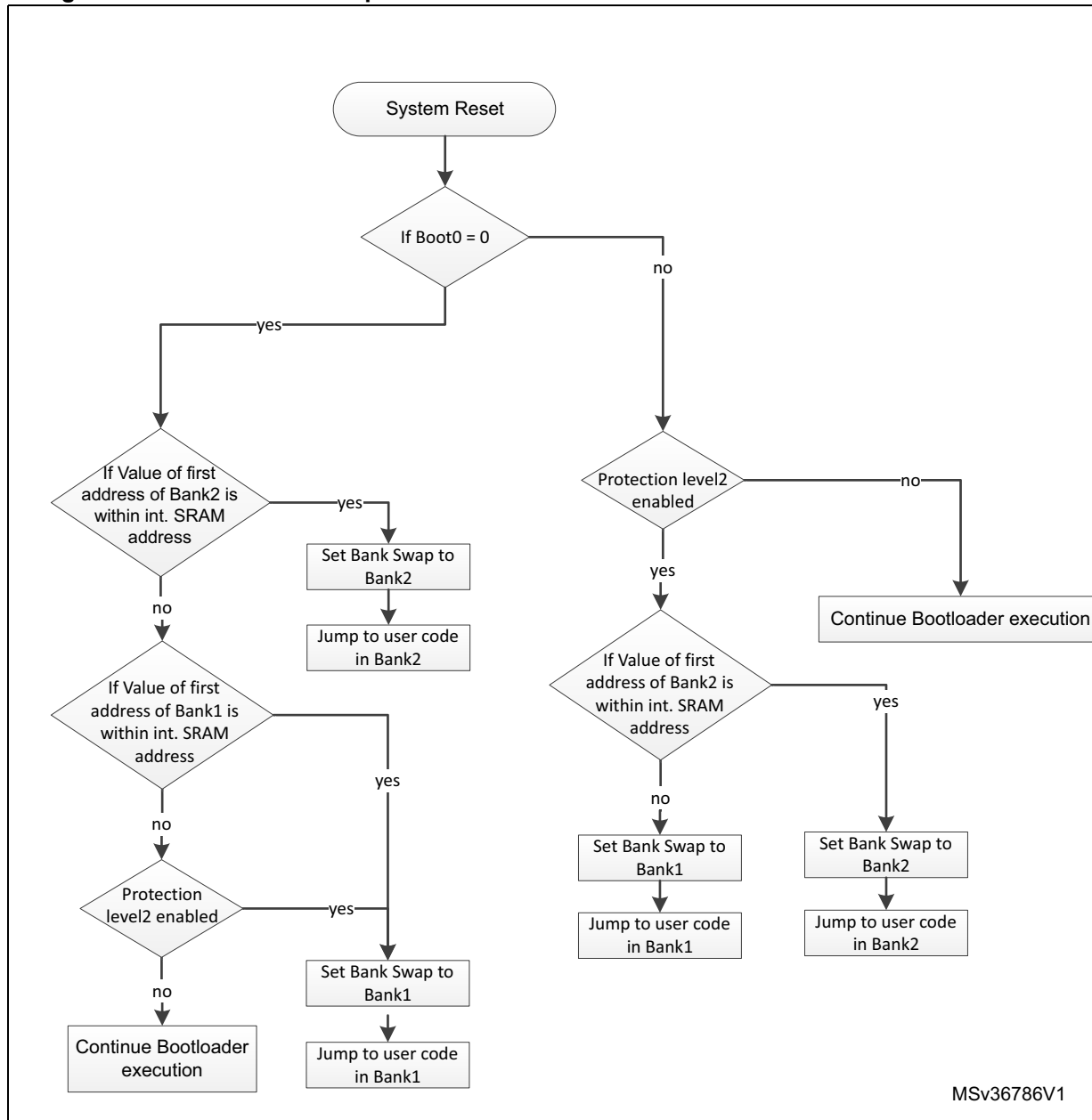
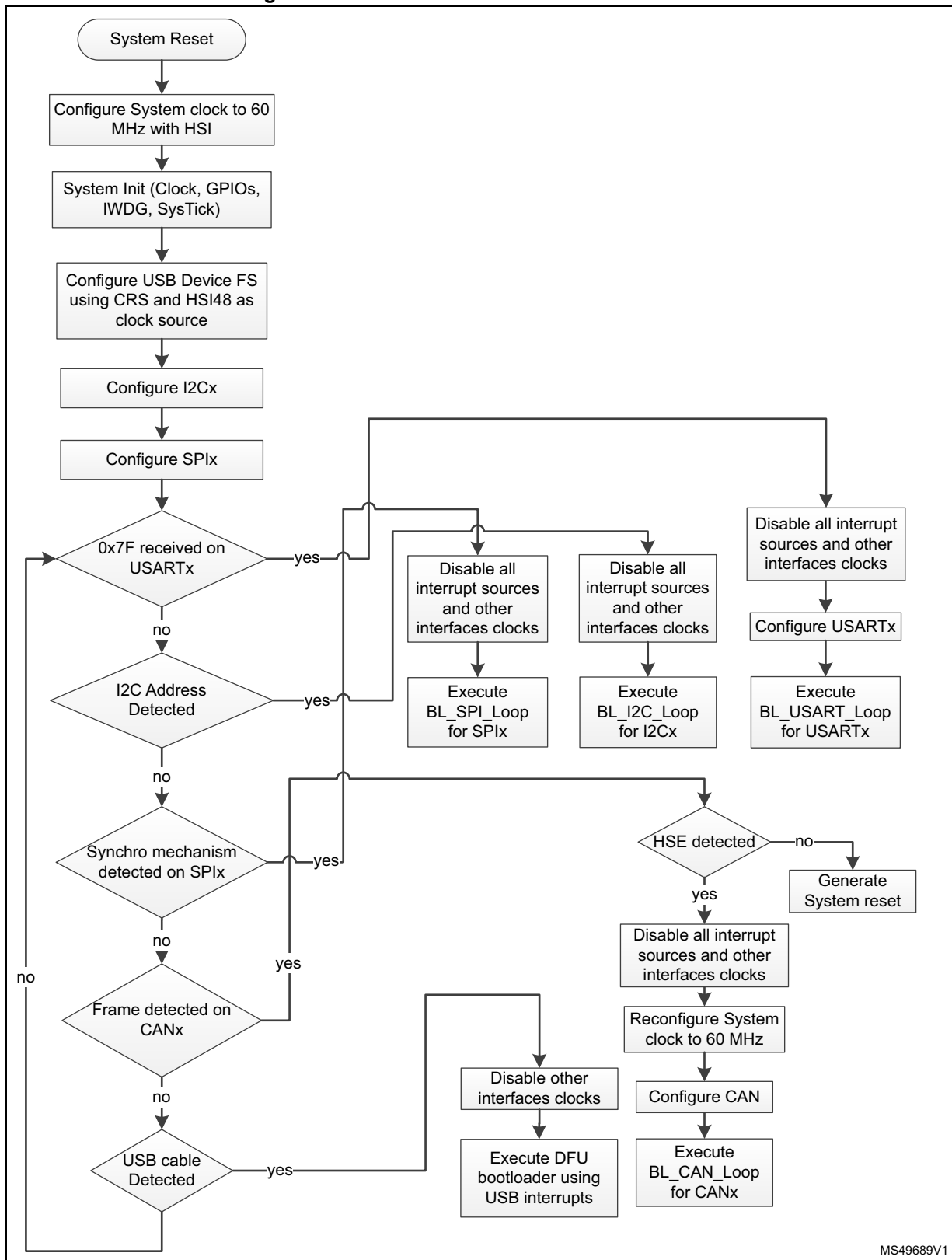

Figure 87.Bootloader V9.x selection for STM32L4Rxx/4Sxx



63.3 Bootloader version

[Table 138](#) lists the STM32L4Rxx/4Sxx devices bootloader versions.

Table 138. STM32L4Rxx/4Sxx bootloader versions

Bootloader version number	Description	Known limitations
V9.0	Initial bootloader version on cut 1.0 samples	– None

64 STM32L552xx/STM32L562xx devices bootloader

64.1 Bootloader configuration

The STM32L552xx/562xx bootloader is activated by applying Pattern 12 (described in [Table 2: Bootloader activation patterns](#)). The following table shows the hardware resources used by this bootloader.

Table 139. STM32L552xx/562xx configuration in system memory boot mode

Bootloader	Feature/Peripheral	State	Comment
Common to all bootloaders	RCC	HSI enabled	The system clock frequency is 60 MHz (using PLL clocked by HSI).
		-	The clock recovery system (CRS) is enabled for the DFU bootloader to allow USB to be clocked by HSI 48 MHz.
		-	20 MHz derived from the PLLQ is used for FDCAN
	RAM	-	16 Kbytes starting from address 0x20000000 are used by the bootloader firmware
	System memory	-	32 Kbytes starting from address 0x0BF90000.
	IWDG	-	The independent watchdog (IWDG) prescaler is configured to its maximum value. It is periodically refreshed to prevent watchdog reset (in case the hardware IWDG option was previously enabled by the user).
USART1 bootloader	USART1	Enabled	Once initialized the USART1 configuration is: 8-bit, even parity and 1 Stop bit
	USART1_RX pin	Input	PA10 pin: USART1 in reception mode
	USART1_TX pin	Output	PA9 pin: USART1 in transmission mode
USART2 bootloader	USART2	Enabled	Once initialized the USART2 configuration is: 8-bit, even parity and 1 Stop bit
	USART2_RX pin	Input	PA3 pin: USART2 in reception mode
	USART2_TX pin	Output	PA2 pin: USART2 in transmission mode
USART3 bootloader	USART3	Enabled	Once initialized the USART3 configuration is: 8-bit, even parity and 1 Stop bit
	USART3_RX pin	Input	PC11 pin: USART3 in reception mode
	USART3_TX pin	Output	PC10 pin: USART3 in transmission mode

Table 139. STM32L552xx/562xx configuration in system memory boot mode (continued)

Bootloader	Feature/Peripheral	State	Comment
I2C1 bootloader	I2C1	Enabled	The I2C1 configuration is: I2C speed: up to 1 MHz, 7-bit address, slave mode, analog filter ON. Slave 7-bit address: 0b0101100x (where x = 0 for write and x = 1 for read)
	I2C1_SCL pin	Input/Output	PB6 pin: clock line is used in open-drain mode.
	I2C1_SDA pin	Input/Output	PB7 pin: data line is used in open-drain mode.
I2C2 bootloader	I2C2	Enabled	The I2C2 configuration is: I2C speed: up to 1 MHz, 7-bit address, slave mode, analog filter ON. Slave 7-bit address: 0b0101100x (where x = 0 for write and x = 1 for read)
	I2C2_SCL pin	Input/Output	PB10 pin: clock line is used in open-drain mode.
	I2C2_SDA pin	Input/Output	PB11 pin: data line is used in open-drain mode.
I2C3 bootloader	I2C3	Enabled	The I2C3 configuration is: I2C speed: up to 1 MHz, 7-bit address, slave mode, analog filter ON. Slave 7-bit address: 0b0101100x (where x = 0 for write and x = 1 for read)
	I2C3_SCL pin	Input/Output	PC0 pin: clock line is used in open-drain mode.
	I2C3_SDA pin	Input/Output	PC1 pin: data line is used in open-drain mode.
SPI1 bootloader	SPI1	Enabled	The SPI1 configuration is: – Slave mode – Full Duplex – 8-bit MSB – Speed up to 8 MHz – Polarity: CPOL Low, CPHA Low, NSS hardware.
	SPI1_MOSI pin	Input	PA7 pin: Slave data Input line, used in push-pull, pull-down mode
	SPI1_MISO pin	Output	PA6 pin: Slave data output line, used in push-pull, pull-down mode
	SPI1_SCK pin	Input	PA5 pin: Slave clock line, used in push-pull, pull-down mode
	SPI1_NSS pin	Input	PA4 pin: slave chip select pin used in push-pull, pull-down mode. Note: This IO can be tied to GND if the SPI Master does not use it.

Table 139. STM32L552xx/562xx configuration in system memory boot mode (continued)

Bootloader	Feature/Peripheral	State	Comment
SPI2 bootloader	SPI2	Enabled	The SPI2 configuration is: – Slave mode – Full Duplex – 8-bit MSB – Speed up to 8 MHz – Polarity: CPOL Low, CPHA Low, NSS hardware.
	SPI2_MOSI pin	Input	PB15 pin: Slave data Input line, used in push-pull, pull-down mode
	SPI2_MISO pin	Output	PB14 pin: Slave data output line, used in push-pull, pull-down mode
	SPI2_SCK pin	Input	PB13 pin: Slave clock line, used in push-pull, pull-down mode
	SPI2_NSS pin	Input	PB12 pin: slave chip select pin used in push-pull, pull-down mode. Note: This IO can be tied to GND if the SPI Master does not use it.
SPI3 bootloader	SPI3	Enabled	The SPI configuration is: – Slave mode – Full Duplex – 8-bit MSB – Speed up to 8 MHz – Polarity: CPOL Low, CPHA Low, NSS hardware.
	SPI3_MOSI pin	Input	PB5 pin: Slave data Input line, used in push-pull, pull-down mode
	SPI3_MISO pin	Output	PG10 pin: Slave data output line, used in push-pull, pull-down mode
	SPI3_SCK pin	Input	PG9 pin: Slave clock line, used in push-pull, pull-down mode
	SPI3_NSS pin	Input	PG12 pin: slave chip select pin used in push-pull, pull-down mode. Note: This IO can be tied to GND if the SPI Master does not use it.
FDCAN bootloader	FDCAN1	Enabled	Once initialized the FDCAN1 configuration is: Bitrate 0.5 Mbps FrameFormat = FDCAN_FRAME_FD_BRS Mode = FDCAN_MODE_NORMAL AutoRetransmission = ENABLE TransmitPause = DISABLE ProtocolException = ENABLE
	FDCAN1_Rx pin	Input/	PB9 pin: FDCAN1 in reception mode
	FDCAN1_Tx pin	Output	PB8 pin: FDCAN1 in transmission mode

Table 139. STM32L552xx/562xx configuration in system memory boot mode (continued)

Bootloader	Feature/Peripheral	State	Comment
DFU bootloader	USB	Enabled	USB FS configured in forced device mode. USB FS interrupt vector is enabled and used for USB DFU communications. Note: VDDUSB IO must be connected to 3.3 V as USB peripheral is used by the bootloader.
	USB_DM pin	Input/Output	PA11: USB DM line.
	USB_DP pin		PA12: USB DP line No external pull-up resistor is required

64.2 Bootloader selection

The figure below shows the bootloader selection mechanism.

Figure 88. Bootloader V9.x selection for STM32L552xx/562xx

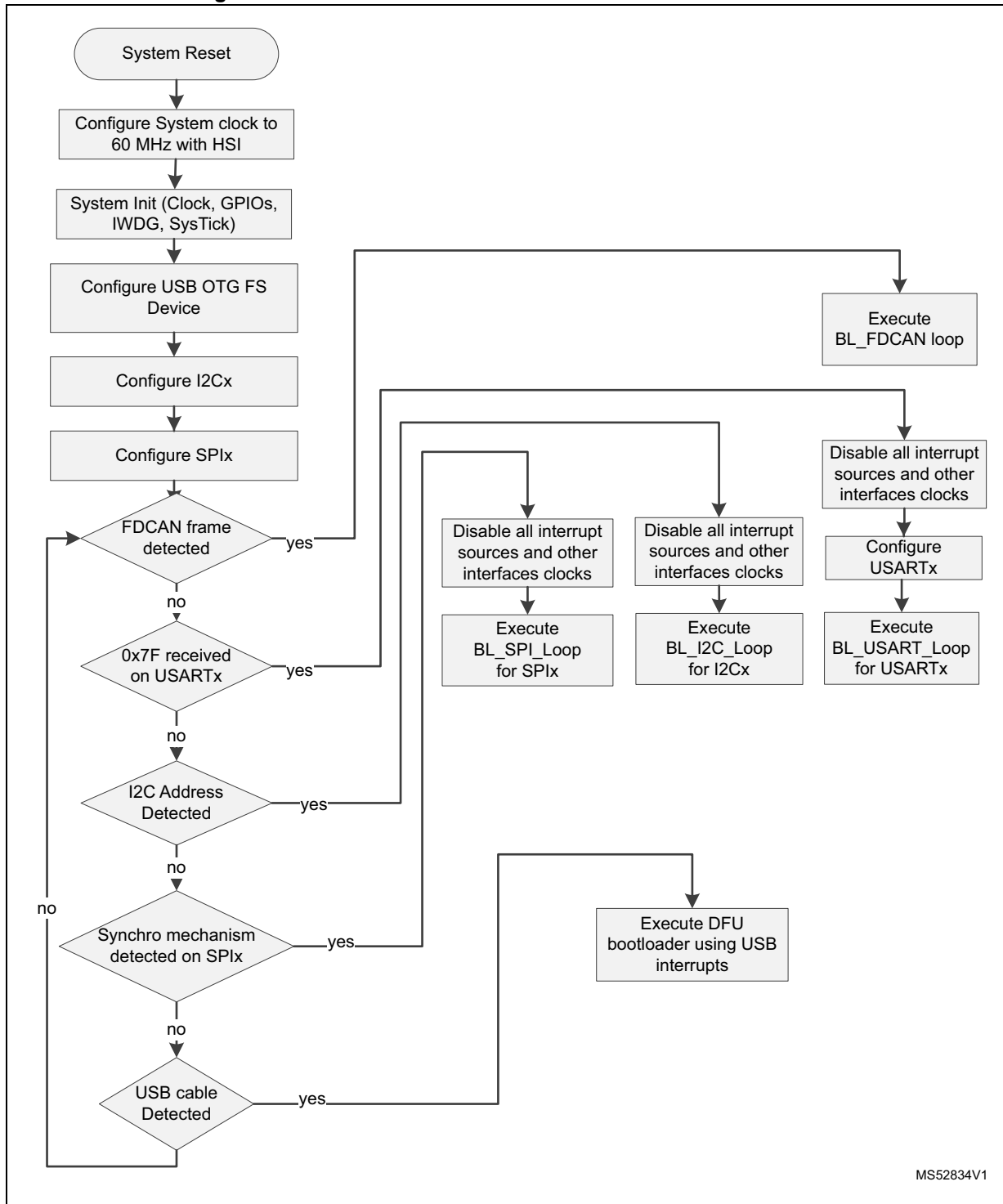

64.3 Bootloader version

Table 140 lists the STM32L552xx/562xx devices bootloader versions.

Table 140. STM32L552xx/562xx bootloader versions

Bootloader version number	Description	Known limitations
V13.0	Initial bootloader version on cut1.0 samples	<ul style="list-style-type: none"> – USART3 not working – SPI3 not working – OB launch not working on USB-DFU – No read/write SRAM2 in all protocols – Read Secure Option bytes only implemented on USART/I2C – Regression from TZen = 1 to TZen = 0 is done automatically on RDP regression
V9.0	Release supported only in cut2.0 – Fix all issues on previous release – Add FDCAN support – New command added for TZen disable – Support of sales type 256KB	<ul style="list-style-type: none"> – Not able to set TZen to 1 option byte using all interfaces of the BL No WA available – Cannot set RDP level 0.5 nor option bytes in RDP level 0.5 using BL interfaces No WA available – Multiple reset seen when enabling HW IWDG option byte in TZen = 1 No WA available – Not able to set secure option bytes setting when TZen = 1 and RDP level is 0 No WA available – “Go” Command on USB is not working
V9.1	<ul style="list-style-type: none"> – Fix all known limitations of previous release – Add enable BOOT_LOCK BL command – Add support of RDP L1 to 0.5 regression 	Option byte programming is not working properly when using FDCAN interface This makes the change of the Option byte not effective until a power off power on.
V9.2	<ul style="list-style-type: none"> – Fix all known limitations of previous release – Version for silicon revision Z 	None

Note: When jumping to the BL the cache must be disabled.

65 STM32WB30xx/35xx/50xx/55xx devices bootloader

65.1 Bootloader configuration

The STM32WBxxx bootloader is activated by applying Pattern 16 (described in [Table 2: Bootloader activation patterns](#)). [Table 141](#) shows the hardware resources used by this bootloader.

Table 141. STM32WB30xx/35xx/50xx/55xx configuration in system memory boot mode

Bootloader	Feature/Peripheral	State	Comment
Common to all bootloaders	RCC	MSI enabled	The system clock frequency is 64 MHz (using PLL clocked by MSI).
		-	The clock recovery system (CRS) is enabled for the DFU bootloader to allow USB to be clocked by HSI 48 MHz.
	RAM	-	20 Kbytes starting from address 0x20000000 are used by the bootloader firmware
	System memory	-	28 Kbytes starting from address 0x1FFF0000, contain the bootloader firmware
	IWDG	-	The independent watchdog (IWDG) prescaler is configured to its maximum value. It is periodically refreshed to prevent watchdog reset (in case the hardware IWDG option was previously enabled by the user).
USART1 bootloader	USART1	Enabled	Once initialized the USART1 configuration is: 8-bit, even parity and 1 Stop bit
	USART1_RX pin	Input	PA10 pin: USART1 in reception mode
	USART1_TX pin	Output	PA9 pin: USART1 in transmission mode
I2C1 bootloader	I2C1	Enabled	The I2C1 configuration is: I2C speed: up to 1 MHz, 7-bit address, slave mode, analog filter ON. Slave 7-bit address: 0b1001111x (where x = 0 for write and x = 1 for read)
	I2C1_SCL pin	Input/Output	PB6 pin: clock line is used in open-drain mode.
	I2C1_SDA pin	Input/Output	PB7 pin: data line is used in open-drain mode.

Table 141. STM32WB30xx/35xx/50xx/55xx configuration in system memory boot mode

Bootloader	Feature/Peripheral	State	Comment
I2C3 bootloader	I2C3	Enabled	The I2C3 configuration is: I2C speed: up to 1 MHz, 7-bit address, slave mode, analog filter ON. Slave 7-bit address: 0b1001111x (where x = 0 for write and x = 1 for read)
	I2C3_SCL pin	Input/Output	PC0 pin: clock line is used in open-drain mode.
	I2C3_SDA pin	Input/Output	PC1 pin: data line is used in open-drain mode.
SPI1 bootloader	SPI1	Enabled	The SPI1 configuration is: – Slave mode – Full Duplex – 8-bit MSB – Speed up to 8 MHz – Polarity: CPOL Low, CPHA Low, NSS hardware.
	SPI1_MOSI pin	Input	PA7 pin: Slave data Input line, used in push-pull, pull-down mode
	SPI1_MISO pin	Output	PA6 pin: Slave data output line, used in push-pull, pull-down mode
	SPI1_SCK pin	Input	PA5 pin: Slave clock line, used in push-pull, pull-down mode
	SPI1_NSS pin	Input	PA4 pin: slave chip select pin used in push-pull, pull-down mode. Note: This IO can be tied to GND if the SPI Master does not use it.
SPI2 bootloader	SPI2	Enabled	The SPI2 configuration is: – Slave mode – Full Duplex – 8-bit MSB – Speed up to 8 MHz – Polarity: CPOL Low, CPHA Low, NSS hardware.
	SPI2_MOSI pin	Input	PB15 pin: Slave data Input line, used in push-pull, pull-down mode
	SPI2_MISO pin	Output	PB14 pin: Slave data output line, used in push-pull, pull-down mode
	SPI2_SCK pin	Input	PB13 pin: Slave clock line, used in push-pull, pull-down mode
		SPI2_NSS pin	Input

Table 141. STM32WB30xx/35xx/50xx/55xx configuration in system memory boot mode

Bootloader	Feature/Peripheral	State	Comment
DFU bootloader	USB	Enabled	USB FS configured in forced device mode. USB FS interrupt vector is enabled and used for USB DFU communications. Note: VDDUSB IO must be connected to 3.3 V as USB peripheral is used by the bootloader.
	USB_DM pin	Input/Output	PA11: USB DM line.
	USB_DP pin		PA12: USB DP line No external pull-up resistor is required

65.2 Bootloader selection

The figure below shows the bootloader selection mechanism.

Figure 89. Bootloader V13.0 selection for STM32WB30xx/35xx/50xx/55xx

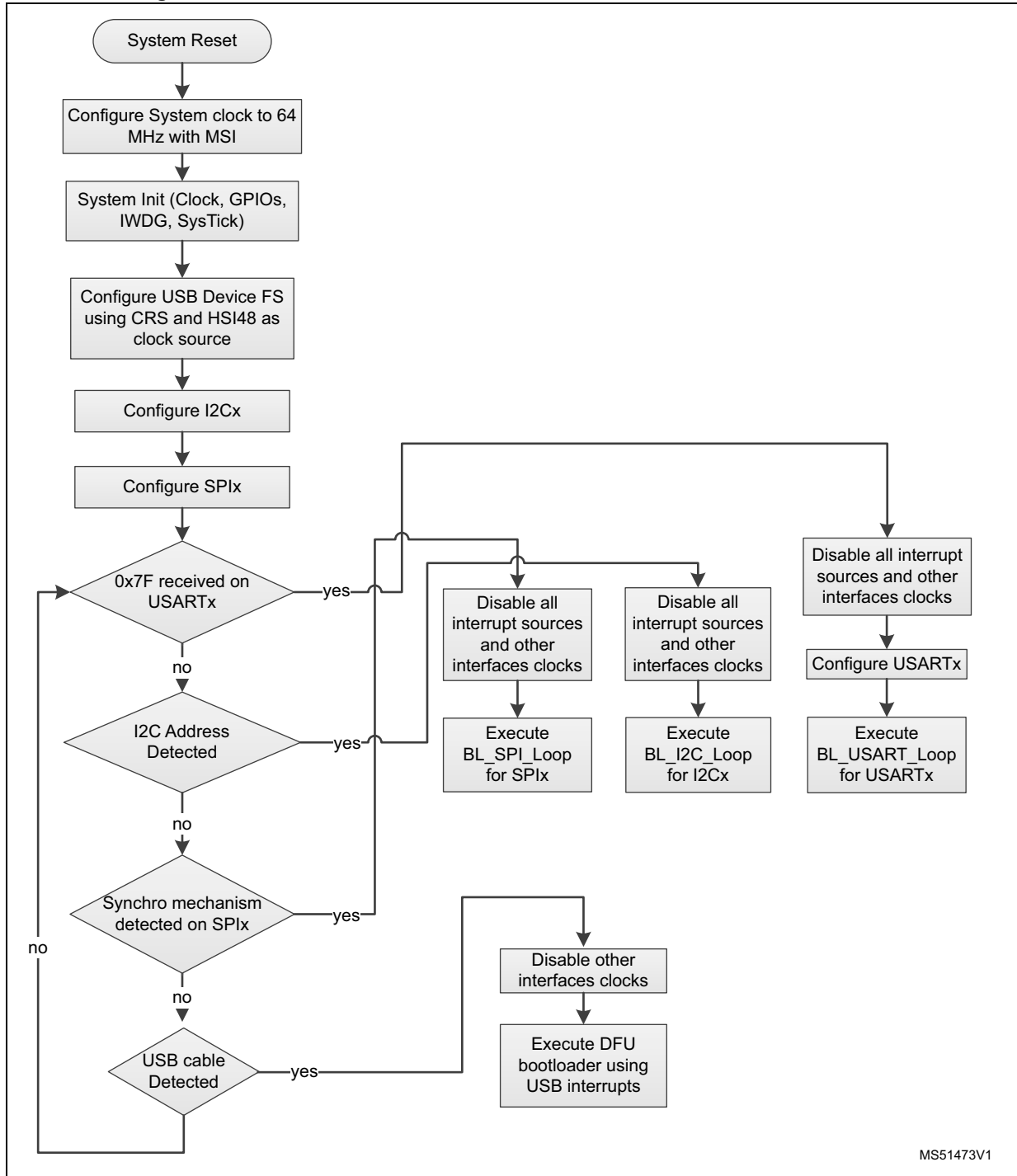

65.3 Bootloader version

Table 142. STM32WB30xx/35xx/50xx/55xx bootloader versions

Bootloader version number	Description	Known limitations
V13.5	Initial bootloader version	– Readout Unprotect Command is not working properly as at the end of the command an NVIC_SystemReset is done instead of a Flash option bytes reload. This makes the change of the RDP level not effective until a power off power on.

Note: Instability when performing multiple resets during operations ongoing causing Overrun or FrameError errors on USART Bootloader and not recoverable unless Hardware Reset is performed. Fixed by workaround in FUS V1.0.1 and V1.0.2.

66 STM32WLE5xx/55xx devices bootloader

66.1 Bootloader configuration

The STM32WLE5xx/55xx bootloader is activated by applying Pattern 13 (described in [Table 2: Bootloader activation patterns](#)). [Table 143](#) shows the hardware resources used by this bootloader.

Table 143. STM32WLE5xx/55xx configuration in system memory boot mode

Bootloader	Feature/Peripheral	State	Comment
Common to all bootloaders	RCC	HSI enabled	The system clock frequency is 48 MHz (using PLL clocked by HSI).
	RAM	-	8 Kbytes starting from address 0x20000000 are used by the bootloader firmware
	System memory	-	16 Kbytes starting from address 0x1FFF0000, contain the bootloader firmware
	IWDG	-	The independent watchdog (IWDG) prescaler is configured to its maximum value. It is periodically refreshed to prevent watchdog reset (in case the hardware IWDG option was previously enabled by the user).
USART1 bootloader	USART1	Enabled	Once initialized the USART1 configuration is: 8-bit, even parity and 1 Stop bit
	USART1_RX pin	Input	PA10 pin: USART1 in reception mode
	USART1_TX pin	Output	PA9 pin: USART1 in transmission mode
USART2 bootloader	USART2	Enabled	Once initialized the USART1 configuration is: 8-bit, even parity and 1 Stop bit
	USART2_RX pin	Input	PA3 pin: USART1 in reception mode
	USART2_TX pin	Output	PA2 pin: USART1 in transmission mode

Table 143. STM32WLE5xx/55xx configuration in system memory boot mode (continued)

Bootloader	Feature/Peripheral	State	Comment
SPI1 bootloader	SPI1	Enabled	The SPI1 configuration is: <ul style="list-style-type: none"> – Slave mode – Full Duplex – 8-bit MSB – Speed up to 8 MHz – Polarity: CPOL Low, CPHA Low, NSS hardware.
	SPI1_MOSI pin	Input	PA7 pin: Slave data Input line, used in push-pull, pull-down mode
	SPI1_MISO pin	Output	PA6 pin: Slave data output line, used in push-pull, pull-down mode
	SPI1_SCK pin	Input	PA5 pin: Slave clock line, used in push-pull, pull-down mode
	SPI1_NSS pin	Input	PA4 pin: slave chip select pin used in push-pull, pull-down mode. Note: This IO can be tied to GND if the SPI Master does not use it.
SPI2 bootloader	SPI2	Enabled	The SPI2 configuration is: <ul style="list-style-type: none"> – Slave mode – Full Duplex – 8-bit MSB – Speed up to 8 MHz – Polarity: CPOL Low, CPHA Low, NSS hardware.
	SPI2_MOSI pin	Input	PB15 pin: Slave data Input line, used in push-pull, pull-down mode
	SPI2_MISO pin	Output	PB14 pin: Slave data output line, used in push-pull, pull-down mode
	SPI2_SCK pin	Input	PB13 pin: Slave clock line, used in push-pull, pull-down mode
	SPI2_NSS pin	Input	PB12 pin: slave chip select pin used in push-pull, pull-down mode. Note: This IO can be tied to GND if the SPI Master does not use it.

66.2 Bootloader selection

Figure 90 shows the bootloader selection mechanism.

Figure 90. Bootloader V12.x selection for STM32WLE5xx/55xx

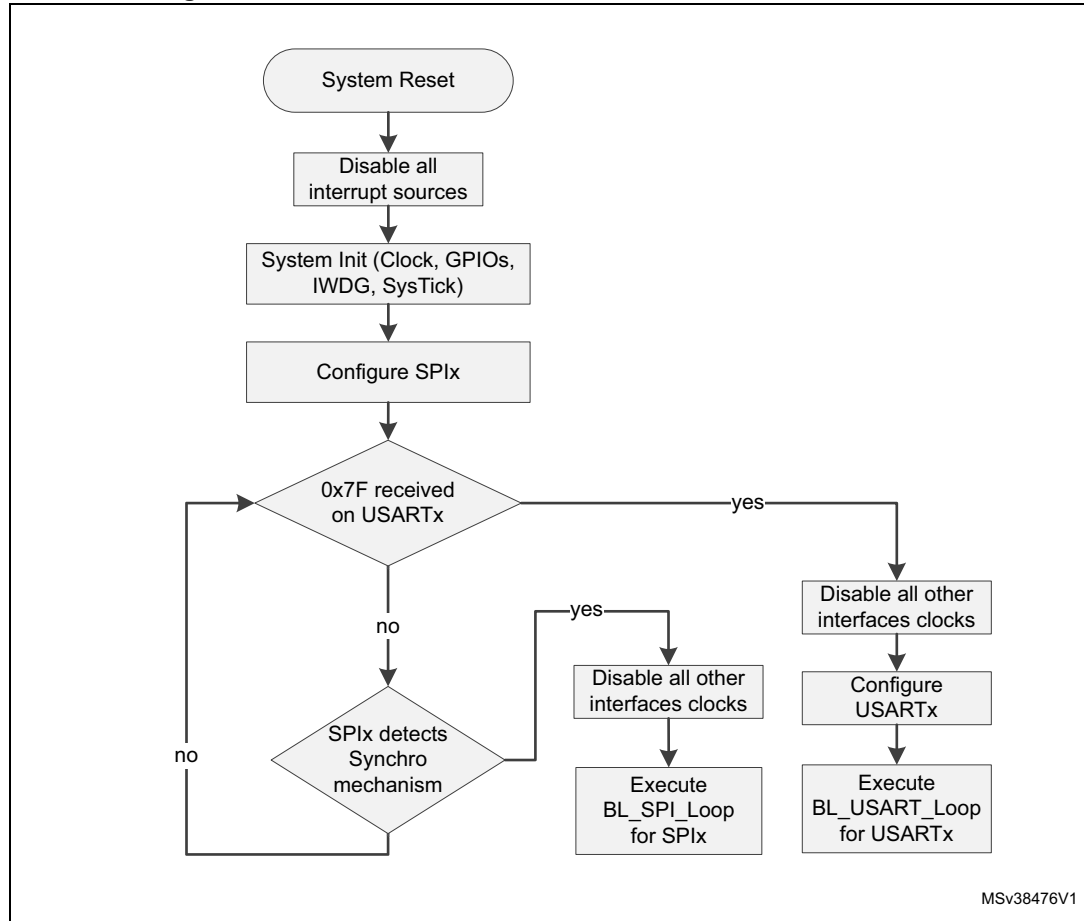

66.3 Bootloader version

Table 144. STM32WLE5xx/55xx bootloader versions

Bootloader version number	Description	Known limitations
V12.2	Initial bootloader version on rev. Z samples	None
V12.3	Final bootloader version on rev Z samples	None

67 Device-dependent bootloader parameters

The bootloader protocol command set and sequences for each serial peripheral are the same for all STM32 devices. However, some parameters depend on device and bootloader version:

- PID (Product ID)
- Valid RAM memory addresses (RAM area used during bootloader execution is not accessible) accepted by the bootloader when the Read Memory, Go and Write Memory commands are requested.
- System Memory area.

[Table 145](#) shows the values of these parameters for each STM32 device.

Table 145. Bootloader device-dependent parameters

STM32 Series	Device	PID	BL ID	RAM	System memory
F0	STM32F05xxx and STM32F030x8	0x440	0x21	0x20000800 - 0x20001FFF	0x1FFFE000 - 0x1FFFF7FF
	STM32F03xx4/6	0x444	0x10	0x20000800 - 0x20000FFF	
	STM32F030xC	0x442	0x52	0x20001800 - 0x20007FFF	0x1FFFD800 - 0x1FFFF7FF
	STM32F04xxx	0x445	0xA1	NA	0x1FFFC400 - 0x1FFFF7FF
	STM32F070x6	0x445	0xA2	NA	0x1FFFC400 - 0x1FFFF7FF
	STM32F070xB	0x448	0xA2	NA	0x1FFFC800 - 0x1FFFF7FF
	STM32F071xx/072xx	0x448	0xA1	0x20001800 - 0x20003FFF	0x1FFFC800 - 0x1FFFF7FF
	STM32F09xxx	0x442	0x50	NA	0x1FFFD800 - 0x1FFFF7FF

Table 145. Bootloader device-dependent parameters (continued)

STM32 Series	Device		PID	BL ID	RAM	System memory
F1	STM32F10xxx	Low-density	0x412	NA	0x20000200 - 0x200027FF	0x1FFFF000 - 0x1FFFF7FF
		Medium-density	0x410	NA	0x20000200 - 0x20004FFF	
		High-density	0x414	NA	0x20000200 - 0x2000FFFF	
		Medium-density value line	0x420	0x10	0x20000200 - 0x20001FFF	
		High-density value line	0x428	0x10	0x20000200 - 0x20007FFF	
	STM32F105xx/107xx		0x418	NA	0x20001000 - 0x2000FFFF	0x1FFFB000 - 0x1FFFF7FF
	STM32F10xxx XL-density		0x430	0x21	0x20000800 - 0x20017FFF	0x1FFFE000 - 0x1FFFF7FF
F2	STM32F2xxxx		0x411	0x20	0x20002000 - 0x2001FFFF	0x1FFF0000 - 0x1FFF77FF
				0x33		
F3	STM32F373xx		0x432	0x41	0x20001400 - 0x20007FFF	0x1FFFD800 - 0x1FFFF7FF
	STM32F378xx			0x50	0x20001000 - 0x20007FFF	
	STM32F302xB(C)/303xB(C)		0x422	0x41	0x20001400 - 0x20009FFF	
	STM32F358xx			0x50		
	STM32F301xx/302x4(6/8)		0x439	0x40	0x20001800 - 0x20003FFF	
	STM32F318xx			0x50		
	STM32F303x4(6/8)/334xx/328xx		0x438	0x50	0x20001800 - 0x20002FFF	
	STM32F302xD(E)/303xD(E)		0x446	0x40	0x20001800 - 0x2000FFFF	
	STM32F398xx		0x446	0x50	0x20001800 - 0x2000FFFF	

Table 145. Bootloader device-dependent parameters (continued)

STM32 Series	Device	PID	BL ID	RAM	System memory
F4	STM32F40xxx/41xxx	0x413	0x31	0x20002000 - 0x2001FFFF	0x1FFF0000 - 0x1FFF77FF
			0x90	0x20003000 - 0x2001FFFF	
	STM32F42xxx/43xxx	0x419	0x70	0x20003000 - 0x2002FFFF	
			0x91	0x2002FFFF	
	STM32F401xB(C)	0x423	0xD1	0x20003000 - 0x2000FFFF	
	STM32F401xD(E)	0x433	0xD1	0x20003000 - 0x20017FFF	
	STM32F410xx	0x458	0xB1	0x20003000 - 0x20007FFF	
	STM32F411xx	0x431	0xD0	0x20003000 - 0x2001FFFF	
	STM32F412xx	0x441	0x90	0x20003000 - 0x2003FFFF	
	STM32F446xx	0x421	0x90	0x20003000 - 0x2001FFFF	
	STM32F469xx/479xx	0x434	0x90	0x20003000 - 0x2005FFFF	
STM32F413xx/423xx	0x463	0x90	0x20003000 - 0x2004FFFF		
F7	STM32F72xxx/73xxx	0x452	0x90	0x20004000 - 0x2003FFFF	0x1FF00000 - 0x1FF0EDBF
	STM32F74xxx/75xxx	0x449	0x70	0x20004000 - 0x2004FFFF	0x1FF00000 - 0x1FF0EDBF
			0x90	0x20004000 - 0x2004FFFF	0x1FF00000 - 0x1FF0EDBF
	STM32F76xxx/77xxx	0x451	0x93	0x20004000 - 0x2007FFFF	0x1FF00000 - 0x1FF0EDBF
G0	STM32G03xxx/04xxx	0x466	0x52	0x20001000 - 0x20001FFF	0x1FFF0000 - 0x1FFF1FFF
	STM32G07xxx/08xxx	0x460	0xB2	0x20002700 - 0x20009000	0x1FFF0000 - 0x1FFF6FFF
	STM32G0B0xx	0x467	0xD0	0x20004000 - 0x20020000	0x1FFF0000 - 0x1FFF6FFF 0x1FFF8000 - 0x1FFFEFFF
	STM32G0B1xx/0C1xx	0x467	0x92	0x20004000 - 0x20020000	0x1FFF0000 - 0x1FFF6FFF 0x1FFF8000 - 0x1FFFEFFF

Table 145. Bootloader device-dependent parameters (continued)

STM32 Series	Device	PID	BL ID	RAM	System memory
G4	STM32G431xx/441xx	0x468	0xD4	0x20004000 – 0x20005800	0x1FFF0000 - 0x1FFF7000
	STM32G47xxx/48xxx	0x469	0xD5	0x20004000 – 0x20018000	0x1FFF0000 - 0x1FFF7000
H7	STM32H72xxx/73xxx	0x483	0x91	0x20004100 - 0x2001FFFF 0x24004000 - 0x2404FFFF	0x1FF00000 - 0x1FF1E7FF
	STM32H74xxx/75xxx	0x450	0x90	0x20004100 - 0x2001FFFF 0x24034000 - 0x2407FFFF	0x1FF00000 - 0x1FF1E7FF
	STM32H7A3xx/B3xx	0x480	0x90	0x20004100 - 0x2001FFFF 0x24034000 - 0x2407FFFF	0x1FF00000 - 0x1FF13FFF
L0	STM32L01xxx/02xxx	0x457	0xC3	NA	0x1FF00000 - 0x1FF00FFF
	STM32L031xx/041xx	0x425	0xC0	0x20001000 - 0x20001FFF	0x1FF00000 - 0x1FF00FFF
	STM32L05xxx/06xxx	0x417	0xC0	0x20001000 - 0x20001FFF	0x1FF00000 - 0x1FF00FFF
	STM32L07xxx/08xxx	0x447	0x41	0x20001000 - 0x20004FFF	0x1FF00000 - 0x1FF01FFF
0xB2			0x20001400 - 0x20004FFF		
L1	STM32L1xxx6(8/B)	0x416	0x20	0x20000800 - 0x20003FFF	0x1FF00000 - 0x1FF01FFF
	STM32L1xxx6(8/B)A	0x429	0x20	0x20001000 - 0x20007FFF	
	STM32L1xxxC	0x427	0x40		
	STM32L1xxxD	0x436	0x45	0x20001000 - 0x2000BFFF	
	STM32L1xxxE	0x437	0x40	0x20001000 - 0x20013FFF	

Table 145. Bootloader device-dependent parameters (continued)

STM32 Series	Device	PID	BL ID	RAM	System memory
L4	STM32L412xx/422xx	0x464	0xD1	0x20002100 - 0x20008000	0x1FFF0000 - 0x1FFF6FFF
	STM32L43xxx/44xxx	0x435	0x91	0x20003100 - 0x2000BFFF	0x1FFF0000 - 0x1FFF6FFF
	STM32L45xxx/46xxx	0x462	0x92	0x20003100 - 0x2001FFFF	0x1FFF0000 - 0x1FFF6FFF
	STM32L47xxx/48xxx	0x415	0xA3	0x20003000 - 0x20017FFF	0x1FFF0000 - 0x1FFF6FFF
			0x92	0x20003100 - 0x20017FFF	
	STM32L496xx/4A6xx	0x461	0x93	0x20003100 - 0x2003FFFF	0x1FFF0000 - 0x1FFF6FFF
	STM32L4Rxx/4Sxx	0x470	0x95	0x20003200 - 0x2009FFFF	0x1FFF0000 - 0x1FFF6FFF
STM32L4P5xx/Q5xx	0x471	0x90	0x20004000 - 0x2004FFFF	0x1FFF0000 - 0x1FFF6FFF	
L5	STM32L552xx/562xx	0x472	0x92	0x20004000 - 0x2003FFFF	0x0BF90000 - 0x0BF97FFF
WB	STM32WB30xx/35xx/50xx/WB55xx	0x495	0xD5	0x20005000 - 0x20040000	0x1FFF0000 - 0x1FFF7000
WL	STM32WLE5xx/WL55xx	0x497	0xC3	0x20002000 - 0x2000FFFF	0x1FFF0000 - 0x1FFF3FFF

68 Bootloader timings

This section presents the typical timings of the bootloader firmware to be used to ensure correct synchronization between host and STM32 device.

Two types of timings are described:

- STM32 device bootloader resources initialization duration.
- Communication interface selection duration.

After these timings the bootloader is ready to receive and execute host commands.

68.1 Bootloader startup timing

After bootloader reset, the host must wait until the STM32 bootloader is ready to start detection phase with a specific interface communication. This time corresponds to bootloader startup timing, during which resources used by bootloader are initialized.

Figure 91. Bootloader Startup timing description

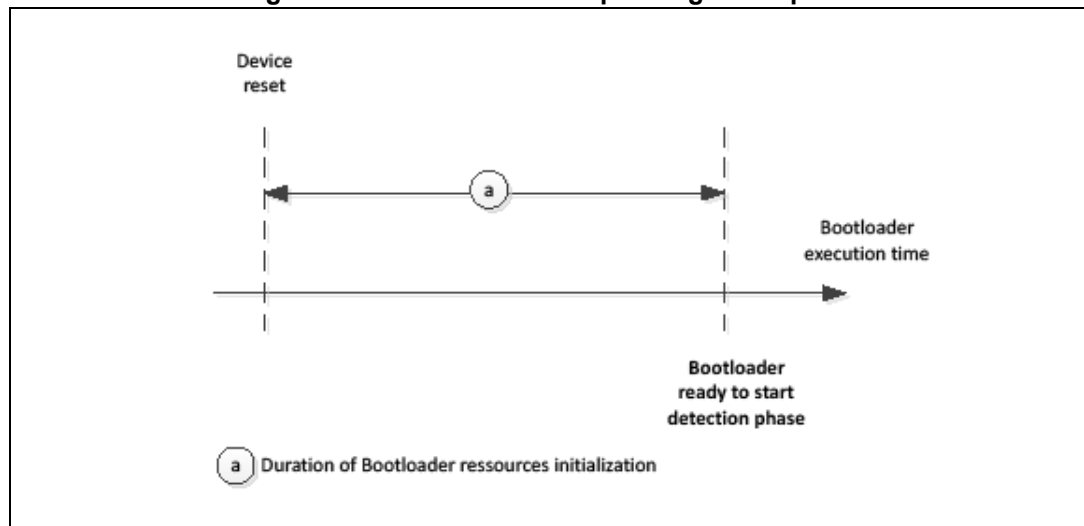

Table 146. Bootloader startup timings (ms) for STM32 devices

Device	Minimum bootloader startup	HSE timeout
STM32F03xx4/6	1.612	NA
STM32F05xxx and STM32F030x8 devices	1.612	NA
STM32F04xxx	0.058	NA
STM32F071xx/072xx	0.058	NA
STM32F070x6	HSE connected	200
	HSE not connected	
STM32F070xB	HSE connected	200
	HSE not connected	

Table 146. Bootloader startup timings (ms) for STM32 devices (continued)

Device		Minimum bootloader startup	HSE timeout
STM32F09xxx		2	NA
STM32F030xC		2	NA
STM32F10xxx		1.227	NA
STM32F105xx/107xx	PA9 pin low	1.396	NA
	PA9 pin high	524.376	
STM32F10xxx XL-density		1.227	NA
STM32F2xxxx	V2.x	134	NA
	V3.x	84.59	0.790
STM32F301xx/302x4(6/8)	HSE connected	45	560.5
	HSE not connected	560.8	
STM32F302xB(C)/303xB(C)	HSE connected	43.4	2.236
	HSE not connected	2.36	
STM32F302xD(E)/303xD	HSE connected	7.53	NA
	HSE not connected	146.71	NA
STM32F303x4(6/8)/334xx/328xx		0.155	NA
STM32F318xx		0.182	NA
STM32F358xx		1.542	NA
STM32F373xx	HSE connected	43.4	2.236
	HSE not connected	2.36	
STM32F378xx		1.542	NA
STM32F398xx		1.72	NA
STM32F40xxx/41xxx	V3.x	84.59	0.790
	V9.x	74	96
STM32F401xB(C)		74.5	85
STM32F401xD(E)		74.5	85
STM32F410xx		0.614	NA
STM32F411xx		74.5	85
STM32F412xx		0.614	180
STM32F413xx/423xx		0.642	165
STM32F429xx/439xx	V7.x	82	97
	V9.x	74	97
STM32F446xx		73.61	96
STM32F469xx/479xx		73.68	230
STM32F72xxx/73xxx		17.93	50

Table 146. Bootloader startup timings (ms) for STM32 devices (continued)

Device		Minimum bootloader startup	HSE timeout
STM32F74xxx/75xxx		16.63	50
STM32G03xxx/04xxx		0.390	NA
STM32G07xxx/08xxx		0.390	NA
STM32G0Bxxx/Cxxx		0.390	NA
STM32G4xxxx		0.390	NA
STM32H72xxx/73xxx		53.975	NA
STM32H74xxx/75xxx		53.975	2
STM32H7A3xx/B3xx		53.975	NA
STM32L01xxx/02xxx		0.63	NA
STM32L031xx/041xx		0.62	NA
STM32L05xxx/06xxx		0.22	NA
STM32L07xxx/08xxx	V4.x	0.61	NA
	V11.x	0.71	NA
STM32L1xxx6(8/B)A		0.542	NA
STM32L1xxx6(8/B)		0.542	NA
STM32L1xxxC		0.708	80
STM32L1xxxD		0.708	80
STM32L1xxxE		0.708	200
STM32L43xxx/44xxx		0.3335	100
STM32L45xxx/46xxx		50.93	NA
STM32L47xxx/48xxx	V10.x	LSE connected	55
		LSE not connected	2560
	V9.x	LSE connected	55.40
		LSE not connected	2560.51
STM32L412xx/422xx		0.12	NA
STM32L496xx/4A6xx		76.93	100
STM32L4P5xx /Q5xx		NA	NA
STM32L4Rxx/4Sxx		NA	NA
STM32L552xx/562xx		0.390	NA
STM32WB30xx/35xx/50xx/55xx		0.390	NA
STM32WLE5xx/WL55xx		0.390	NA

68.2 USART connection timing

USART connection timing is the time that the host must wait for between sending the synchronization data (0x7F) and receiving the first acknowledge response (0x79).

Figure 92. USART connection timing description

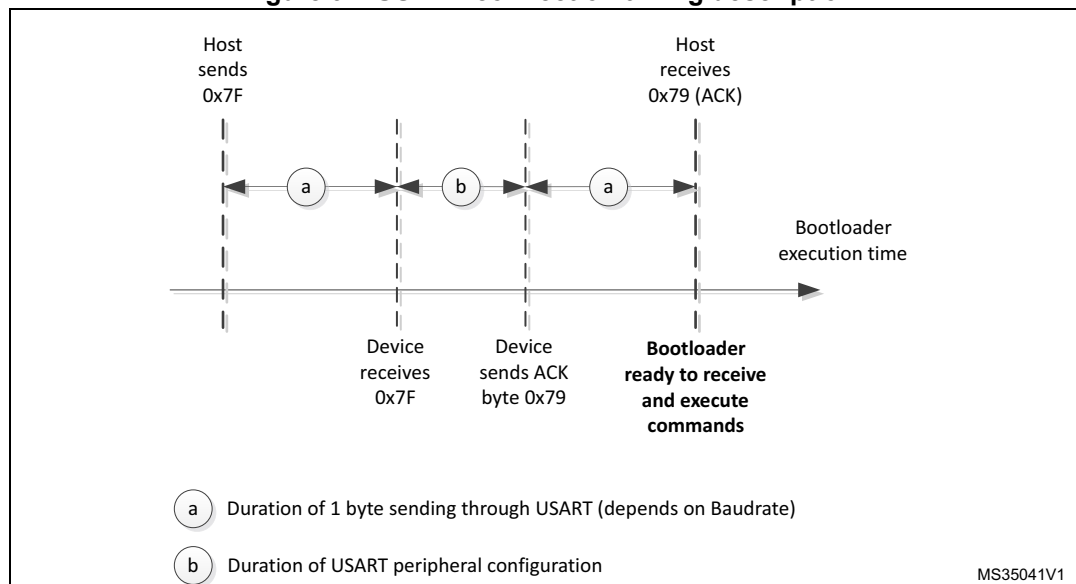

1. Receiving any other character different from 0x7F (or line glitches) will cause bootloader to start communication using a wrong baudrate. Bootloader measures the signal length between rising edge of first 1 bit in 0x7F to the falling edge of the last 1 bit in 0x7F to deduce the baudrate value
2. Bootloader does not re-align the calculated baudrate to standard baudrate values (i.e. 1200, 9600, 115200..).

Note: For STM32F105xx/107xx line devices, PA9 pin (USB_VBUS) is used to detect the USB host connection. The initialization of USB peripheral is performed only if PA9 is high at detection phase which means that a host is connected to the port and delivering 5 V on the USB bus. When PA9 level is high at detection phase, more time is required to initialize and shutdown the USB peripheral. To minimize bootloader detection time when PA9 pin is not used, keep PA9 state low during USART detection phase from the moment the device is reset until a device ACK is sent.

Table 147. USART bootloader minimum timings (ms) for STM32 devices

Device	One USART byte sending	USART configuration	USART connection
STM32F03xx4/6	0.078125	0.0064	0.16265
STM32F05xxx and STM32F030x8 devices	0.078125	0.0095	0.16575
STM32F04xxx	0.078125	0.007	0.16325
STM32F071xx/072xx	0.078125	0.007	0.16325
STM32F070x6	0.078125	0.014	0.17
STM32F070xB	0.078125	0.08	0.23
STM32F09xxx	0.078125	0.07	0.22
STM32F030xC	0.078125	0.07	0.22

Table 147. USART bootloader minimum timings (ms) for STM32 devices (continued)

Device		One USART byte sending	USART configuration	USART connection
STM32F10xxx		0.078125	0.002	0.15825
STM32F105xx/107xx	PA9 pin low	0.078125	0.007	0.16325
	PA9 pin High		105	105.15625
STM32F10xxx XL-density		0.078125	0.006	0.16225
STM32F2xxxx	V2.x	0.078125	0.009	0.16525
	V3.x			
STM32F301xx/302x4(6/8)	HSE connected	0.078125	0.002	0.15825
	HSE not connected			
STM32F302xB(C)/303xB(C)	HSE connected	0.078125	0.002	0.15825
	HSE not connected			
STM32F302xD(E)/303xD		0.078125	0.002	0.15885
STM32F303x4(6/8)/334xx/328xx		0.078125	0.002	0.15825
STM32F318xx		0.078125	0.002	0.15825
STM32F358xx		0.15625	0.001	0.3135
STM32F373xx	HSE connected	0.078125	0.002	0.15825
	HSE not connected			
STM32F378xx		0.15625	0.001	0.3135
STM32F398xx		0.078125	0.002	0.15885
STM32F40xxx/41xxx	V3.x	0.078125	0.009	0.16525
	V9.x		0.0035	0.15975
STM32F401xB(C)		0.078125	0.00326	0.15951
STM32F401xD(E)		0.078125	0.00326	0.15951
STM32F410xx		0.078125	0.002	0.158
STM32F411xx		0.078125	0.00326	0.15951
STM32F412xx		0.078125	0.002	0.158
STM32F413xx/423xx		0.078125	0.002	0.158
STM32F429xx/439xx	V7.x	0.078125	0.007	0.16325
	V9.x		0.00326	0.15951
STM32F446xx		0.078125	0.004	0.16
STM32F469xx/479xx		0.078125	0.003	0.159
STM32F72xxx/73xxx		0.078125	0.070	0.22
STM32F74xxx/75xxx		0.078125	0.065	0.22
STM32G03xxx/04xxx		0.078125	0.01	0.11
STM32G07xxx/08xxx		0.078125	0.01	0.11

Table 147. USART bootloader minimum timings (ms) for STM32 devices (continued)

Device	One USART byte sending	USART configuration	USART connection
STM32G0Bxxx/Cxxx	0.078125	0.01	0.11
STM32G4xxxx	0.078125	0.003	0.159
STM32H72xxx/73xxx	0.078125	0.072	0.22825
STM32H74xxx/75xxx	0.078125	0.072	0.22825
STM32H7A3xx/B3xx	0.078125	0.072	0.22825
STM32L01xxx/02xxx	0.078125	0.016	0.17
STM32L031xx/041xx	0.078125	0.018	0.174
STM32L05xxx/06xxx	0.078125	0.018	0.17425
STM32L07xxx/08xxx	V4.x	0.078125	0.173
	V11.x	0.078125	0.158
STM32L1xxx6(8/B)A	0.078125	0.008	0.16425
STM32L1xxx6(8/B)	0.078125	0.008	0.16425
STM32L1xxxC	0.078125	0.008	0.16425
STM32L1xxxD	0.078125	0.008	0.16425
STM32L1xxxE	0.078125	0.008	0.16425
STM32L412xx/422xx	0.078125	0.005	0.2
STM32L43xxx/44xxx	0.078125	0.003	0.159
STM32L45xxx/46xxx	0.078125	0.07	0.22
STM32L47xxx/48xxx	V10.x	0.078125	0.159
	V9.x	0.078125	0.159
STM32L496xx/4A6xx	0.078125	0.003	0.159
STM32L4Rxx/4Sxx	NA	NA	NA
STM32L4P5xx/4Q5xx	NA	NA	NA
STM32L552xx/562xx	0.078125	0.01	0.11
STM32WB30xx/35xx/50xx/55xx	0.078125	0.003	0.159
STM32WLE5xx/WL55xx	0.078125	0.001	0.110

68.3 USB connection timing

USB connection timing is the time that the host must wait for between plugging the USB cable and establishing a correct connection with the device. This timing includes enumeration and DFU components configuration. USB connection depends on the host.

Figure 93. USB connection timing description

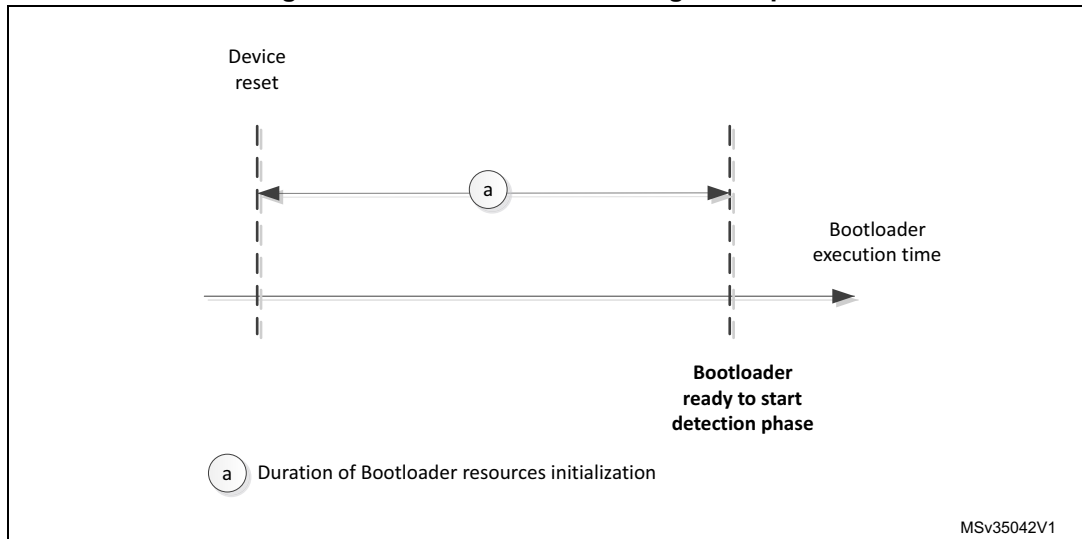

Note: For STM32F105xx/107xx devices, if the external HSE crystal frequency is different from 25 MHz (14.7456 MHz or 8 MHz), the device performs several unsuccessful enumerations (with connect / disconnect sequences) before being able to establish a correct connection with the host. This is due to the HSE automatic detection mechanism based on Start Of Frame (SOF) detection.

Table 148. USB bootloader minimum timings (ms) for STM32 devices

Device		USB connection
STM32F04xxx		350
STM32F070x6		TBD
STM32F070xB		320
STM32F105xx/107xx	HSE = 25 MHz	460
	HSE = 14.7465 MHz	4500
	HSE = 8 MHz	13700
STM32F2xxxx		270
STM32F301xx/302x4(6/8)		300
STM32F302xB(C)/303xB(C)		300
STM32F302xD(E)/303xD		100
STM32F373xx		300
STM32F40xxx/41xxx	V3.x	270
	V9.x	250
STM32F401xB(C)		250
STM32F401xD(E)		250
STM32F411xx		250
STM32F412xx		380
STM32F413xx/423xx		350

Table 148. USB bootloader minimum timings (ms) for STM32 devices (continued)

Device		USB connection
STM32F429xx/439xx	V7.x	250
	V9.x	
STM32F446xx		200
STM32F469xx/479xx		270
STM32F72xxx/73xxx		320
STM32F74xxx/75xxx		230
STM32G0B1xx/C1xx		300
STM32G4xxxx		300
STM32H72xxx/73xxx		53.9764
STM32H74xxx/75xxx		53.9764
STM32H7A3xx/B3xx		53.9764
STM32L07xxx/08xxx		140
STM32L1xxxC		849
STM32L1xxxD		849
STM32L412xx/422xx		820
STM32L43xxx/44xxx		820
STM32L45xxx/46xxx		330
STM32L47xxx/48xxx	V10.x	300
	V9.x	
STM32L496xx/4A6xx		430
STM32L4P5xx/4Q5xx		NA
STM32L4Rxx/4Sxx		NA
STM32L552xx/L562xx		300
STM32WB30xx/35xx/50xx/55xx		300

68.4 I2C connection timing

I2C connection timing is the time that the host must wait for between sending I2C device address and sending command code. This timing includes I2C line stretching duration.

Figure 94. I2C connection timing description

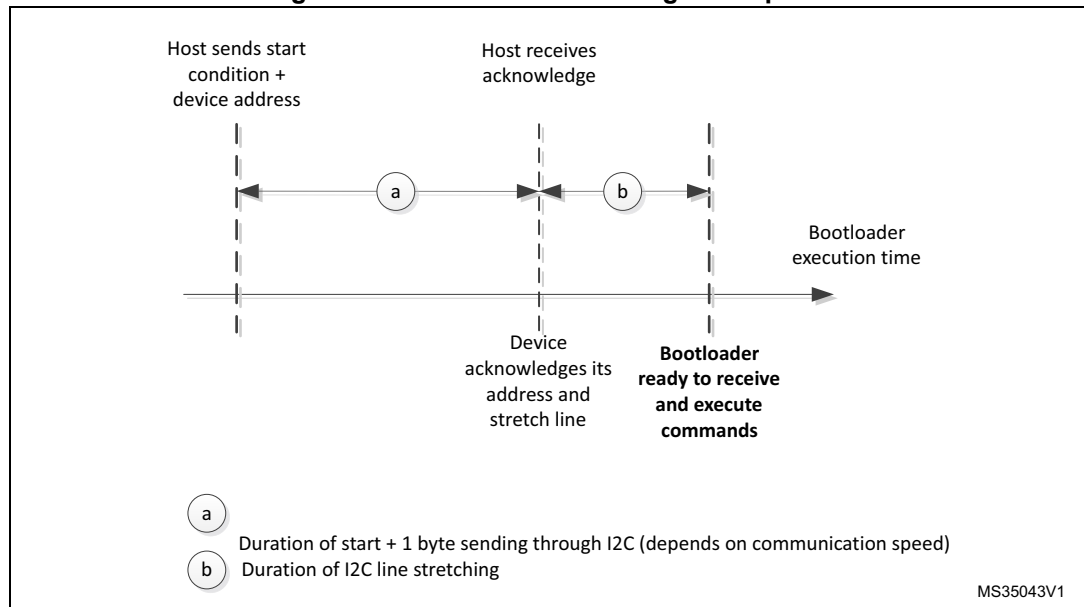

Note: For I2C communication, a timeout mechanism is implemented and it must be respected to execute bootloader commands correctly. This timeout is implemented between two I2C frames in the same command (eg: for Write memory command a timeout is inserted between command sending frame and address memory sending frame). Also the same timeout period is inserted between two successive data receptions or transmissions in the same I2C frame. If the timeout period is elapsed a system reset is generated to avoid bootloader crash.

In erase memory command and read-out unprotect command, the duration of the operation must be taken into consideration when implementing the host side. After sending the code of pages to be erased, the host must wait until the bootloader device performs page erasing to complete the remaining steps of erase command.

Table 149. I2C bootloader minimum timings (ms) for STM32 devices

Device	Start condition + one I2C byte sending	I2C line stretching	I2C connection	I2C timeout
STM32F04xxx	0.0225	0.0025	0.0250	1000
STM32F070x6	0.0225	0.0025	0.0245	1000
STM32F070xB	0.0225	0.0025	0.0245	1000
STM32F071xx/072xx	0.0225	0.0025	0.0250	1000
STM32F09xxx	0.0225	0.0025	0.0245	1000
STM32F030xC	0.0225	0.0025	0.0250	1000
STM32F303x4(6/8)/334xx/328xx	0.0225	0.0027	0.0252	1000

Table 149. I2C bootloader minimum timings (ms) for STM32 devices (continued)

Device	Start condition + one I2C byte sending	I2C line stretching	I2C connection	I2C timeout	
STM32F318xx	0.0225	0.0027	0.0252	1000	
STM32F358xx	0.0225	0.0055	0.0280	10	
STM32F378xx	0.0225	0.0055	0.0280	10	
STM32F398xx	0.0225	0.0020	0.0245	1500	
STM32F40xxx/41xxx	0.0225	0.0022	0.0247	1000	
STM32F401xB(C)	0.0225	0.0022	0.0247	1000	
STM32F401xD(E)	0.0225	0.0022	0.0247	1000	
STM32F410xx	0.0225	0.0020	0.0245	1000	
STM32F411xx	0.0225	0.0022	0.0247	1000	
STM32F412xx	0.0225	0.0020	0.0245	1000	
STM32F413xx/423xx	0.0225	0.0020	0.0245	1000	
STM32F42xxx/43xxx	V7.x	0.0225	0.0033	0.0258	1000
	V9.x	0.0225	0.0022	0.0247	1000
STM32F446xx	0.0225	0.0020	0.0245	1000	
STM32F469xx/479xx	0.0225	0.0020	0.0245	1000	
STM32F72xxx/73xxx	0.0225	0.0020	0.0245	1000	
STM32F74xxx/75xxx	0.0225	0.0020	0.0245	500	
STM32G03xxx/04xxx	0.0225	0.0020	0.0245	1000	
STM32G07xxx/08xxx	0.0225	0.0020	0.0245	1000	
STM32G0Bxx/Cxx	0.0225	0.0020	0.0245	1000	
STM32G4xxxx	0.0225	0.0020	0.0245	1000	
STM32H72xxx/73xxx	0.0225	0.05	0.0745	1000	
STM32H74xxx/75xxx	0.0225	0.05	0.0725	1000	
STM32H7A3xx/7B3xx	0.0225	0.05	0.0745	1000	
STM32L07xxx/08xxx	0.0225	0.0020	0.0245	1000	
STM32L412xx/422xx	0.0225	0.0020	0.0245	1000	
STM32L43xxx/44xxx	0.0225	0.0020	0.0245	1000	
STM32L45xxx/46xxx	0.0225	0.0020	0.0245	1000	
STM32L47xxx/48xxx	V10.x	0.0225	0.0020	0.0245	1000
	V9.x	0.0225	0.0020	0.0245	1000
STM32L496xx/4A6xx	0.0225	0.0020	0.0245	1000	
STM32L4P5xx/4Q5xx	NA	NA	NA	NA	
STM32L4Rxx/4Sxx	NA	NA	NA	NA	

Table 149. I2C bootloader minimum timings (ms) for STM32 devices (continued)

Device	Start condition + one I2C byte sending	I2C line stretching	I2C connection	I2C timeout
STM32L552xx/L562xx	0.0225	0.0020	0.0245	1000
STM32WB30xx/35xx/50xx/55xx	0.0225	0.0020	0.0245	1000

68.5 SPI connection timing

SPI connection timing is the time that the host must wait for between sending the synchronization data (0xA5) and receiving the first acknowledge response (0x79).

Figure 95. SPI connection timing description

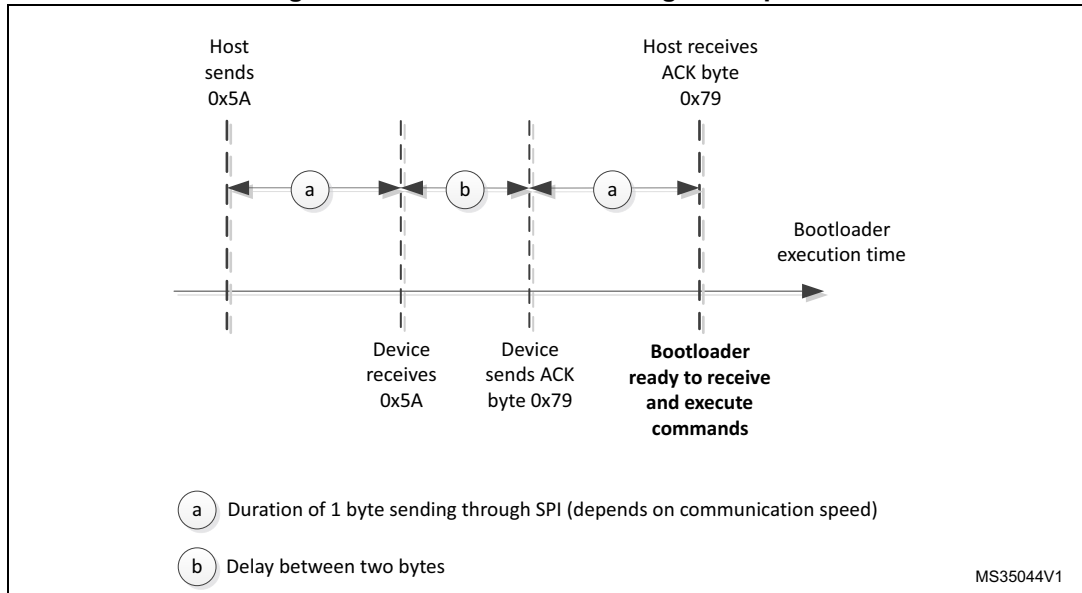

Table 150. SPI bootloader minimum timings (ms) for STM32 devices

Device	One SPI byte sending	Delay between two bytes	SPI connection
All products	0.001	0.008	0.01

Appendix A Example of function to use the “ExitSecureMemory” function

```

/**
*****
****
* @file    main.c
*****
****
*/

/* Includes -----
---*/
#include "main.h"

/* Private function prototypes -----
---*/
static void ConfigClock(void);

void JUMP_WITHOUT_PARAM(uint32_t jump_address);
void JUMP_WITH_PARAM(uint32_t jump_address, uint32_t magic, uint32_t
applicationVectorAddress);

/* Private functions -----
---*/

/**
* @brief  Main program
* @param  None
* @retval None
*/
int main(void)
{
    ConfigClock();

    uint32_t application_address           = 0x08000800;
    uint32_t exit_secure_memory_address   = 0x1FFF1E00;
    uint32_t magic_number                  = 0x08192A3C;
    uint32_t exit_with_magic_number       = 0x0;

    if (exit_with_magic_number)
    {
        JUMP_WITH_PARAM(exit_secure_memory_address, magic_number,
application_address);
    }
}

```

```
else
{
    JUMP_WITHOUT_PARAM(exit_secure_memory_address);
}
}

/**
 * @brief ConfigClock
 * @param None
 * @retval None
 */
static void ConfigClock(void)
{
    /* Will be developed as per the template of the needed project */
}

/**
 * @brief JUMP_WITHOUT_PARAM
 * @param jump_address
 * @retval None
 */
void JUMP_WITHOUT_PARAM(uint32_t jump_address)
{
    asm ("LDR R1, [R0]"); // jump_address
    asm ("LDR R2, [R0,#4]");
    asm ("MOV SP, R1");
    asm ("BX R2");
}

/**
 * @brief JUMP_WITH_PARAM
 * @param jump_address, magic, applicationVectorAddress
 * @retval None
 */
void JUMP_WITH_PARAM(uint32_t jump_address, uint32_t magic, uint32_t
applicationVectorAddress)
{
    asm ("MOV R3, R0"); // jump_address
    asm ("LDR R0, [R3]");
    asm ("MOV SP, R0");
    asm ("LDR R0, [R3,#4]");
    asm ("BX R0");
}
```

```
/****** (C) COPYRIGHT STMicroelectronics *****END OF  
FILE*****/
```

69 Revision history

Table 151. Document revision history

Date	Revision	Changes
22-Oct-2007	1	Initial release.
22-Jan-2008	2	All STM32 in production (rev. B and rev. Z) include the bootloader described in this application note. Modified: Section 3.1: Bootloader activation and Section 1.4: Bootloader code sequence . Added: Section 1.3: Hardware requirements , Section 1.5: Choosing the USART baud rate , Section 1.6: Using the bootloader and Section: Note 2 linked to Get, Get Version & Read Protection Status and Get ID commands in Table 3: Bootloader commands , Note 3 added. Notion of “permanent” (Permanent Write Unprotect/Readout Protect/Unprotect) removed from document. Small text changes. Bootloader version upgraded to 2.0.
26-May-2008	3	Small text changes. RAM and System memory added to Table : The system clock is derived from the embedded internal high-speed RC, no external quartz is required for the bootloader execution . Section 1.6: Using the bootloader on page 8 removed. Erase modified, Note 3 modified and Note 1 added in Table 3: Bootloader commands on page 9 . Byte 3: on page 11 modified. Byte 2: on page 13 modified. Byte 2:, Bytes 3-4: and Byte 5: on page 15 modified, Note 3 modified. Byte 8: on page 18 modified. Notes added to Section 2.5: Go command on page 18 . Figure 11: Go command: device side on page 20 modified. Note added in Section 2.6: Write Memory command on page 21 . Byte 8: on page 24 modified. Figure 14: Erase Memory command: host side and Figure 15: Erase Memory command: device side modified. Byte 3: on page 26 modified. Table 3: Bootloader commands on page 9 . Note modified and note added in Section 2.8: Write Protect command on page 27 . Figure 16: Write Protect command: host side , Figure 17: Write Protect command: device side , Figure 19: Write Unprotect command: device side , Figure 21: Readout Protect command: device side and Figure 23: Readout Unprotect command: device side modified.
29-Jan-2009	4	This application note also applies to the STM32F102xx microcontrollers. Bootloader version updated to V2.2 (see Table 4: Bootloader versions).

Table 151. Document revision history (continued)

Date	Revision	Changes
19-Nov-2009	5	<p>IWDG added to Table : The system clock is derived from the embedded internal high-speed RC, no external quartz is required for the bootloader execution. Note added.</p> <p>BL changed bootloader in the entire document.</p> <p>Go command description modified in Table : The system clock is derived from the embedded internal high-speed RC, no external quartz is required for the bootloader execution.</p> <p>Number of bytes awaited by the bootloader corrected in Section 2.4: Read Memory command.</p> <p>Note modified below Figure 10: Go command: host side.</p> <p>Note removed in Section 2.5: Go command and note added.</p> <p>Start RAM address specified and note added in Section 2.6: Write Memory command.</p> <p>All options are erased when a Write Memory command is issued to the Option byte area.</p> <p>Figure 11: Go command: device side modified.</p> <p>Figure 13: Write Memory command: device side modified.</p> <p>Note added and bytes 3 and 4 sent by the host modified in Section 2.7: Erase Memory command.</p> <p>Note added to Section 2.8: Write Protect command.</p>
09-Mar-2010	6	<p>Application note restructured. Value line and connectivity line device bootloader added (Replaces AN2662).</p> <p>Introduction changed. Glossary added.</p>
20-Apr-2010	7	<p>Related documents: added XL-density line datasheets and programming manual.</p> <p>Glossary: added XL-density line devices.</p> <p>Table 3: added information for XL-density line devices.</p> <p>Section 4.1: Bootloader configuration: updated first sentence.</p> <p>Section 5.1: Bootloader configuration: updated first sentence.</p> <p>Added Section 6: STM32F10xxx XL-density devices bootloader.</p> <p>Table 65: added information for XL-density line devices.</p>
08-Oct-2010	8	<p>Added information for high-density value line devices in Table 3 and Table 65.</p>
14-Oct-2010	9	<p>Removed references to obsolete devices.</p>
26-Nov-2010	10	<p>Added information on ultralow power devices.</p>
13-Apr-2011	11	<p>Added information related to STM32F205/215xx and STM32F207/217xx devices.</p> <p>Added Section 32: Bootloader timing</p>
06-Jun-2011	12	<p>Updated:</p> <ul style="list-style-type: none"> – Table 12: STM32L1xxx6(8/B) bootloader versions – Table 17: STM32F2xxx configuration in System memory boot mode – Table 18: STM32F2xxx bootloader V2.x versions – Table 20: STM32F2xxx bootloader V3.x versions
28-Nov-2011	13	<p>Added information related to STM32F405/415xx and STM32F407/417xx bootloader, and STM32F105xx/107xx bootloader V2.1.</p> <p>Added value line devices in Section 4: STM32F10xxx devices bootloader title and overview.</p>

Table 151. Document revision history (continued)

Date	Revision	Changes
30-Jul-2012	14	<p>Added information related to STM32F051x6/STM32F051x8 and to High-density ultralow power STM32L151xx, STM32L152xx bootloader.</p> <p>Added case of BOOT1 bit in Section 3.1: Bootloader activation.</p> <p>Updated Connectivity line, High-density ultralow power line, STM32F2xx and STM32F4xx in Table 3: Embedded bootloaders.</p> <p>Added bootloader version V2.2 in Table 8: STM32F105xx/107xx bootloader versions.</p> <p>Added bootloader V2.2 in Section 5.3.1: How to identify STM32F105xx/107xx bootloader versions.</p> <p>Added note related to DFU interface below Table 15: STM32L1xxxx high-density configuration in System memory boot mode. Added V4.2 bootloader know limitations and updated description, and added V4.5 bootloader in Table 16: STM32L1xxxx high-density bootloader versions.</p> <p>Added note related to DFU interface below Table 19: STM32F2xxxx configuration in System memory boot mode. Added V3.2 bootloader know limitations, and added V3.3 bootloader in Table 20: STM32F2xxxx bootloader V3.x versions. Updated STM32F2xx and STM32F4xx system memory end address in Table 21: STM32F40xxx/41xxx configuration in System memory boot mode.</p> <p>Added note related to DFU interface below Table 21: STM32F40xxx/41xxx configuration in System memory boot mode. Added V3.0 bootloader know limitations, and added V3.1 bootloader in Table 22: STM32F40xxx/41xxx bootloader V3.x version.</p> <p>Added bootloader V2.1 know limitations in Table 26: STM32F051xx bootloader versions.</p> <p>Updated STM32F051x6/x8 system memory end address in Table 65: Bootloader device-dependent parameters.</p> <p>Added Table 75: USART bootloader timings for high-density ultralow power devices, and Table 78: USART bootloader timings for STM32F051xx devices.</p> <p>Added Table 88: USB minimum timings for high-density ultralow power devices.</p>
24-Jan-2013	15	<p>Updated generic product names throughout the document (see Glossary).</p> <p>Added the following new sections:</p> <ul style="list-style-type: none"> – Section 8: STM32L1xxx devices bootloader. – Section 13: STM32F031xx devices bootloader. – Section 14: STM32F373xx devices bootloader. – Section 15: STM32F302xB(C)/303xB(C) devices bootloader. – Section 16: STM32F378xx devices bootloader. – Section 17: STM32F358xx devices bootloader. – Section 18: STM32F427xx/437xx devices bootloader. – Section 34.3: I2C bootloader timing characteristics. <p>Updated Section 1: Related documents and Section 2: Glossary.</p> <p>Added Table 79 to Table 85 (USART bootloader timings).</p> <p>Replaced Figure 6 to Figure 16, and Figures 18, 19 and 42.</p> <p>Modified Tables 3, 5, 9, 11, 17, 20, 21, 22 to 13, 27, 29, 31, 33, 35, 37 and 65.</p> <p>Removed “X = 6: one USART is used” in Section 3.3: Hardware connection requirement.</p> <p>Replaced address 0x1FFFF 8002 with address 0x1FFF F802 in Section 12.1: Bootloader configuration.</p> <p>Modified procedure related to execution of the bootloader code in Note: on page 28, in Section 6.2: Bootloader selection and in Section 9.2: Bootloader selection.</p>

Table 151. Document revision history (continued)

Date	Revision	Changes
06-Feb-2013	16	<p>Added information related to I²C throughout the document. Streamlined Table 1: Applicable products and Section 1: Related documents. Modified Table 3: Embedded bootloaders as follows:</p> <ul style="list-style-type: none"> – Replaced "V6.0" with "V1.0" – Replaced "0x1FFFF7A6" with "0x1FFFF796" in row STM32F31xx – Replaced "0x1FFF7FA6" with "0x1FFFF7A6" in row STM32F051xx <p>Updated figures 6, 9 and 11. Added Note in Glossary and Note in Section 3.1: Bootloader activation. Replaced:</p> <ul style="list-style-type: none"> – "1.62 V" with "1.8 V" in tables 17, 19, 19, 22, 21, 27, 37 and 59 – "5 Kbyte" with "4 Kbyte" in row RAM of Table 33 – "127 pages (2 KB each)" with "4 KB (2 pages of 2 KB each)" in rows F3 of Table 65 – "The bootloader ID is programmed in the last two bytes of the device system memory" with "The bootloader ID is programmed in the last byte address - 1 of the device system memory" in Section 3.3: Hardware connection requirement. – "STM32F2xxx devices revision Y" by "STM32F2xxx devices revision X and Y" in Section 10: STM32F2xxx devices bootloader – "Voltage Range 2" with "Voltage Range 1" in tables 11, 15 and 26.
21-May-2013	17	<p>Updated:</p> <ul style="list-style-type: none"> – Introduction – Section 2: Glossary – Section 3.3: Hardware connection requirement – Section 7: STM32L1xxx6(8/B) devices bootloader to include STM32L100 value line – Section 32.2: USART connection timing – Section 34.2: USB bootloader timing characteristics – Section 34.3: I2C bootloader timing characteristics – Table 1: Applicable products – Table 3: Embedded bootloaders – Table 25: STM32F051xx configuration in System memory boot mode – Table 27: STM32F031xx configuration in System memory boot mode – Table 65: Bootloader device-dependent parameters – Figure 17: Bootloader selection for STM32F031xx devices <p>Added Section 19: STM32F429xx/439xx devices bootloader.</p>

Table 151. Document revision history (continued)

Date	Revision	Changes
19-May-2014	18	<p>Add:</p> <ul style="list-style-type: none"> – Figure 1 to Figure 5, Figure 71, Figure 8, Figure 27, Figure 28, Figure 26, from Figure 40 to Figure 91, Figure 95 – Table 4, Table 121, Table 122, from Table 9 to Table 48, from Table 49 to Table 46, from Table 71 to Table 72, from Table to Table 150 – Section 38.4, Section 33.2, Section 68.1, Section 68.5 – Section 5, Section 23, Section 24, Section 22, from Section 17 to Section 60 – note under Figure 1, Figure 2, Figure 3 and Figure 4 <p>Updated:</p> <ul style="list-style-type: none"> – Updated starting from Section 4 to Section 7 and Section 18, Section 33 and Section 33 the chapter structure organized in three subsection: Bootloader configuration, Bootloader selection and Bootloader version. Updated Section 60 and Section 68 – Updated block diagram of Figure 27 and Figure 22. – Fixed I2C address for STM32F429xx/439xx devices in Table 69 – Table 1, Table 2, Table 3, Table 27, Table 115, Table 117, Table 119, Table 31, Table 33, Table 53, Table 145 – from Figure 16, to Figure 30, Figure 10, from Figure 91 to Figure 95 – note on Table 116
29-Jul-2014	19	<p>Updated:</p> <ul style="list-style-type: none"> – notes under Table 2 – Figure 70 and Figure 71 – Section 3: Glossary – replaced any reference to STM32F427xx/437xx with STM32F42xxx/43xxx on Section 33: STM32F42xxx/43xxx devices bootloader – replace any occurrence of 'STM32F072xx' with 'STM32F07xxx' – replace any occurrence of 'STM32F051xx' with 'STM32F051xx and STM32F030x8 devices'. – comment field related to OTG_FS_DP and OTG_FS_DM on Table 27, Table 33, Table 53, Table 121, Table 69, Table 71, Table 15, Table 21, Table 57, Table 59 and Table 63 – comment field related to USB_DM on Table 121. – replace reference to "STM32F429xx/439xx" by "STM32F42xxx/43xxx" on Table 3 – comment field related to SPI2_MOSI, SPI2_MISO, SPI2_SCK and SPI2_NSS pins on Table 71 <p>Added:</p> <ul style="list-style-type: none"> – note under Table 2 – reference to STM32F411 on Table 1, Section 3: Glossary, Table 146, Table 147, Table 148, Table 149 – Section 30: STM32F411xx devices bootloader <p>Removed reference to STM32F427xx/437xx on Table 3, Section 3: Glossary, Table 145, Table 146, Table 147, Table 148</p>
24-Nov-2014	20	<p>Updated:</p> <ul style="list-style-type: none"> – comment in "SPI1_NSS pin" and "SPI2_NSS pin" rows on Table 121 and Table 107 – comment in "SPI1_NSS pin", "SPI2_NSS pin" and "SPI3_NSS pin" rows on Table 57, Table 59 and Table 63 – Figure 1

Table 151. Document revision history (continued)

Date	Revision	Changes
11-Mar-2015	21	Updated: – Table 1 , Table 3 , Table 25 , Table 29 , Table 115 , Table 31 , Table 33 , Table 34 , Table 53 , Table 121 , Table 13 , Table 14 , Table 9 , Table 37 , Table 69 , Table 71 , Table 15 , Table 16 , Table 21 , Table 22 , Table 35 , Table 113 , Table 129 , Table 145 , Table 146 , Table 147 , Table 148 and Table 149 – Figure 79 – Chapter 3: Glossary – Section 4.1 and Section 4.4 Added: – Section 60: STM32L47xxx/48xxx devices bootloader and Section 34: STM32F446xx devices bootloader
09-Jun-2015	22	Added: – Section 9: STM32F070x6 devices bootloader – Section 10: STM32F070xB devices bootloader – Section 12: STM32F09xxx devices bootloader – Section 19: STM32F302xD(E)/303xD(E) devices bootloader – Section 25: STM32F398xx devices bootloader – Section 36: STM32F72xxx/73xxx devices bootloader – Section 60.2: Bootloader V9.x – Notes 1 and 2 on Figure 92 Updated: – Table 1 – Section 3: Glossary – Table 2 – Table 3 – Section 4.4: Bootloader memory management – Table 145 , Table 146 , Table 147 , Table 148 and Table 149
29-Sep-2015	23	Added: – Section 29: STM32F410xx devices bootloader – Section 35: STM32F469xx/479xx devices bootloader – Section 49: STM32L031xx/041xx devices bootloader – Section 51: STM32L07xxx/08xxx devices bootloader Updated: – Table 1 – Section 3: Glossary – Table 3 – Figure 79 , Table 131 , Table 146 , Table 147 , Table 148 , Table 149
02-Nov-2015	24	Updated: – Table 1 , Table 3 , Table 145 , Table 146 , Table 147 , Table 148 , Table 149 – Section 35 Added: – Note on Section 26.2.1 – Section 31

Table 151. Document revision history (continued)

Date	Revision	Changes
01-Dec-2015	25	Updated: – Section 4.1 , Section 51 – Table 145
03-Mar-2016	26	Updated: – Table 1 , Table 3 , Table 66 , Table 110 , Table 112 , Table 145 – Section 3 , Section 51.1.1 , Section 51.2.1 , Section 60 Added: – Section 48 : STM32L01xxx/02xxx devices bootloader – Figure 63 , Figure 65
21-Apr-2016	27	Added: – Section 38 : STM32F76xxx/77xxx devices bootloader , Section 58 : STM32L43xxx/44xxx devices bootloader . – Note on: Section 4.1 : Bootloader activation , Section 8.1 : Bootloader configuration , Section 9.1 : Bootloader configuration , Figure 38 : Dual bank boot implementation for STM32F42xxx/43xxx Bootloader V7.x , Figure 40 : Dual bank boot implementation for STM32F42xxx/43xxx bootloader V9.x Updated: – Table 1 : Applicable products , Table 2 : Bootloader activation patterns , Table 11 : STM32F030xC configuration in system memory boot mode , Table 17 : STM32F070x6 configuration in system memory boot mode , Table 19 : STM32F070xB configuration in system memory boot mode , Table 23 : STM32F09xxx configuration in system memory boot mode , Table 35 : STM32F301xx/302x4(6/8) configuration in system memory boot mode , Table 37 : STM32F302xB(C)/303xB(C) configuration in system memory boot mode , Table 39 : STM32F302xD(E)/303xD(E) configuration in system memory boot mode , Table 47 : STM32F373xx configuration in system memory boot mode , Table 57 : STM32F401xB(C) configuration in system memory boot mode , Table 59 : STM32F401xD(E) configuration in system memory boot mode , Table 63 : STM32F411xx configuration in system memory boot mode , Table 130 : STM32L47xxx/48xxx bootloader V10.x versions , Table 132 : STM32L47xxx/48xxx bootloader V9.x versions , Table 145 : Bootloader device-dependent parameters – Section 3 : Glossary ,

Table 151. Document revision history (continued)

Date	Revision	Changes
05-Sep-2016	28	<p>Updated:</p> <ul style="list-style-type: none"> - <i>Table 1: Applicable products, Table 11: STM32F030xC configuration in system memory boot mode, Table 13: STM32F05xxx and STM32F030x8 devices configuration in system memory boot mode, Table 15: STM32F04xxx configuration in system memory boot mode, Table 17: STM32F070x6 configuration in system memory boot mode, Table 19: STM32F070xB configuration in system memory boot mode, Table 21: STM32F071xx/072xx configuration in system memory boot mode, Table 23: STM32F09xxx configuration in system memory boot mode, Table 27: STM32F105xx/107xx configuration in system memory boot mode, Table 29: STM32F10xxx XL-density configuration in system memory boot mode, Table 31: STM32F2xxxx configuration in system memory boot mode, Table 33: STM32F2xxxx configuration in system memory boot mode, Table 35: STM32F301xx/302x4(6/8) configuration in system memory boot mode, Table 37: STM32F302xB(C)/303xB(C) configuration in system memory boot mode, Table 39: STM32F302xD(E)/303xD(E) configuration in system memory boot mode, Table 41: STM32F303x4(6/8)/334xx/328xx configuration in system memory boot mode, Table 43: STM32F318xx configuration in system memory boot mode, Table 45: STM32F358xx configuration in system memory boot mode, Table 47: STM32F373xx configuration in system memory boot mode, Table 49: STM32F378xx configuration in system memory boot mode, Table 51: STM32F398xx configuration in system memory boot mode, Table 53: STM32F40xxx/41xxx configuration in system memory boot mode, Table 55: STM32F40xxx/41xxx configuration in system memory boot mode, Table 57: STM32F401xB(C) configuration in system memory boot mode, Table 59: STM32F401xD(E) configuration in system memory boot mode, Table 63: STM32F411xx configuration in system memory boot mode, Table 69: STM32F42xxx/43xxx configuration in system memory boot mode, Table 71: STM32F42xxx/43xxx configuration in system memory boot mode, Table 73: STM32F446xx configuration in system memory boot mode, Table 75: STM32F469xx/479xx configuration in system memory boot mode, Table 79: STM32F74xxx/75xxx configuration in system memory boot mode, Table 81: STM32F74xxx/75xxx configuration in system memory boot mode, Table 107: STM32L05xxx/06xxx configuration in system memory boot mode, Table 113: STM32L1xxx6(8/B)A configuration in system memory boot mode, Table 115: STM32L1xxx6(8/B) configuration in system memory boot mode, Table 117: STM32L1xxxC configuration in system memory boot mode, Table 119: STM32L1xxxD configuration in system memory boot mode, Table 121: STM32L1xxxE configuration in system memory boot mode, Table 126: STM32L43xxx/44xxx bootloader versions, Table 129: STM32L47xxx/48xxx configuration in system memory boot mode, Table 145: Bootloader device-dependent parameters</i> - <i>Section 58.1: Bootloader configuration</i> - <i>Figure 24: Bootloader selection for STM32F303x4(6/8)/334xx/328xx, Figure 25: Bootloader selection for STM32F318xx, Figure 27: Bootloader selection for STM32F373xx devices, Figure 28: Bootloader selection for STM32F378xx devices, Figure 31: Bootloader V9.x selection for STM32F40xxx/41xxx, Figure 34: Bootloader V11.x selection for STM32F410xx, Figure 36: Bootloader V9.x selection for STM32F412xx, Figure 44: Bootloader V9.x selection for STM32F469xx/479xx, Figure 49: Bootloader V9.x selection for STM32F76xxx/77xxx, Figure 66: Bootloader V11.x selection for STM32L07xxx/08xxx, Figure 79: Bootloader V10.x selection for STM32L47xxx/48xxx</i>

Table 151. Document revision history (continued)

Date	Revision	Changes
07-Dec-2016	29	<p>Updated:</p> <ul style="list-style-type: none"> – Table 1: Applicable products, Section 3: Glossary, Section 4.1: Bootloader activation, Table 3: Embedded bootloaders, Table 12: STM32F09xxx devices bootloader, Table 14: STM32F105xx/107xx devices bootloader, Table 15: STM32F10xxx XL-density devices bootloader, Table 16: STM32F2xxx devices bootloader, Table 17: STM32F301xx/302x4(6/8) devices bootloader, Table 18: STM32F302xB(C)/303xB(C) devices bootloader, Table 20: STM32F303x4(6/8)/334xx/328xx devices bootloader, Table 22: STM32F358xx devices bootloader, Table 25: STM32F398xx devices bootloader, Table 29: STM32F410xx devices bootloader, Table 32: STM32F413xx/423xx devices bootloader, Table 59: STM32F401xD(E) configuration in system memory boot mode, Section 14.3.1: How to identify STM32F105xx/107xx bootloader versions, Section 28.1: Bootloader configuration, Table 61: STM32F410xx configuration in system memory boot mode, Table 63: STM32F411xx configuration in system memory boot mode, Table 65: STM32F412xx configuration in system memory boot mode, Section 30.1: Bootloader configuration, Table 70: STM32F42xxx/43xxx bootloader V7.x versions, Table 72: STM32F42xxx/43xxx bootloader V9.x versions, Table 83: STM32F76xxx/77xxx configuration in system memory boot mode, Table 84: STM32F76xxx/77xxx bootloader V9.x versions, Table 104: STM32L01xxx/02xxx bootloader versions, Table 112: STM32L07xxx/08xxx bootloader V11.x versions, Table 125: STM32L43xxx/44xxx configuration in system memory boot mode, Table 126: STM32L43xxx/44xxx bootloader versions, Table 130: STM32L47xxx/48xxx bootloader V10.x versions, Table 145: Bootloader device-dependent parameters, Table 146: Bootloader startup timings (ms) for STM32 devices, Table 148: USB bootloader minimum timings (ms) for STM32 devices, Table 148: USB bootloader minimum timings (ms) for STM32 devices, Table 149: I2C bootloader minimum timings (ms) for STM32 devices <p>Added:</p> <ul style="list-style-type: none"> – Section 32: STM32F413xx/423xx devices bootloader

Table 151. Document revision history (continued)

Date	Revision	Changes
13-Mar-2017	30	<p>Updated:</p> <ul style="list-style-type: none"> – <i>Table 1: Applicable products, Table 3: Embedded bootloaders, Table 14: STM32F05xxx and STM32F030x8 devices bootloader versions, Table 15: STM32F04xxx configuration in system memory boot mode, Table 16: STM32F04xxx bootloader versions, Table 18: STM32F070x6 bootloader versions, Table 20: STM32F070xB bootloader versions, Table 21: STM32F071xx/072xx configuration in system memory boot mode, Table 22: STM32F071xx/072xx bootloader versions, Table 23: STM32F09xxx configuration in system memory boot mode, Table 24: STM32F09xxx bootloader versions, Table 35: STM32F301xx/302x4(6/8) configuration in system memory boot mode, Table 38: STM32F302xB(C)/303xB(C) bootloader versions, Table 84: STM32F76xxx/77xxx bootloader V9.x versions, Table 103: STM32L01xxx/02xxx configuration in system memory boot mode, Table 126: STM32L43xxx/44xxx bootloader versions, Table 145: Bootloader device-dependent parameters, Table 131: STM32L47xxx/48xxx configuration in system memory boot mode, Table 146: Bootloader startup timings (ms) for STM32 devices, Table 147: USART bootloader minimum timings (ms) for STM32 devices, Table 148: USB bootloader minimum timings (ms) for STM32 devices, Table 149: I2C bootloader minimum timings (ms) for STM32 devices, Table 150: SPI bootloader minimum timings (ms) for STM32 devices</i> – <i>Section 3: Glossary, Section 6.1: Bootloader configuration, Section 14.3.3: USART bootloader Get-Version command returns 0x20 instead of 0x22, RPN reference in Section 58: STM32L43xxx/44xxx devices bootloader and in Section 60: STM32L47xxx/48xxx devices bootloader</i> <p>Added <i>Section 36: STM32F72xxx/73xxx devices bootloader and Section 61: STM32L496xx/4A6xx devices bootloader</i></p>

Table 151. Document revision history (continued)

Date	Revision	Changes
04-Jul-2017	31	<p>Updated:</p> <ul style="list-style-type: none"> – Table 1: Applicable products, Table 2: Bootloader activation patterns, Table 3: Embedded bootloaders, Table 28: STM32F105xx/107xx bootloader versions, Table 33: STM32F2xxxx configuration in system memory boot mode, Table 37: STM32F302xB(C)/303xB(C) configuration in system memory boot mode, Table 45: STM32F358xx configuration in system memory boot mode, Table 47: STM32F373xx configuration in system memory boot mode, Table 49: STM32F378xx configuration in system memory boot mode, Table 55: STM32F40xxx/41xxx configuration in system memory boot mode, Table 57: STM32F401xB(C) configuration in system memory boot mode, Table 59: STM32F401xD(E) configuration in system memory boot mode, Table 63: STM32F411xx configuration in system memory boot mode, Table 69: STM32F42xxx/43xxx configuration in system memory boot mode, Table 73: STM32F446xx configuration in system memory boot mode, Table 75: STM32F469xx/479xx configuration in system memory boot mode, Table 77: STM32F72xxx/73xxx configuration in system memory boot mode, Table 79: STM32F74xxx/75xxx configuration in system memory boot mode, Table 81: STM32F74xxx/75xxx configuration in system memory boot mode, Table 99: STM32H74xxx/75xxx configuration in system memory boot mode, Table 117: STM32L1xxxC configuration in system memory boot mode, Table 119: STM32L1xxxD configuration in system memory boot mode, Table 121: STM32L1xxxE configuration in system memory boot mode, Table 127: STM32L45xxx/46xxx configuration in system memory boot mode, Table 145: Bootloader device-dependent parameters, Table 146: Bootloader startup timings (ms) for STM32 devices, Table 147: USART bootloader minimum timings (ms) for STM32 devices, Table 148: USB bootloader minimum timings (ms) for STM32 devices, Table 149: I2C bootloader minimum timings (ms) for STM32 devices – Introduction, Section 3: Glossary – Figure 75: Bootloader V9.x selection for STM32L43xxx/44xxx <p>Added:</p> <ul style="list-style-type: none"> – Section 46: STM32H74xxx/75xxx devices bootloader, Section 59: STM32L45xxx/46xxx devices bootloader
16-Feb-2018	32	<p>Updated Table 3: Embedded bootloaders, Table 100: STM32H74xxx/75xxx bootloader version, Table 133: STM32L496xx/4A6xx configuration in system memory boot mode, Table 134: STM32L496xx/4A6xx bootloader version, Table 145: Bootloader device-dependent parameters, Table 146: Bootloader startup timings (ms) for STM32 devices, Table 147: USART bootloader minimum timings (ms) for STM32 devices, Table 148: USB bootloader minimum timings (ms) for STM32 devices, Table 149: I2C bootloader minimum timings (ms) for STM32 devices.</p> <p>Added Section 63: STM32L4Rxxx/4Sxxx devices bootloader</p>
07-Aug-2018	33	<p>Updated Note: in Section 8.1: Bootloader configuration, Note: in Section 9.1: Bootloader configuration</p>

Table 151. Document revision history (continued)

Date	Revision	Changes
05-Nov-2018	34	<p>Updated Table 1: Applicable products, Table 54: STM32F40xxx/41xxx bootloader V3.x versions, Table 56: STM32F40xxx/41xxx bootloader V9.x versions, Table 58: STM32F401xB(C) bootloader versions, Table 60: STM32F401xD(E) bootloader versions, Table 62: STM32F410xx bootloader V11.x versions, Table 64: STM32F411xx bootloader versions, Table 66: STM32F412xx bootloader V9.x versions, Table 68: STM32F413xx/423xx bootloader V9.x versions, Table 70: STM32F42xxx/43xxx bootloader V7.x versions, Table 72: STM32F42xxx/43xxx bootloader V9.x versions, Table 74: STM32F446xx bootloader V9.x versions, Table 76: STM32F469xx/479xx bootloader V9.x versions, Table 78: STM32F72xxx/73xxx bootloader V9.x versions, Table 80: STM32F74xxx/75xxx bootloader V7.x versions, Table 82: STM32F74xxx/75xxx bootloader V9.x versions, Table 84: STM32F76xxx/77xxx bootloader V9.x versions, Table 145: Bootloader device-dependent parameters, Table 146: Bootloader startup timings (ms) for STM32 devices, Table 147: USART bootloader minimum timings (ms) for STM32 devices, Table 148: USB bootloader minimum timings (ms) for STM32 devices.</p> <p>Added Section 57: STM32L412xx/422xx devices bootloader</p>
06-Dec-2018	35	<p>Updated Table 1: Applicable products, Section 3: Glossary, Table 146: Bootloader startup timings (ms) for STM32 devices, Table 147: USART bootloader minimum timings (ms) for STM32 devices, Table 149: I2C bootloader minimum timings (ms) for STM32 devices.</p> <p>Added Section 40: STM32G07xxx/08xxx device bootloader</p>
21-Feb-2019	36	<p>Updated Table 1: Applicable products, Section 3: Glossary, Table 3: Embedded bootloaders, Table 145: Bootloader device-dependent parameters, Table 146: Bootloader startup timings (ms) for STM32 devices, Table 147: USART bootloader minimum timings (ms) for STM32 devices, Table 148: USB bootloader minimum timings (ms) for STM32 devices, Table 149: I2C bootloader minimum timings (ms) for STM32 devices.</p> <p>Added Section 65: STM32WB30xx/35xx/50xx/55xx devices bootloader</p>
06-May-2019	37	<p>Updated Table 1: Applicable products, Section 3: Glossary, Table 145: Bootloader device-dependent parameters, Table 146: Bootloader startup timings (ms) for STM32 devices, Table 147: USART bootloader minimum timings (ms) for STM32 devices, Table 148: USB bootloader minimum timings (ms) for STM32 devices, Table 149: I2C bootloader minimum timings (ms) for STM32 devices.</p> <p>Added Section 43: STM32G431xx/441xx devices bootloader, Section 44: STM32G47xxx/48xxx devices bootloader</p>

Table 151. Document revision history (continued)

Date	Revision	Changes
08-Jul-2019	38	<p>Updated:</p> <ul style="list-style-type: none"> – Table 1: Applicable products, Table 2: Bootloader activation patterns, Table 3: Embedded bootloaders, Table 67: STM32F413xx/423xx configuration in system memory boot mode, Table 99: STM32H74xxx/75xxx configuration in system memory boot mode, Table 100: STM32H74xxx/75xxx bootloader version, Table 105: STM32L031xx/041xx configuration in system memory boot mode, Table 126: STM32L43xxx/44xxx bootloader versions, Table 127: STM32L45xxx/46xxx configuration in system memory boot mode, Table 134: STM32L496xx/4A6xx bootloader version, Table 142: STM32WB30xx/35xx/50xx/55xx bootloader versions, Table 145: Bootloader device-dependent parameters, Table 146: Bootloader startup timings (ms) for STM32 devices, Table 147: USART bootloader minimum timings (ms) for STM32 devices, Table 148: USB bootloader minimum timings (ms) for STM32 devices, Table 149: I2C bootloader minimum timings (ms) for STM32 devices – Section 3: Glossary, Section 4.1: Bootloader activation, Section 39.1: Bootloader configuration, Section 43.1: Bootloader configuration – Figure 58: Bootloader V9.x selection for STM32H74xxx/75xxx, Figure 86: Dual bank boot implementation for STM32L4Rxxx/STM32L4Sxxx bootloader V9.x <p>Added Note: in Section 4.2, Note: in Section 13.3, Note: in Section 46.1, Note: in Section 48.1, Section 39: STM32G03xxx/ STM32G04xxx devices bootloader</p>
16-Sep-2019	39	<p>Updated:</p> <ul style="list-style-type: none"> – Table 1: Applicable products, Table 2: Bootloader activation patterns, Table 3: Embedded bootloaders, Table 86: STM32G03xx/04xxx bootloader versions, Table 124: STM32L412xx/422xx bootloader versions, Table 126: STM32L43xxx/44xxx bootloader versions, Table 128: STM32L45xxx/46xxx bootloader versions, Table 130: STM32L47xxx/48xxx bootloader V10.x versions, Table 132: STM32L47xxx/48xxx bootloader V9.x versions, Table 134: STM32L496xx/4A6xx bootloader version, Table 136: STM32L4P5xx/4Q5xx bootloader versions, Table 145: Bootloader device-dependent parameters, Table 146: Bootloader startup timings (ms) for STM32 devices, Table 147: USART bootloader minimum timings (ms) for STM32 devices, Table 148: USB bootloader minimum timings (ms) for STM32 devices, Table 149: I2C bootloader minimum timings (ms) for STM32 devices – Section 3: Glossary, Section 4.2: Bootloader identification <p>Added Figure 56: Dual bank boot implementation for STM32G47xxx/48xxx bootloader V13.x, Section 64: STM32L552xx/STM32L562xx devices bootloader, note in Section 65.3: Bootloader version</p>
03-Oct-2019	40	<p>Updated Table 3: Embedded bootloaders, Table 140: STM32L552xx/562xx bootloader versions, Table 142: STM32WB30xx/35xx/50xx/55xx bootloader versions</p>
25-Oct-2019	41	<p>Updated:</p> <ul style="list-style-type: none"> – Table 78: STM32F72xxx/73xxx bootloader V9.x versions, Table 80: STM32F74xxx/75xxx bootloader V7.x versions, Table 82: STM32F74xxx/75xxx bootloader V9.x versions, Table 84: STM32F76xxx/77xxx bootloader V9.x versions, Table 85: STM32G03xxx/G04xxx configuration in system memory boot mode, Table 100: STM32H74xxx/75xxx bootloader version, Table 136: STM32L4P5xx/4Q5xx bootloader versions, Table 139: STM32L552xx/562xx configuration in system memory boot mode, Table 146: Bootloader startup timings (ms) for STM32 devices, Table 147: USART bootloader minimum timings (ms) for STM32 devices, Table 149: I2C bootloader minimum timings (ms) for STM32 devices – Section 16: STM32F2xxxx devices bootloader

Table 151. Document revision history (continued)

Date	Revision	Changes
05-Dec-2019	42	<p>Updated:</p> <ul style="list-style-type: none"> – Table 1: Applicable products, Table 2: Bootloader activation patterns, Table 3: Embedded bootloaders, Table 145: Bootloader device-dependent parameters, Table 146: Bootloader startup timings (ms) for STM32 devices, Table 147: USART bootloader minimum timings (ms) for STM32 devices, Table 148: USB bootloader minimum timings (ms) for STM32 devices, Table 149: I2C bootloader minimum timings (ms) for STM32 devices – Section 3: Glossary <p>Added: Section 47: STM32H7A3xx/B3xx devices bootloader, Section 62: STM32L4P5xx/4Q5xx devices bootloader, Section 66: STM32WLE5xx/55xx devices bootloader</p>
04-Jun-2020	43	<p>Updated:</p> <ul style="list-style-type: none"> – Table 1: Applicable products, Table 2: Bootloader activation patterns, Table 3: Embedded bootloaders, Table 93: STM32G431xx/441xx configuration in system memory boot mode, Table 95: STM32G47xxx/48xxx configuration in system memory boot mode, Table 96: STM32G47xxx/48xxx bootloader version, Table 100: STM32H74xxx/75xxx bootloader version, Table 102: STM32H7A3xx/7B3xx bootloader version, Table 136: STM32L4P5xx/4Q5xx bootloader versions, Table 139: STM32L552xx/562xx configuration in system memory boot mode, Table 140: STM32L552xx/562xx bootloader versions, Table 141: STM32WB30xx/35xx/50xx/55xx configuration in system memory boot mode, Table 145: Bootloader device-dependent parameters – Section 3: Glossary, Section 37: STM32F74xxx/75xxx devices bootloader, Section 39.1: Bootloader configuration, Section 40.1: Bootloader configuration, Section 43.1: Bootloader configuration, Section 44.1: Bootloader configuration, Section 46.1: Bootloader configuration <p>Added:</p> <ul style="list-style-type: none"> – Section 4.5: Bootloader UART baudrate detection, Section 4.6: Programming constraints, Section 4.7: ExitSecureMemory feature – Note in: Section 26.1.1: Bootloader configuration, Section 26.2.1: Bootloader configuration, Section 27.1: Bootloader configuration, Section 28.1: Bootloader configuration, Section 30.1: Bootloader configuration, Section 31.1: Bootloader configuration, Section 32.1: Bootloader configuration, Section 33.1.1: Bootloader configuration, Section 33.2.1: Bootloader configuration, Section 34.1: Bootloader configuration, Section 35.1: Bootloader configuration, Section 36.1: Bootloader configuration, Section 37.1.1: Bootloader configuration, Section 37.2.1: Bootloader configuration, Section 38.1: Bootloader configuration – Figure 74: Dual bank boot Implementation for STM32L3x2xx/44xxx bootloader V9.x, Figure 76: Dual bank boot Implementation for STM32L45xxx/46xxx bootloader V9.x, Figure 82: Dual bank boot Implementation for STM32L496xx/4A6xx bootloader V9.x – Appendix A: Example of function to use the “ExitSecureMemory” function <p>Deleted Figure 48. Access to securable memory area from the bootloader for STM32G03xxx/G04xxx, Figure 50. Access to securable memory area from the bootloader for STM32G07xxx/G08xxx, Figure 52. Access to securable memory area, Figure 54. Access to securable memory area</p>

Table 151. Document revision history (continued)

Date	Revision	Changes
29-Jul-2020	44	<p>Introduced STM32H72xxx/73xxx devices, hence added Section 45: STM32H72xxx/73xxx devices bootloader and its subsections.</p> <p>Updated Section 3: Glossary, note in Section 39.1: Bootloader configuration and Section 65.1: Bootloader configuration.</p> <p>Updated Table 1: Applicable products, Table 2: Bootloader activation patterns, Table 3: Embedded bootloaders, Table 8: ExitSecureMemory entry address, Table 95: STM32G47xxx/48xxx configuration in system memory boot mode, Table 102: STM32H7A3xx/7B3xx bootloader version, Table 117: STM32L1xxxC configuration in system memory boot mode, Table 119: STM32L1xxxD configuration in system memory boot mode, Table 121: STM32L1xxxE configuration in system memory boot mode, Table 139: STM32L552xx/562xx configuration in system memory boot mode, Table 145: Bootloader device-dependent parameters, Table 146: Bootloader startup timings (ms) for STM32 devices, Table 147: USART bootloader minimum timings (ms) for STM32 devices, Table 148: USB bootloader minimum timings (ms) for STM32 devices and Table 149: I2C bootloader minimum timings (ms) for STM32 devices.</p> <p>Updated Figure 58: Bootloader V9.x selection for STM32H74xxx/75xxx.</p> <p>Minor text edits across the whole document.</p>
06-Nov-2020	45	<p>Introduced STM32WB30xx, STM32WB35xx, STM32WI55xx in Table 1: Applicable products, Table 3: Embedded bootloaders and in Section 3: Glossary</p> <p>Updated:</p> <ul style="list-style-type: none"> – Table 61: STM32F410xx configuration in system memory boot mode, Table 67: STM32F413xx/423xx configuration in system memory boot mode, Table 73: STM32F446xx configuration in system memory boot mode, Table 75: STM32F469xx/479xx configuration in system memory boot mode, Table 77: STM32F72xxx/73xxx configuration in system memory boot mode, Table 81: STM32F74xxx/75xxx configuration in system memory boot mode, Table 83: STM32F76xxx/77xxx configuration in system memory boot mode, Table 87: STM32G07xxx/8xxx configuration in system memory boot mode, Table 93: STM32G431xx/441xx configuration in system memory boot mode, Table 94: STM32G431xx/441xx bootloader version, Table 95: STM32G47xxx/48xxx configuration in system memory boot mode, Table 99: STM32H74xxx/75xxx configuration in system memory boot mode, Table 100: STM32H74xxx/75xxx bootloader version, Table 101: STM32H7A3xx/7B3xx configuration in system memory boot mode, Table 102: STM32H7A3xx/7B3xx bootloader version, Table 103: STM32L01xxx/02xxx configuration in system memory boot mode, Table 105: STM32L031xx/041xx configuration in system memory boot mode, Table 110: STM32L07xxx/08xxx bootloader versions, Table 111: STM32L07xxx/08xxx configuration in system memory boot mode, Table 123: STM32L412xx/422xx configuration in system memory boot mode, Table 135: STM32L4P5xx/4Q5xx configuration in system memory boot mode, Table 137: STM32L4Rxxx/4Sxxx configuration in system memory boot mode, Table 139: STM32L552xx/562xx configuration in system memory boot mode, Table 141: STM32WB30xx/35xx/50xx/55xx configuration in system memory boot mode, Table 143: STM32WLE5xx/55xx configuration in system memory boot mode, Table 144: STM32WLE5xx/55xx bootloader versions, Table 145: Bootloader device-dependent parameters, Table 146: Bootloader startup timings (ms) for STM32 devices, Table 147: USART bootloader minimum timings (ms) for STM32 devices – title of Table 65: STM32WB30xx/35xx/50xx/55xx devices bootloader, Table 141: STM32WB30xx/35xx/50xx/55xx configuration in system memory boot mode, Table 66: STM32WLE5xx/55xx devices bootloader, Table 143: STM32WLE5xx/55xx configuration in system memory boot mode, Table 90: Bootloader V12.x selection for STM32WLE5xx/55xx, Table 144: STM32WLE5xx/55xx bootloader versions

Table 151. Document revision history (continued)

Date	Revision	Changes
02-Dec-2020	46	<p>Updated:</p> <ul style="list-style-type: none"> – Table 3: Embedded bootloaders, Table 85: STM32G03xxx/G04xxx configuration in system memory boot mode, Table 95: STM32G47xxx/48xxx configuration in system memory boot mode, Table 126: STM32L43xxx/44xxx bootloader versions, Table 128: STM32L45xxx/46xxx bootloader versions <p>Added following notes:</p> <ul style="list-style-type: none"> – Note: on page 283, Note: on page 290, Note: on page 298, Note: on page 310, Note: on page 317
16-Feb-2021	47	<p>Updated:</p> <ul style="list-style-type: none"> – Table 1: Applicable products, Table 3: Embedded bootloaders, Table 8: ExitSecureMemory entry address, Table 84: STM32F76xxx/77xxx bootloader V9.x versions, Table 95: STM32G47xxx/48xxx configuration in system memory boot mode, Table 123: STM32L412xx/422xx configuration in system memory boot mode, Table 125: STM32L43xxx/44xxx configuration in system memory boot mode, Table 127: STM32L45xxx/46xxx configuration in system memory boot mode, Table 131: STM32L47xxx/48xxx configuration in system memory boot mode, Table 133: STM32L496xx/4A6xx configuration in system memory boot mode, Table 135: STM32L4P5xx/4Q5xx configuration in system memory boot mode, Table 137: STM32L4Rxxx/4Sxxx configuration in system memory boot mode, Table 139: STM32L552xx/562xx configuration in system memory boot mode, Table 141: STM32WB30xx/35xx/50xx/55xx configuration in system memory boot mode, Table 145: Bootloader device-dependent parameters, Table 146: Bootloader startup timings (ms) for STM32 devices, Table 147: USART bootloader minimum timings (ms) for STM32 devices, Table 148: USB bootloader minimum timings (ms) for STM32 devices, Table 149: I2C bootloader minimum timings (ms) for STM32 devices – Section 3: Glossary <p>Added Section 41: STM32G0B0xx device bootloader and Section 42: STM32G0B1xx/0C1xx device bootloader</p>

IMPORTANT NOTICE – PLEASE READ CAREFULLY

STMicroelectronics NV and its subsidiaries (“ST”) reserve the right to make changes, corrections, enhancements, modifications, and improvements to ST products and/or to this document at any time without notice. Purchasers should obtain the latest relevant information on ST products before placing orders. ST products are sold pursuant to ST’s terms and conditions of sale in place at the time of order acknowledgement.

Purchasers are solely responsible for the choice, selection, and use of ST products and ST assumes no liability for application assistance or the design of Purchasers’ products.

No license, express or implied, to any intellectual property right is granted by ST herein.

Resale of ST products with provisions different from the information set forth herein shall void any warranty granted by ST for such product.

ST and the ST logo are trademarks of ST. For additional information about ST trademarks, please refer to www.st.com/trademarks. All other product or service names are the property of their respective owners.

Information in this document supersedes and replaces information previously supplied in any prior versions of this document.

© 2021 STMicroelectronics – All rights reserved