

Application Note AN1005 revision 2.1 Simple Measurement of Supercapacitor Parameters

The Problem:

CAP-XX supercapacitors have high capacitance ranging from 0.1 to 2 farad and an ESR (Equivalent Series Resistance) of 25 mΩ to 150 mΩ. The ESR for these supercapacitors must be measured using 4-wire measurement systems such as an LCR bridge. However, these instruments often attempt to measure capacitance & ESR using small AC signals at high frequencies. Supercapacitors are DC components whose capacitance rolls off at frequencies above several hundred Hz, making them unsuitable for measurement by some LCR bridges. Further, LCR bridges are an expensive specialized piece of equipment and so are not always available.

Along with ESR and Capacitance, the other important parameter is leakage current. Cap-XX supercapacitors, when charged, continue to absorb current in the order of 2-10 μA. This current exists due to the chemical nature of the supercapacitors. Leakage current is important only in applications requiring long term charge storage. Leakage current for a supercapacitor is a complex function of voltage, time, temperature and the change in temperature. This application note presents a simple way to measure ESR, Capacitance and leakage current using basic electronic equipment such as a power supply and a multimeter.

1.0 ESR AND C MEASUREMENT

The CAP-XX solution

The diagram below shows the setup used in this application note for measuring ESR and C for Cap-XX supercapacitors.

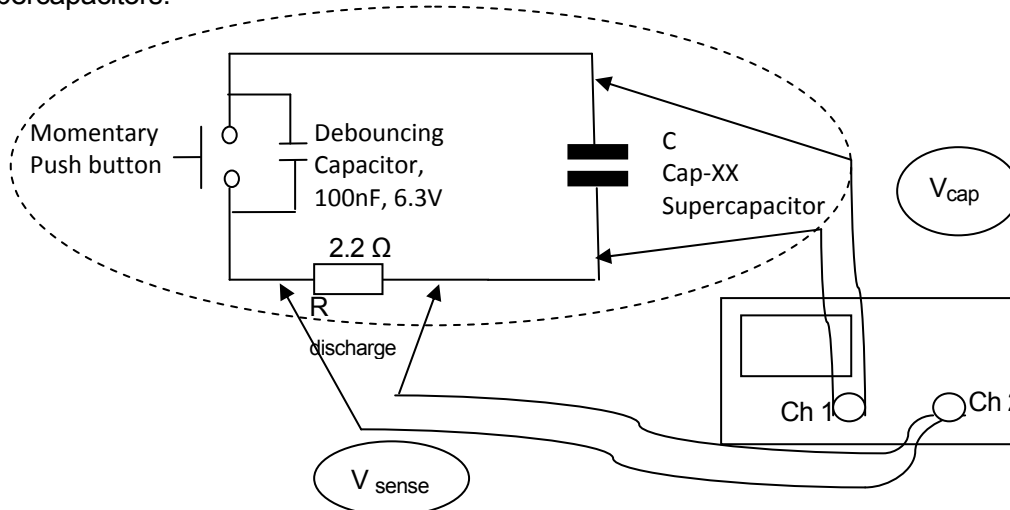

Fig 1: Measurement Setup for C & ESR

A picture of the items circled in Fig 1 is above is shown below in Fig 2. This illustrates how simple the setup is.

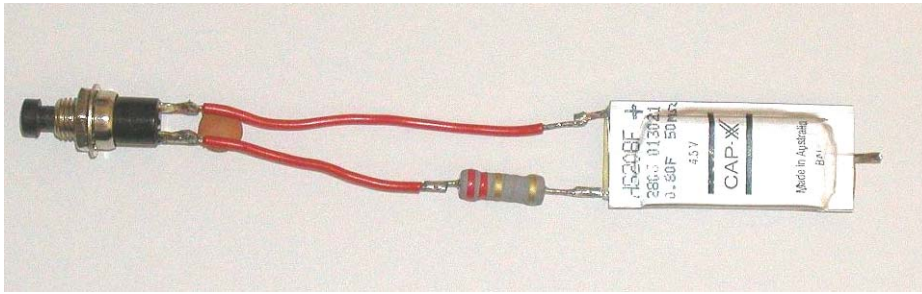

Fig 2: Picture of Supercapacitor Measurement Setup

The items required are:

1. Digital Storage Oscilloscope (DSO) (min. requirements- 2 channels., 20 MHz BW limited, pulse trigger);
2. 2 × Voltage probes for the DSO;
3. DC Power supply (required output voltage: 5.5V max);
4. 2 × alligator clip leads.
5. 2.2 Ω resistor (>3W; desirable tolerance of 0.1%);
6. Momentary action push button (with minimal switch bounce);
7. 0.1 μF capacitor (to debounce the push button action);
8. Cap-XX supercapacitor to be measured.

The capacitance measurement technique is based on the fact that one time constant, ($\tau = R \cdot C$) is the time required to discharge the capacitor voltage to 36.8% of its initial voltage. Hence, for a supercapacitor charged to 4.5V, the voltage should drop to 1.656V and a for a single cell supercapacitor charged to 2.3V capacitor, to 0.8464V after one time constant of discharge. Since the resistor value is known, then $C = \text{time to discharge to 36.8\% of initial voltage} / R$. The ESR drop is measured as the voltage drop from time 0 (when the switch is depressed) to 50μsec later / current. The current is the charge voltage of the supercapacitor/R. Since the supercapacitor capacitance is very large, we can ignore the voltage discharge over 50μsec – this will not have a significant effect on the ESR measurement.

1.1 Capacitance Measurement:

1. Assemble the circuit as shown in figure 1.
2. Set channel 1 (V_{CAP}) on the DSO to 1V/div and DC coupled. To get exact values, use calibrated voltage probes.
3. Set channel 2 (R_{SENSE}) on the DSO to 1V/div and DC coupled. To get exact values, use calibrated voltage probes.
4. Set the time base to 1sec/div.
5. Enable 20 MHz bandwidth limit on all channels and set trigger on channel 2 at around 1.5V.
6. Charge the supercapacitor to its rated voltage using the DC power supply and then disconnect it.

- Press the push button until the capacitor voltage has dropped below 0.5V

Refer to the waveform in Fig 3 for the steps 8 – 11.

- For measuring capacitance, initial voltage, $V_{INIT} = V_{RATED} - \Delta V_{ESR}$. Use the cursor on the oscilloscope to determine this value. In Fig 3, this is 4.36V.
- After one time constant, the capacitor voltage would be, $V(\tau) = V_{INIT} \times 0.368$ Volts. In the example of Fig 3, this = 4.36V x 0.368 = 1.60V.
- Using the cursors, find the time (τ) at which the capacitor voltage = $V(\tau)$. In the example of Fig 3 this = 1.83 secs.
- Equate this time to the product of $R_{DISCHARGE}$ (2.2Ω) and Capacitance and find the capacitance, $\tau = R \times C$;

$$\text{Thus, } C = \frac{\tau}{R} \text{ Farads} = \frac{1.832}{2.2} = 0.833 \text{ Farads.}$$

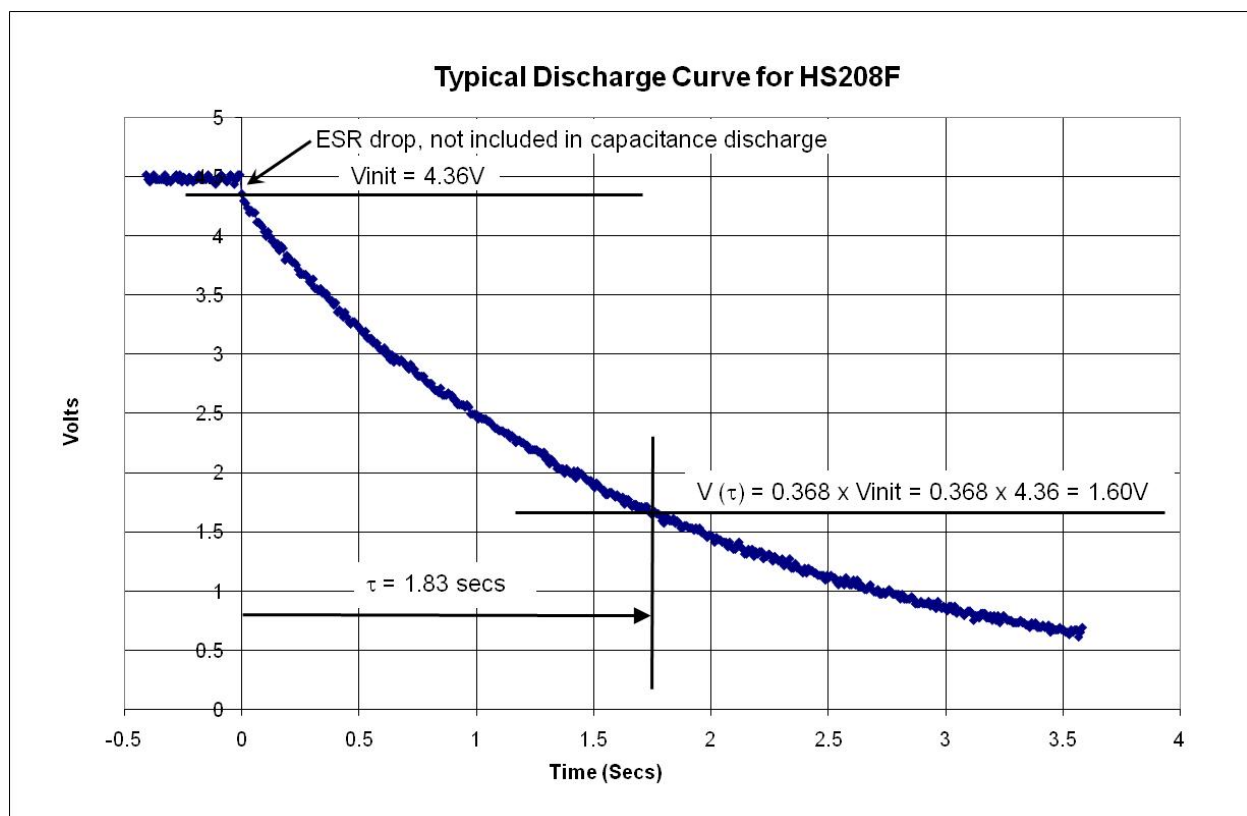

Fig 3: Discharge for Capacitance Measurement

1.2 ESR Measurement

- Assemble the circuit as shown in figure 1.
- Set channel 1 (V_{CAP}) on the DSO to 20mV/div and AC coupled. Measure V_{CAP} using a calibrated voltage probe to get the exact value.
- Set channel 2 (V_{SENSE}) on the DSO to 1V/div and DC coupled. Measure V_{SENSE} using a calibrated voltage probe to get the exact value.
- Set the time base to 10 μ sec/div.

5. Enable 20 MHz bandwidth limit on all channels and set trigger on channel 2 at around 1.5V.
6. Charge the supercapacitor to its rated voltage using the DC power supply and then disconnect it.

Note: Supercapacitor ESR will depend on the “state of charge”, or how long the supercapacitor has been left on charge. ESR will increase slightly (by approx 10%), when the supercapacitor is at full state of charge, i.e. left on voltage for 48hrs. CAP-XX production measurement of ESR is done at full state of charge. If an accurate reading of ESR at full state of charge is required, then at step 6, leave the supercapacitor connected to the DC supply at its rated voltage for 48h hours before disconnecting it.

7. Press and hold the push button momentarily (this will be for more than 50µsec).

Refer to the waveforms in Fig 4 for steps 8 – 10.

8. Using the cursors, find the voltage at 0µsec and 50µsec on channel 1 = V_{CAP} .
9. Using the cursors, also find the voltage on channel 2 = V_{SENSE} (across the $R_{DISCHARGE}$).
10. To calculate ESR:

$$\begin{aligned} \Delta V_{ESR} &= (V_{CAP} @ 0\mu\text{sec}) - (V_{CAP} @ 50\mu\text{sec}) \\ &= 0.828\text{V (from Fig 4)} \end{aligned}$$

$$\begin{aligned} \text{Current} &= \frac{\text{Voltage across } R_{DISCHARGE}}{R_{DISCHARGE}} \\ &= \frac{4.28}{2.2} = 1.93 \text{ Amps} \end{aligned}$$

$$\text{Hence, ESR} = \frac{\Delta V_{ESR}}{\text{Current}} = \frac{0.0824\text{V}}{1.93\text{A}} = 43\text{m}\Omega$$

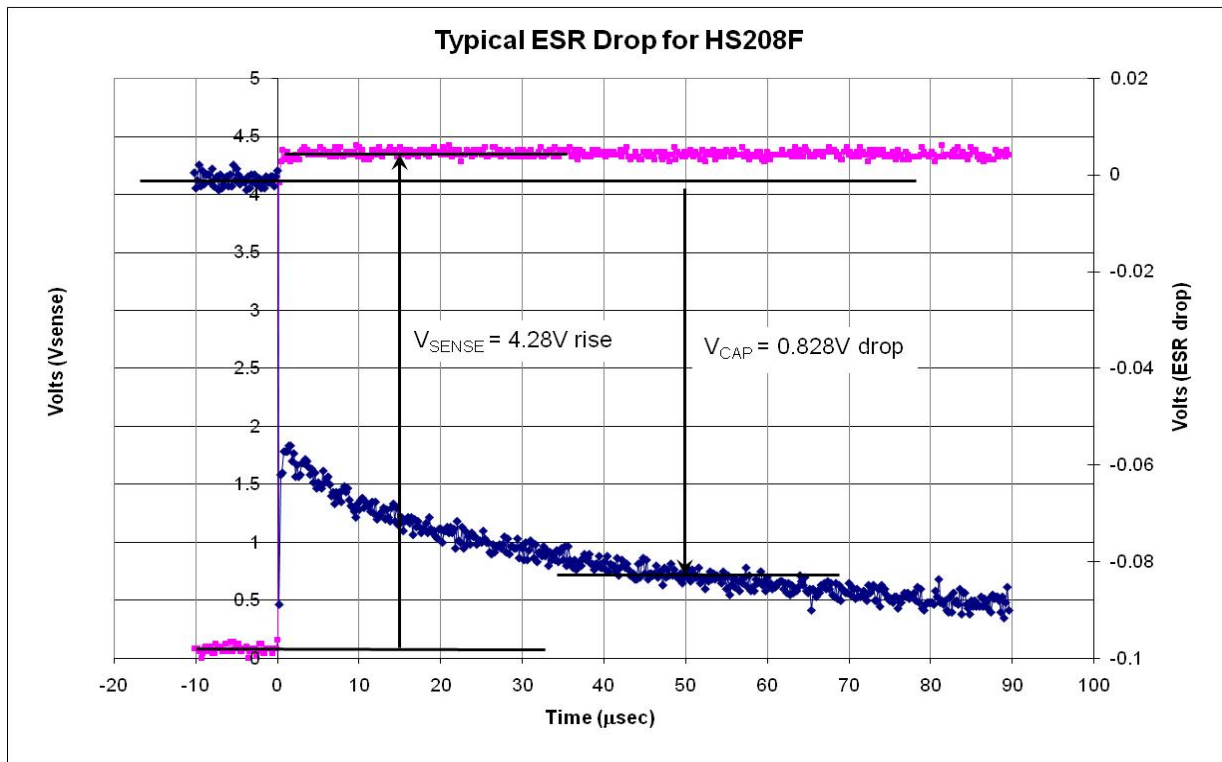

Fig 4: Waveforms for ESR Measurement

Results summary for HS208F:

| RATED ESR | RATED C | MEASURED ESR | MEASURED C |
|-----------|---------|--------------|------------|
| 50mΩ | 0.8F | 43mΩ | 0.83F |

Table 1: Result Summary

2.0 LEAKAGE CURRENT MEASUREMENT

The CAP-XX solution

The diagram below shows the setup used in this application note for measuring leakage current.

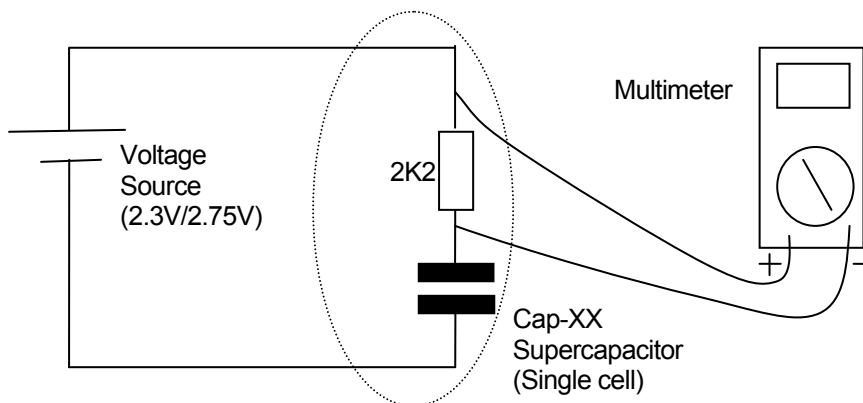

Figure 5: Measurement setup for leakage current

A picture of the items circled in Fig 5 is shown below in Fig 6.

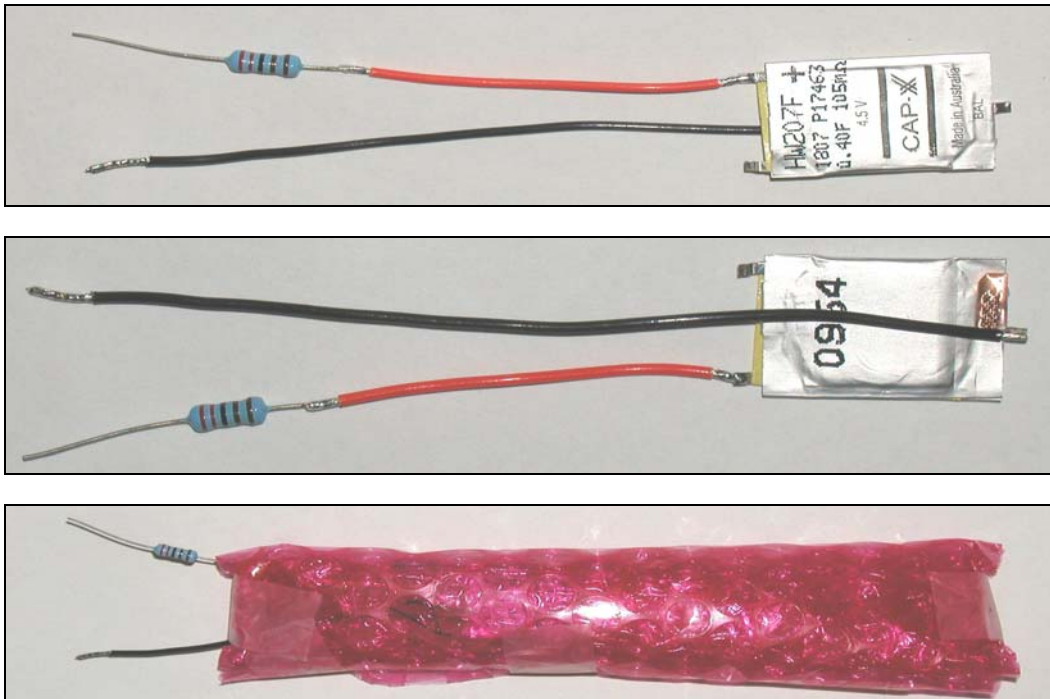

Figure 6: Picture of Supercapacitor Leakage Measurement Setup

Items required:

1. 2K2 resistor (1% tolerance or better);
2. Insulated wires for capacitor terminals;
3. Power supply (with no low frequency noise and output voltage > 2.3V);
4. Multimeter (accurate to 0.1mV);
5. 2 × alligator clip leads;
6. Bubble wrap (~18cm x 16cm) + tape; to wrap the capacitor to ensure minimum temperature fluctuation);

Issues to be considered:

1. Measurements should be done at room temperature with temperature fluctuation < $\pm 1^{\circ}\text{C}$.
2. Leakage measurement must be done for a single cell only.
3. Power supply should have no ripples or low frequency noise over time or temperature.
4. The supercapacitors must not be physically disturbed during the test.

2.1 Leakage Measurement:

1. Assemble the circuit as shown in figure 5.
2. Solder wires and wrap the supercapacitor with the bubble wrap as shown in figure 6.
3. Note:
 - a. to measure the leakage current of the top cell, connect the PSU V+ terminal to the supercapacitor + terminal, and connect PSU V- (or Gnd) terminal to the supercapacitor Bal terminal. This is the connection shown in Fig 6.
 - b. To measure the leakage current of the bottom cell, connect the PSU V+ terminal to the supercapacitor Bal terminal, and connect the PSU V- (or Gnd) terminal to the supercapacitor – terminal.
4. Pre-charge the supercapacitors directly from the power supply (2.3V for G series / 2.75V for H series) for 15 minutes, i.e power supply is directly across the supercapacitor terminals, with the 2K2 resistor not in circuit. The PSU should be current limited (set to ~2A), or if there is no current limit, be able to manage the inrush current which can be up to 20A initially for a few msecs), or alternatively use a 1 Ω current limit resistor between the PSU V+ terminal and the supercapacitor + terminal (for top cell) or supercapacitor Bal terminal (for bottom cell).
5. Disconnect the supercapacitor directly from the power supply and reconnect with the 2K2 resistor in series between the supercapacitor and the PSU, as shown in Fig 6.
6. Wait for 70-75 hours.

- Then measure the voltage across the 2k2 resistor, and divide it by 2200 to get the leakage current. In order to eliminate the effects of any noise, it is recommended to take the average of 10 measurements.

In tests done at Cap-XX, the following measurements were taken:

| Capacitor type | Capacitor Rating | Time (hrs) | Voltage across 2k2 (mV), V_L | Leakage Current (μA) ($V_L/2200$) |
|----------------|---------------------|------------|--------------------------------|--|
| GW201G | 0.3F, 85m Ω | 73 | 2.7 | 1.23 |
| GS206F | 0.55F, 50m Ω | 73 | 4.6 | 2.09 |
| HW207F | 0.4F, 105m Ω | 73 | 1.5 | 0.68 |
| HS208F | 0.8F, 50m Ω | 73 | 5.0 | 2.27 |

Table 2: Result summary

The graph below shows how leakage current decays over time to an equilibrium value. It can be seen that after around 72 hours, absorption current/charge current is no longer significant compared to leakage current. At this time, a reasonable measurement of leakage current can be made.

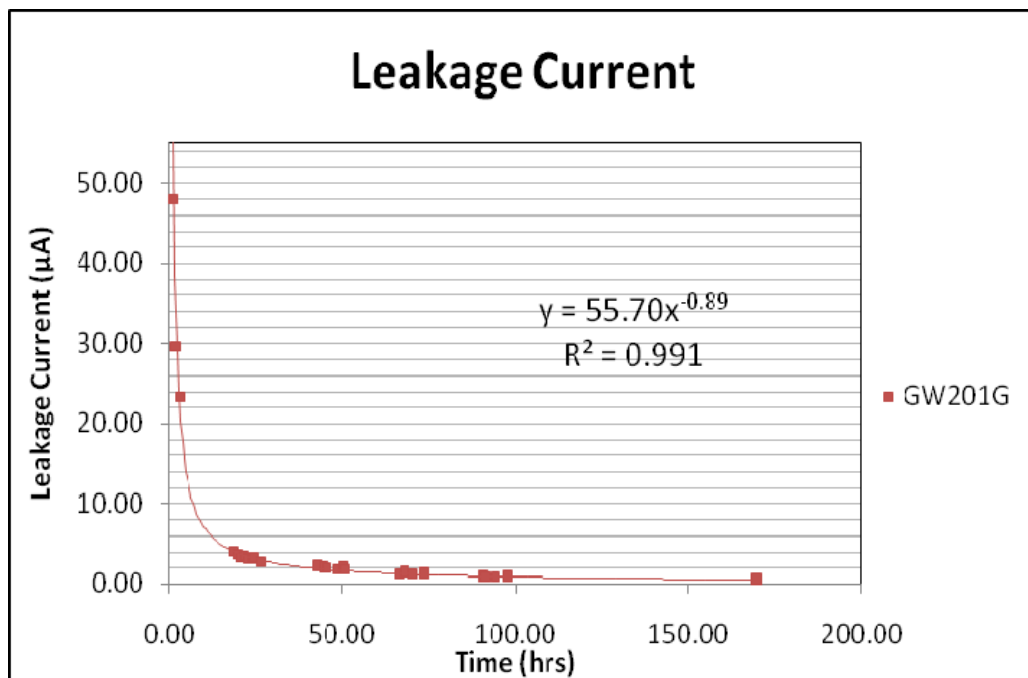

Figure 7: Trend of leakage current

The Benefits:

- Cheap;
- Reliable;
- Components easily available.