

Package information - SOT223

Surface mounted, 4 pin package

Package outline

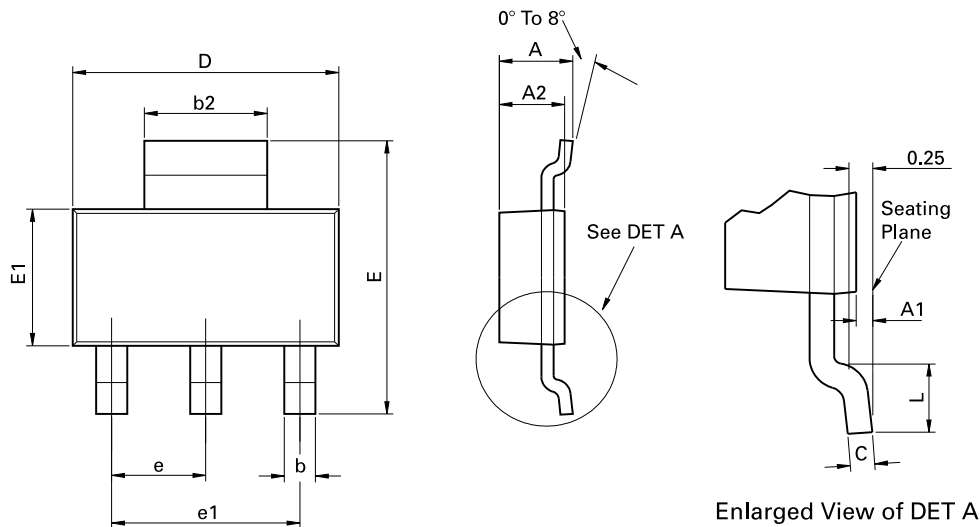

Conforms to JEDEC TO-261 AA Issue B

Dim.	Millimeters		Inches		Dim.	Millimeters		Inches	
	Min.	Max.	Min.	Max.		Min.	Max.	Min.	Max.
A	-	1.80	-	0.071	D	6.30	6.70	0.248	0.264
A1	0.02	0.10	0.0008	0.004	e	2.30 BSC		0.0905 BSC	
A2	1.55	1.65	0.0610	0.0649	e1	4.60 BSC		0.181 BSC	
b	0.66	0.84	0.026	0.033	E	6.70	7.30	0.264	0.287
b2	2.90	3.10	0.114	0.122	E1	3.30	3.70	0.130	0.146
C	0.23	0.33	0.009	0.013	L	0.90	-	0.035	-

Note: Controlling dimensions are in millimeters. Approximate dimensions are provided in inches

Soldering footprint

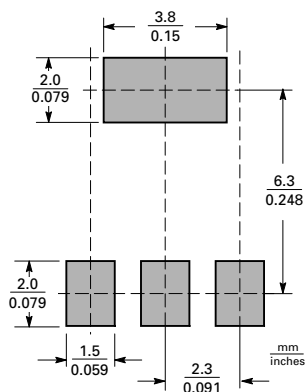

Package information - SOT223

Nominal weight

Nominal weight per device 112mg.

Tape and reel information

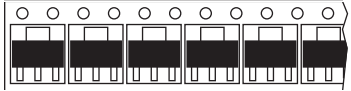
Orientation	Tape width (mm)	Reel size (inches)	No. of components	Tape option indicator
	12	7	1,000	TA
	12	13	4,000	TC

Embossed carrier tape configuration

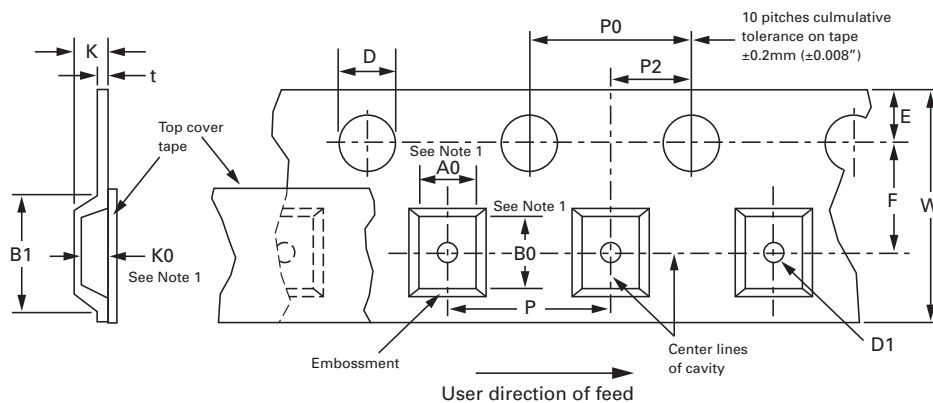

Dimensions mm (inches)	Tape size (mm)			
	8	12	16	24
A0, B0, K0	See note*	See note*	See note*	See note*
B1 (max.)	4.55 (0.179)	8.20 (0.323)	12.10 (0.476)	20.10 (0.791)
D	1.50 + 0.10 - 0.00	1.50 + 0.10 - 0.00	1.50 + 0.10 - 0.00	1.50 + 0.10 - 0.00
D1 (max.)	1.00 (0.039)	1.50 (0.059)	1.50 (0.059)	1.50 (0.059)
E	1.75 ± 0.10	1.75 ± 0.10	1.75 ± 0.10	1.75 ± 0.10
F	3.50 ± 0.10 (0.138 ± 0.004)	5.50 ± 0.05 (0.217 ± 0.002)	7.50 ± 0.10 (0.295 ± 0.004)	11.50 ± 0.10 (0.453 ± 0.004)
P	4.00 ± 0.10 (0.157 ± 0.004)	4.00 ± 0.10 (0.157 ± 0.004) 8.00 ± 0.10 (0.315 ± 0.004)	4.00 ± 0.10 (0.157 ± 0.004) 8.00 ± 0.10 (0.315 ± 0.004) 12.00 ± 0.10 (0.472 ± 0.004)	4.00 ± 0.10 (0.157 ± 0.004) to 20.00 ± 0.10 (0.787 ± 0.004) in 4.00 (0.157) increments
P0	4.00 ± 0.10	4.00 ± 0.10	4.00 ± 0.10	4.00 ± 0.10
P2	2.00 ± 0.05	2.00 ± 0.05	2.00 ± 0.05	2.00 ± 0.05
t (max.)	0.40	0.40	0.40	0.40
W	8.00 (0.315)	12.00 ± 0.30 (0.472 ± 0.012)	16.30 (0.642)	24.30 (0.957)

NOTES:

* A0, B0 and K0 dimensions are determined with respect to EIA/JEDEC rotational and lateral movement requirements (see fig. 1).

Package information - SOT223

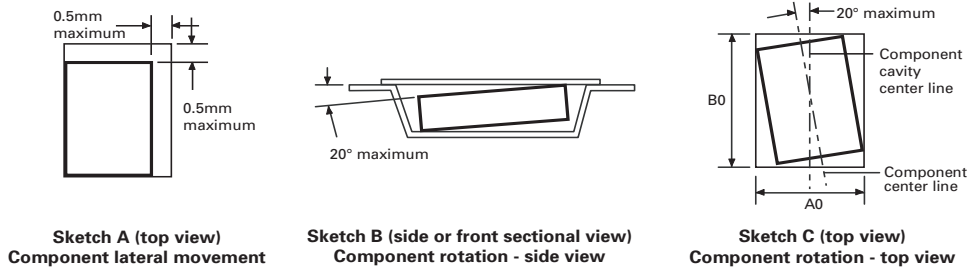
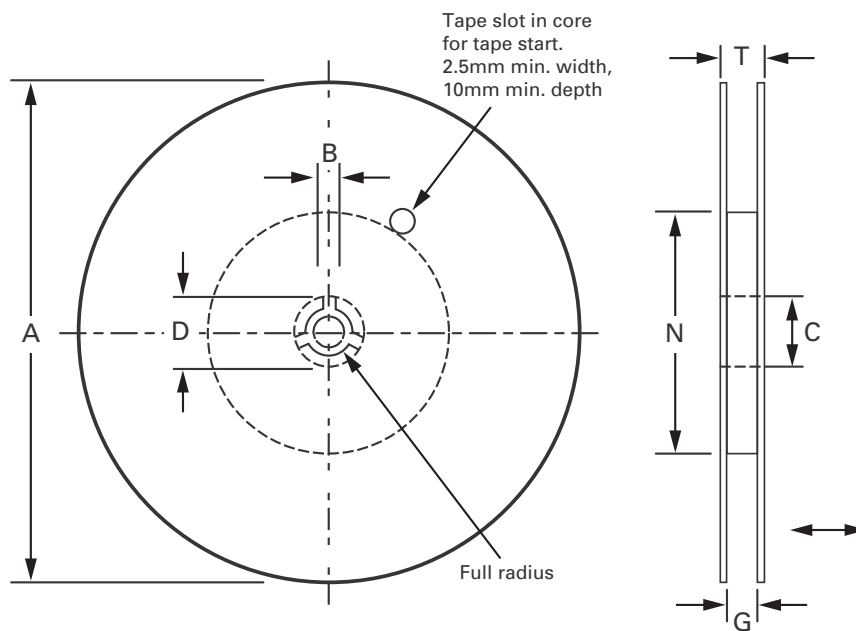

Figure 1 - rotational and lateral movement

Reel configuration



Tape option	A max.	B min.	C	D min.	N min.
TA	179 (7.047)	1.5 (0.06)	13.00 - 13.02 (0.512 - 0.52)	25.0 (0.984)	50 (1.969)
TC	330 (12.992)			20.2 (0.795)	

Tape size	G	T max.
8mm	8.4 -9.9 (0.33 - 0.39)	14.4 (0.567)
12mm	12.4 -16.4 (0.49 - 0.569)	18.4 (0.724)
16mm	16.4 -18.4 (0.65 - 0.729)	22.4 (0.882)
24mm	24.4 - 26.4 (0.96 - 1.039)	30.4 (1.197)

This publication is issued to provide outline information only which (unless agreed by the company in writing) may not be used, applied or reproduced for any purpose or form part of any order or contact or be regarded as a representation relating to the products or services concerned. The company reserves the right to alter without notice the specification, design, price or conditions of supply of any product or service.