



SPECIFICATION
IP-35155A (P)
PSIV350604C

USER PART-NAME
PUBLISHING DATE
REFORMING DATE

BN44-00124E
2006.06.30

(A) POWER

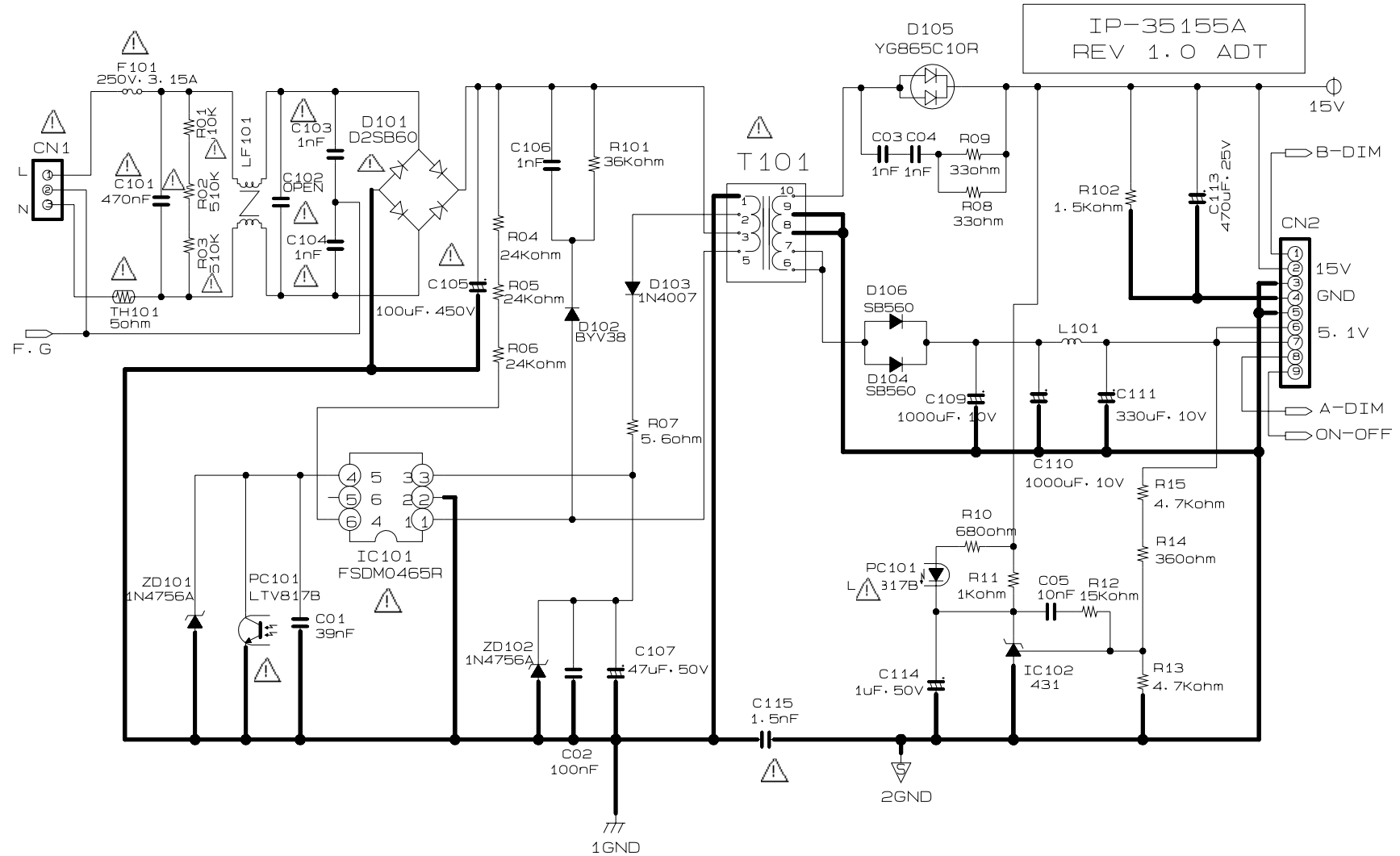



SPECIFICATION
IP-35155A (P)
PSIV350604C

USER PART-NAME
PUBLISHING DATE
REFORMING DATE

BN44-00124E
2006.06.30

(B) INVERTER

