

Battery interface

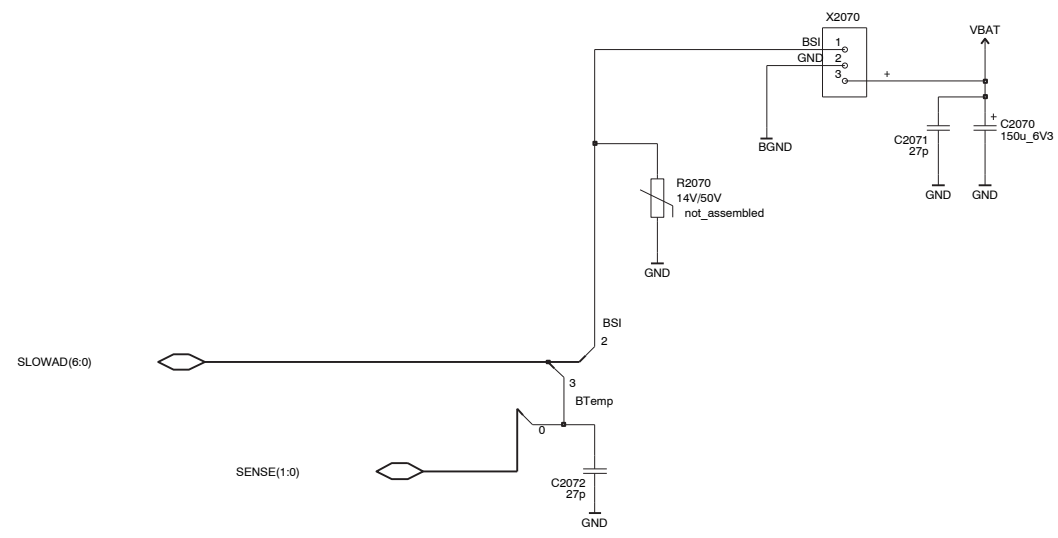

Headset

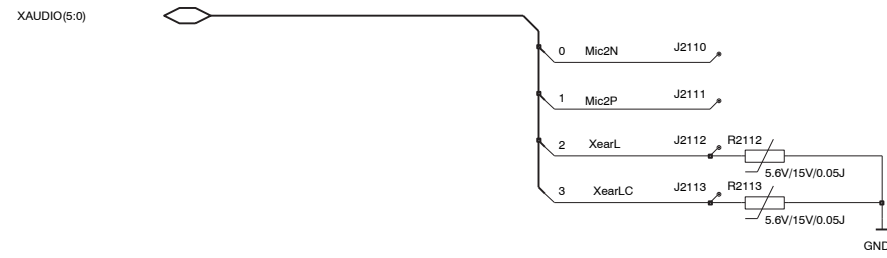

Earpiece

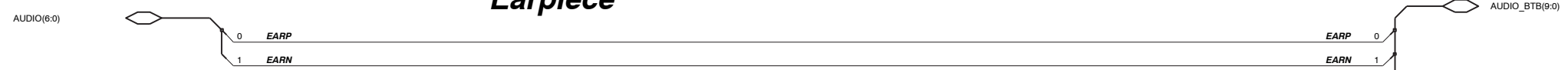

Microphone

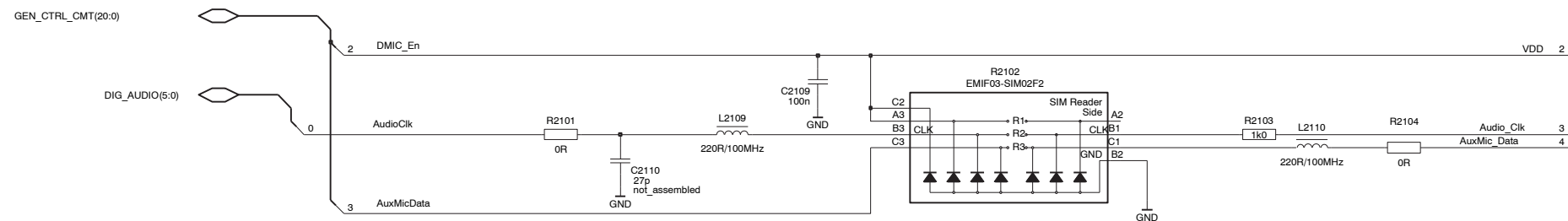

Vibra

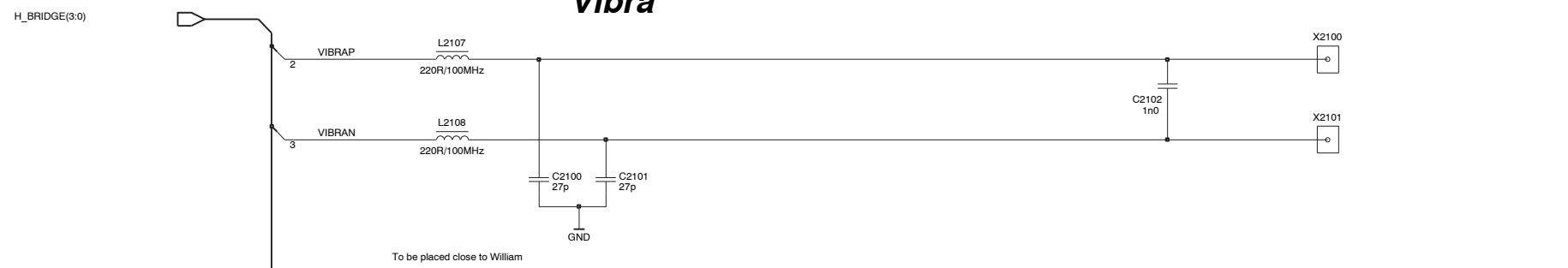

IHF

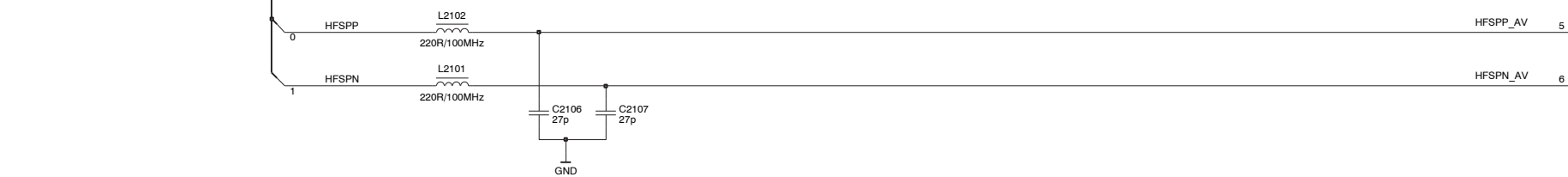

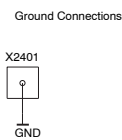
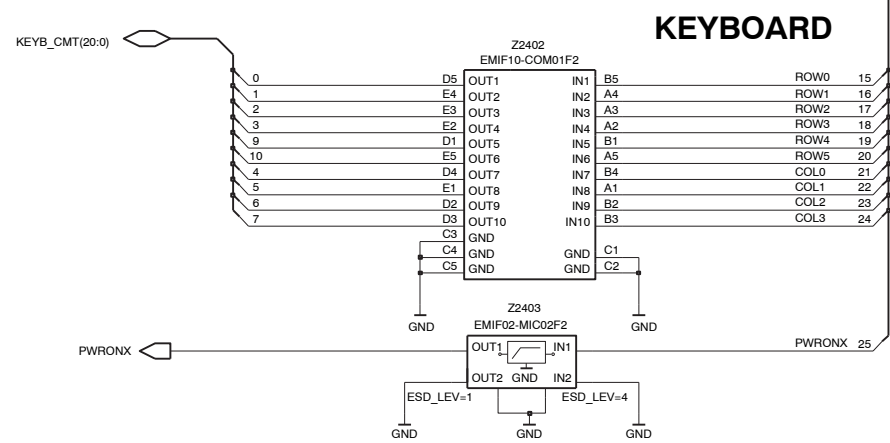
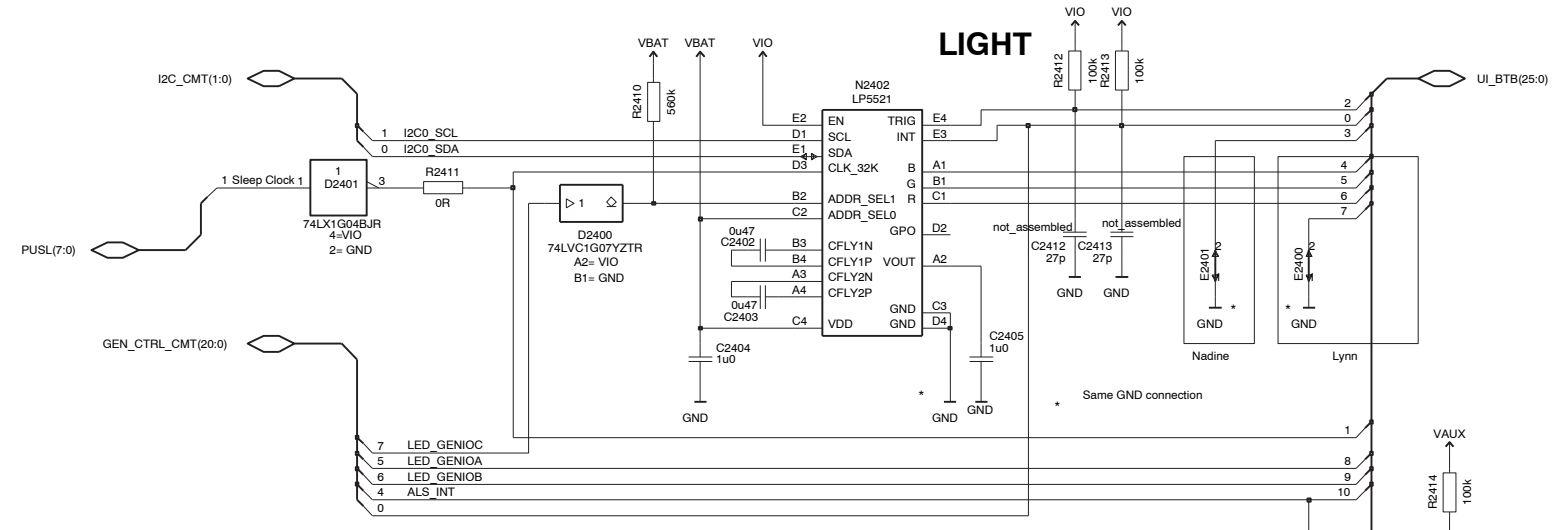
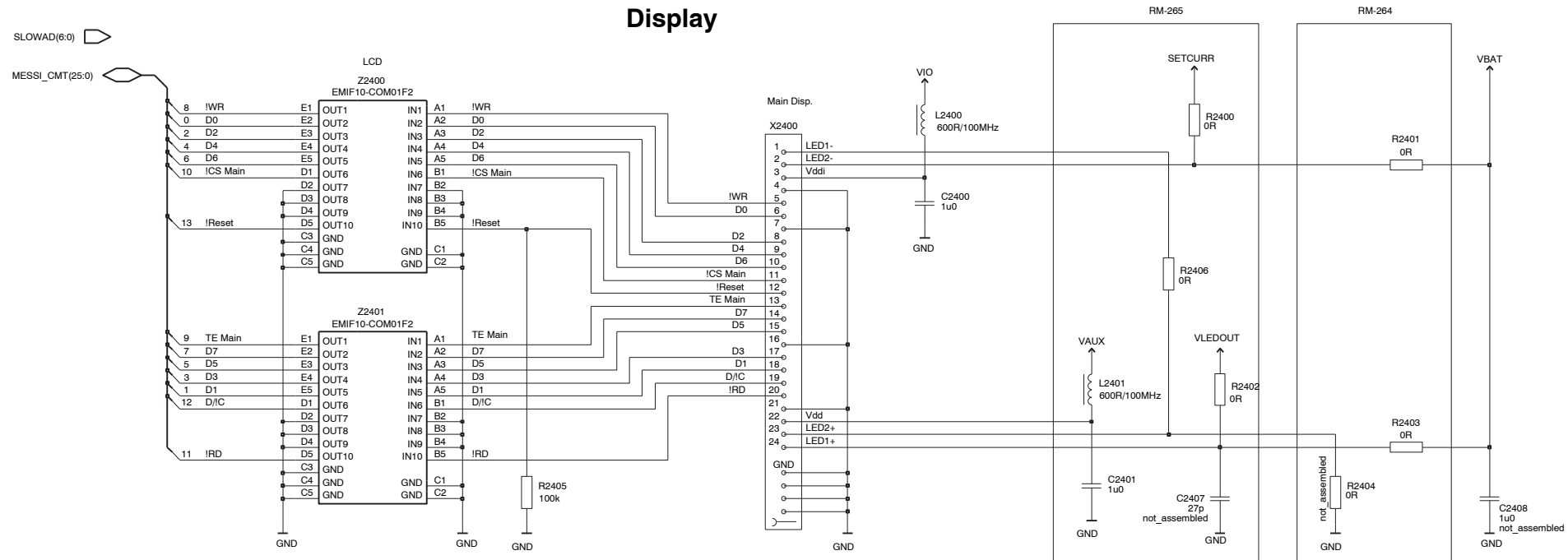

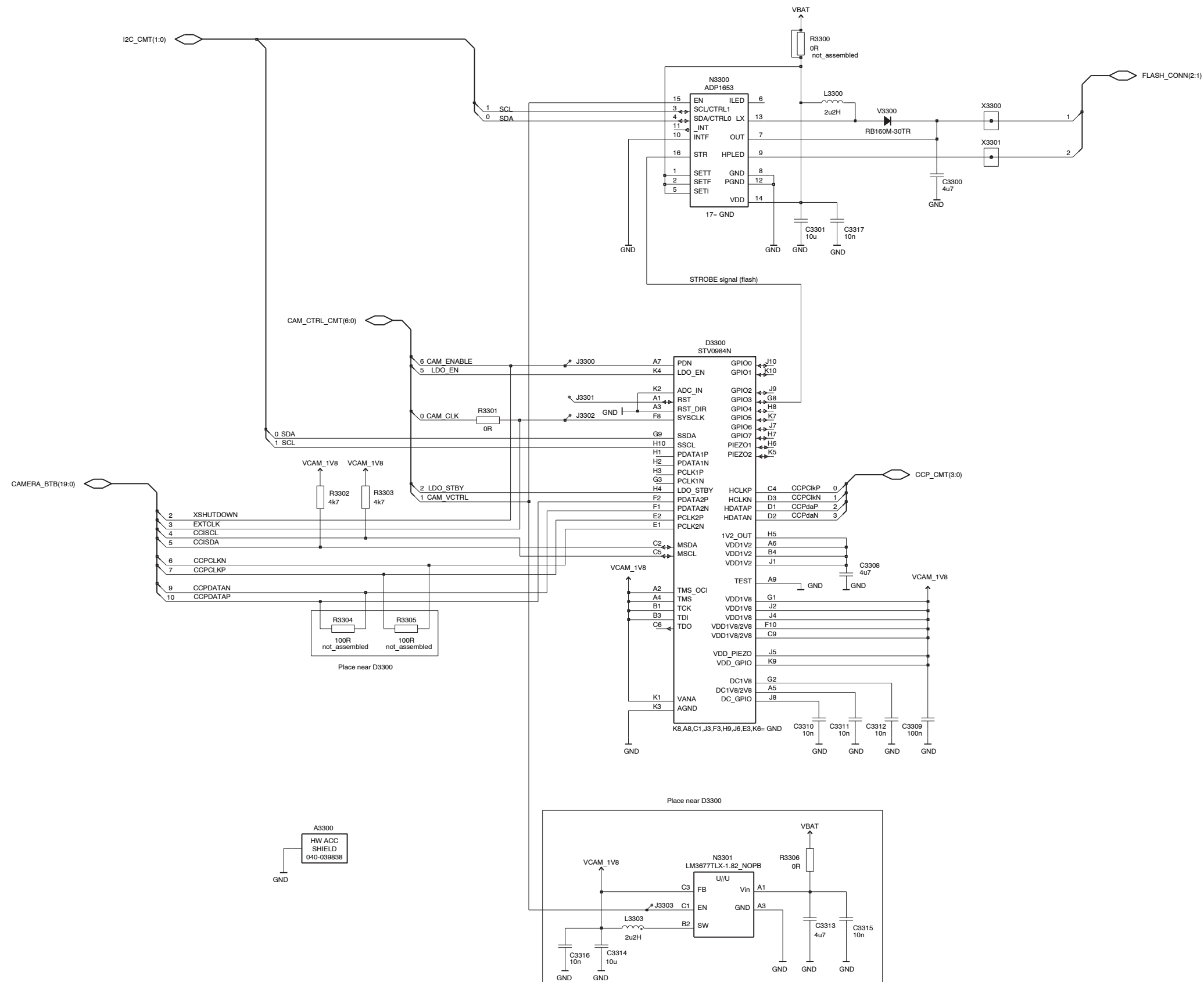

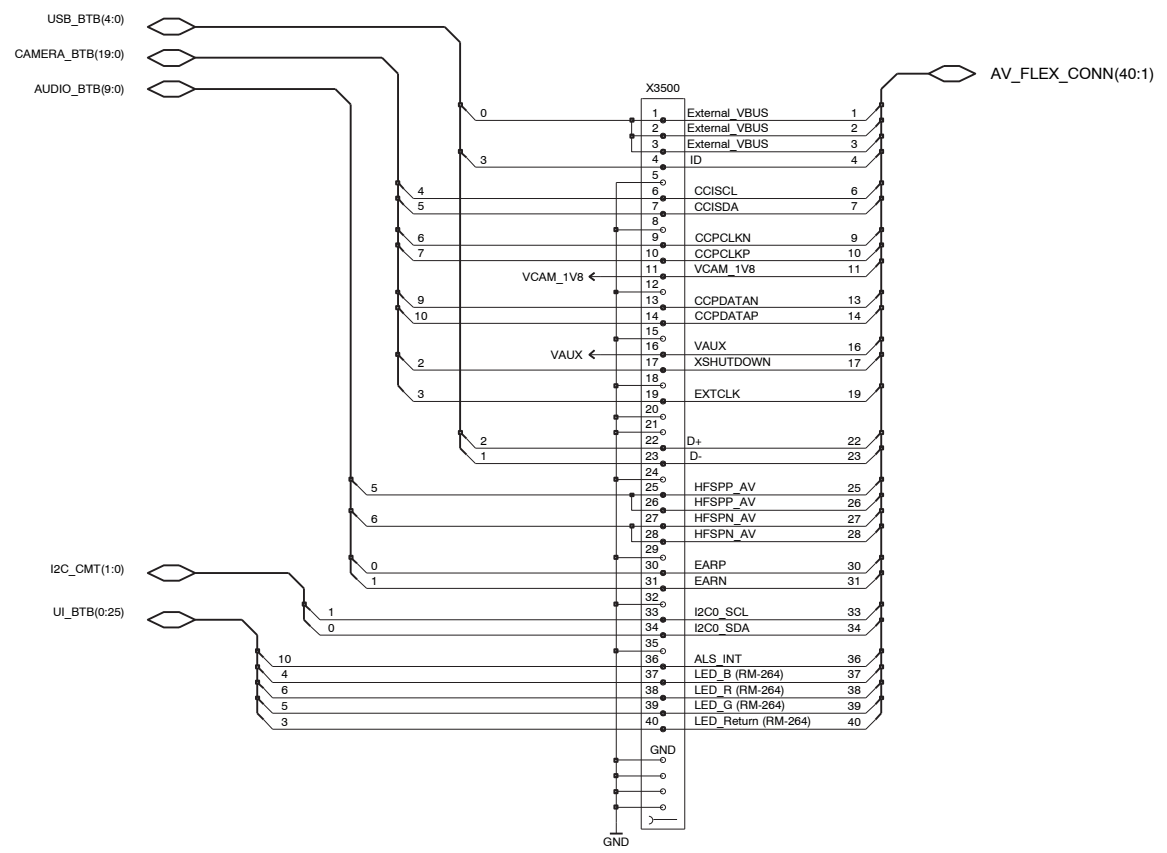

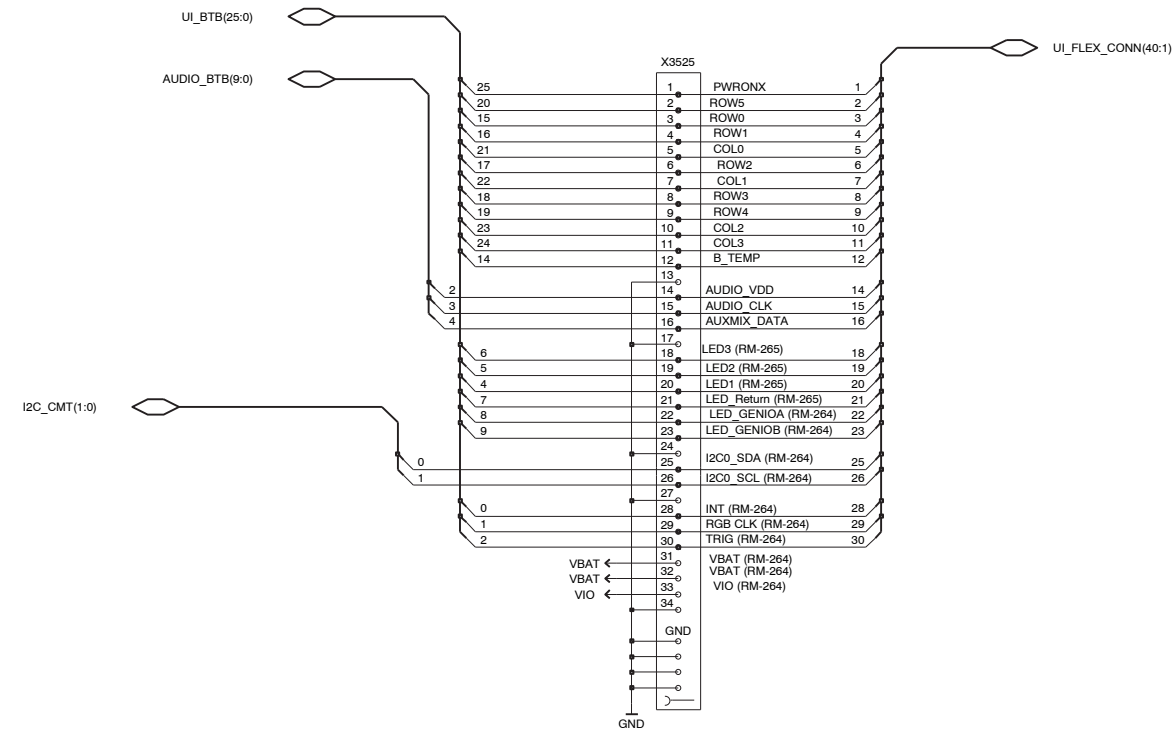

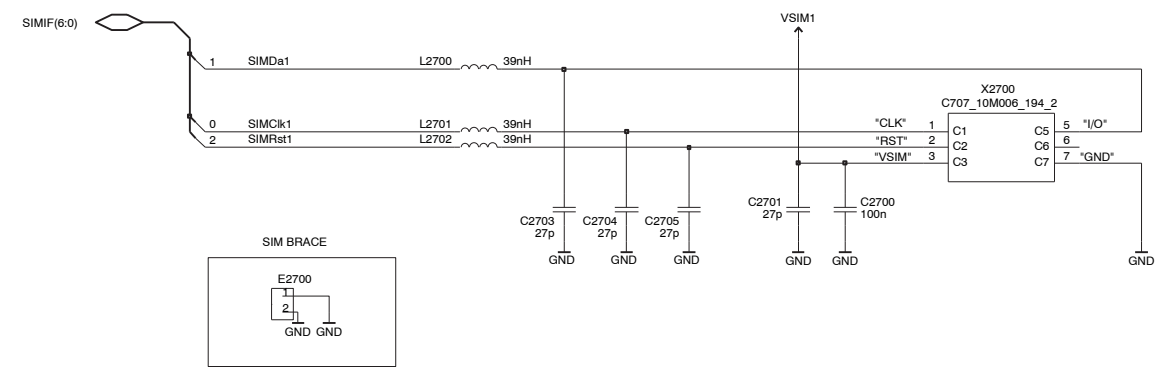

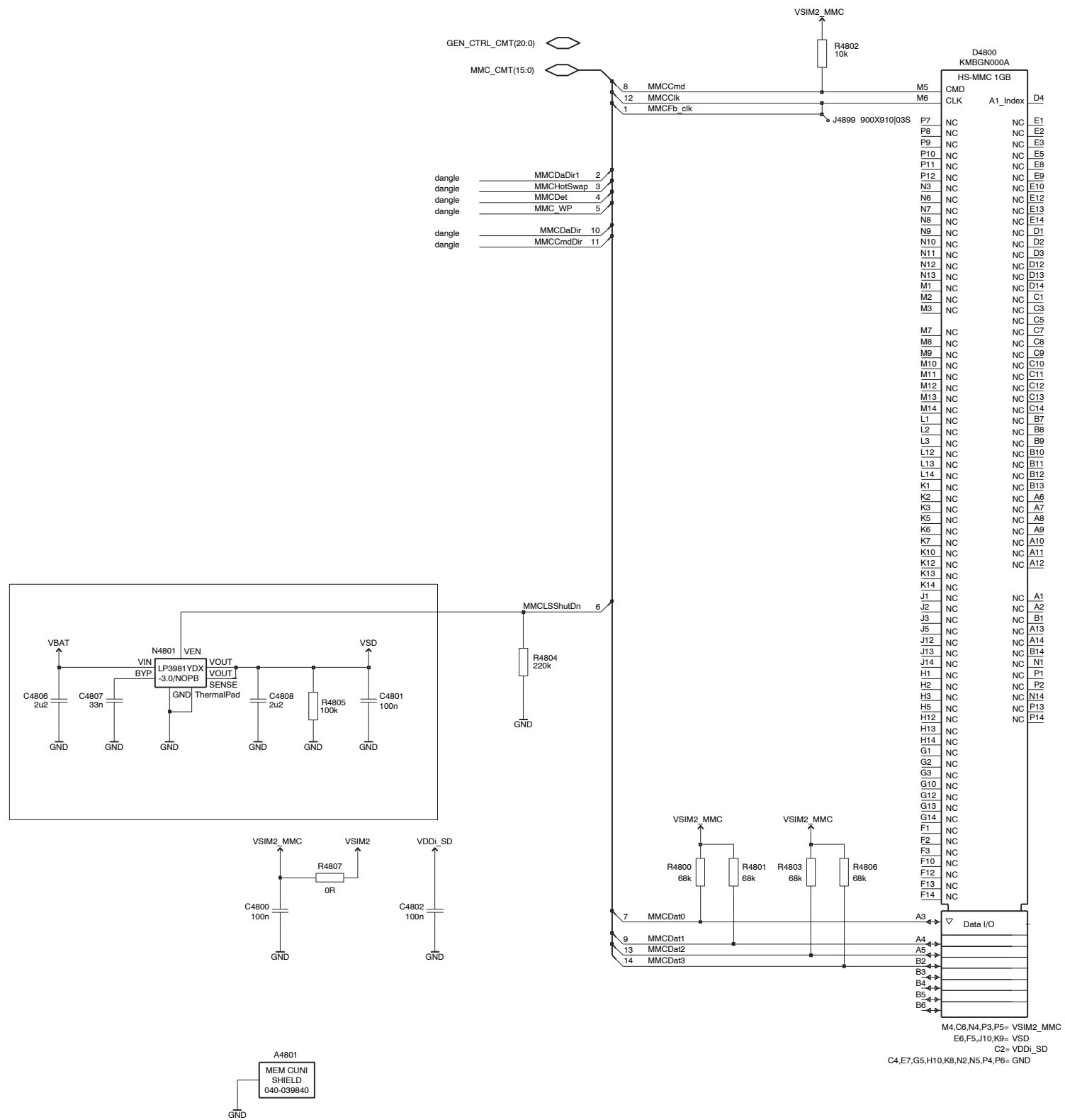

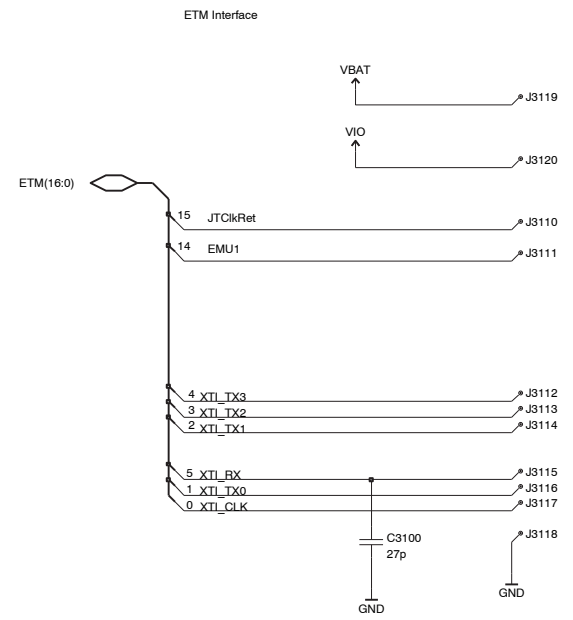
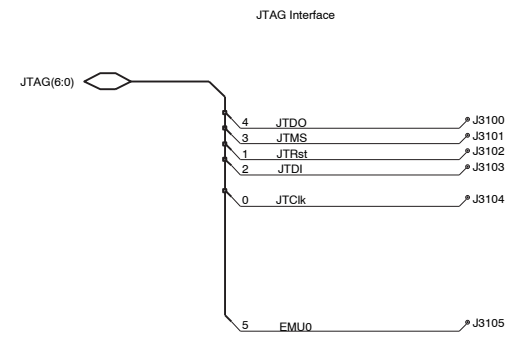

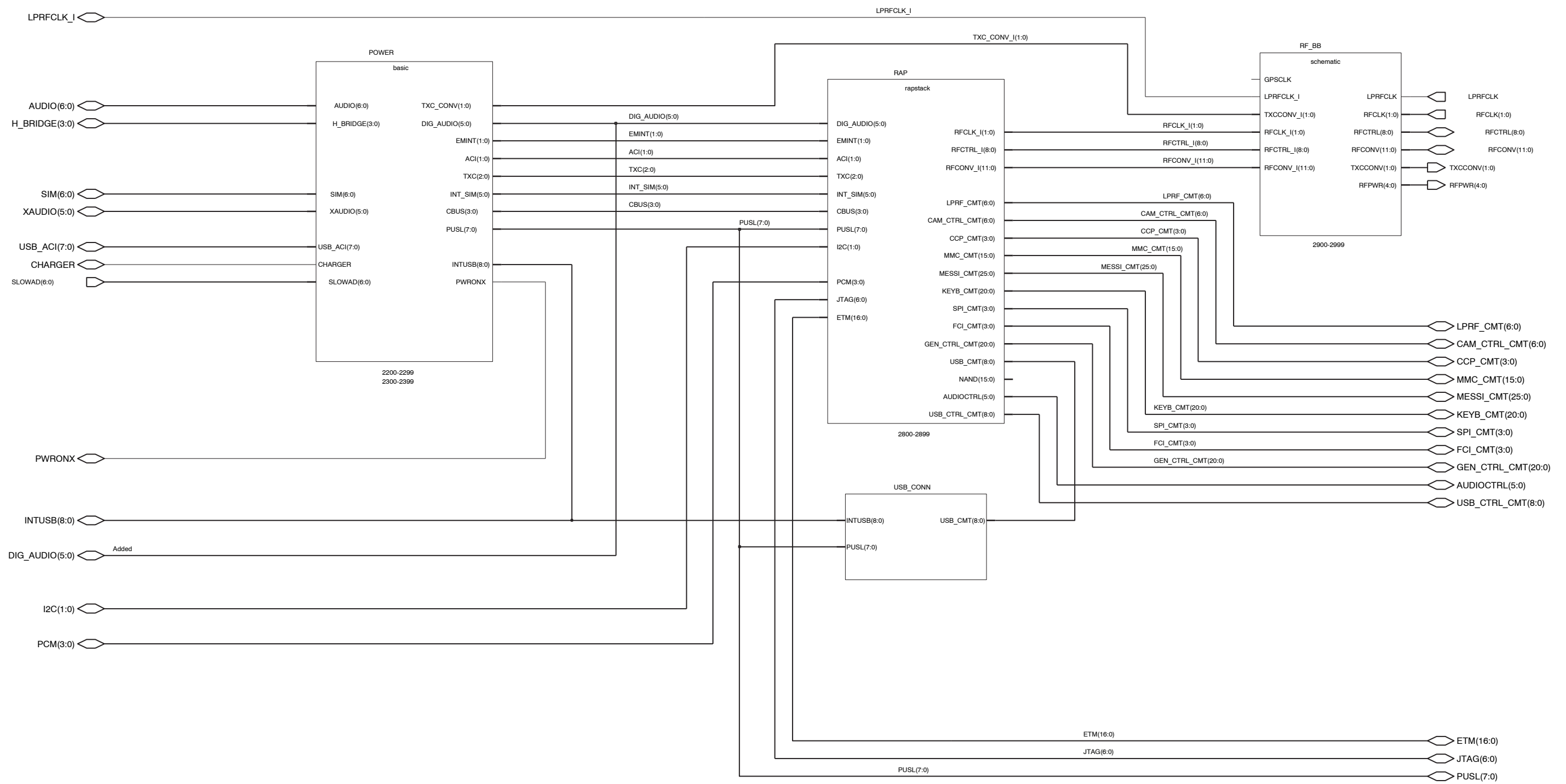

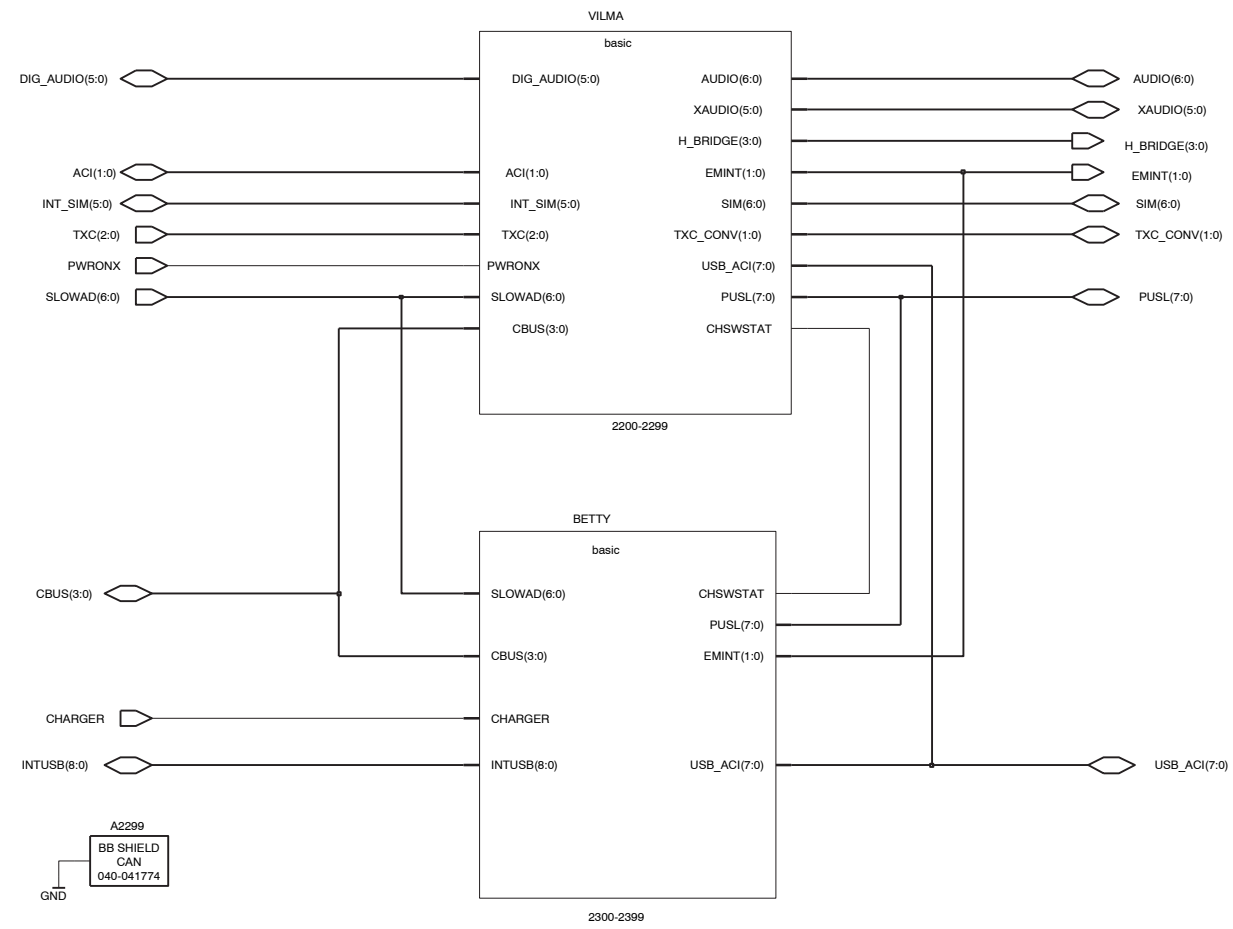

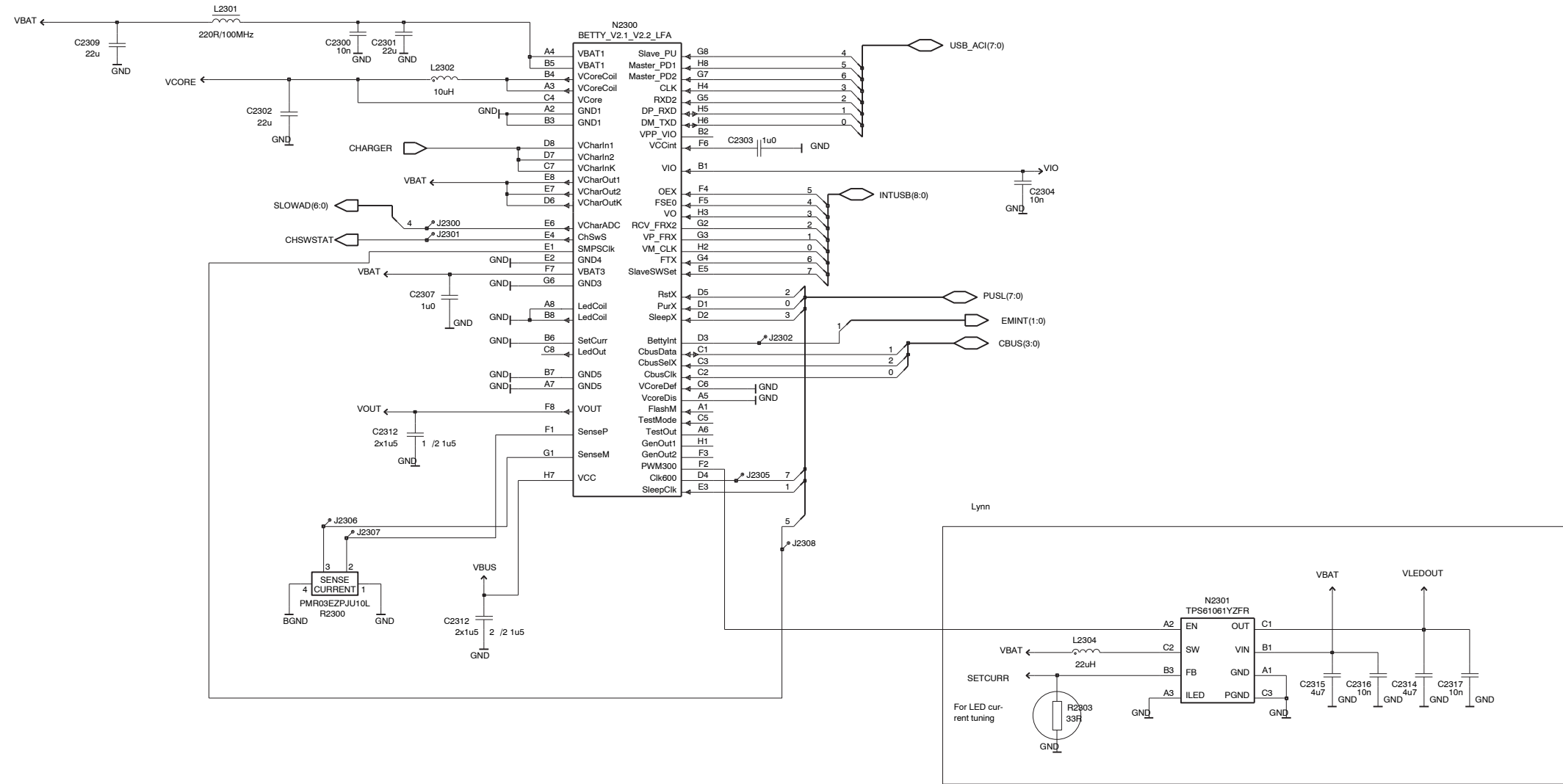

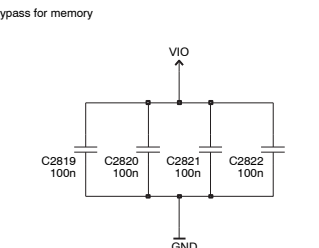
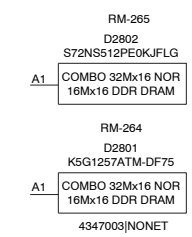
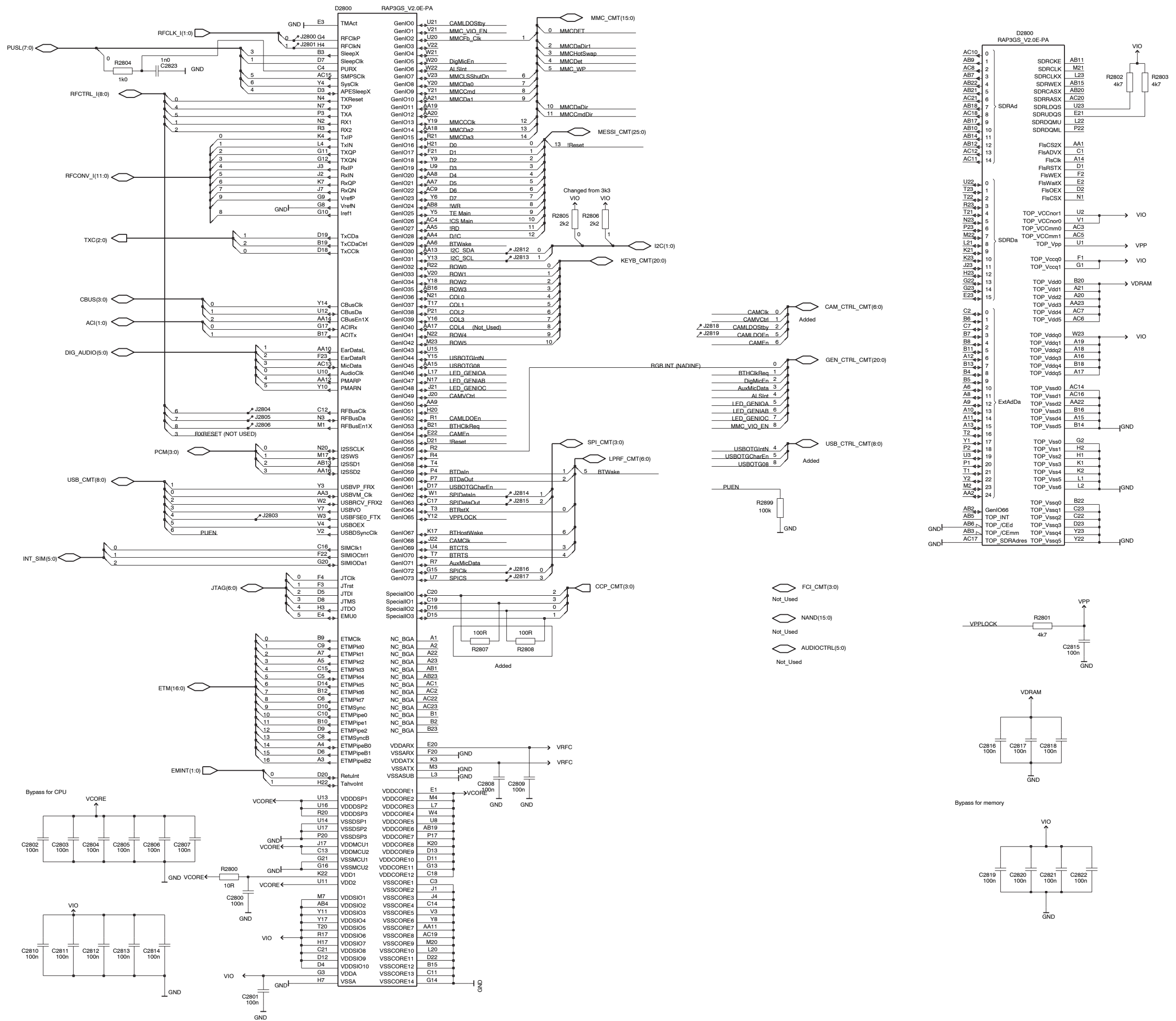

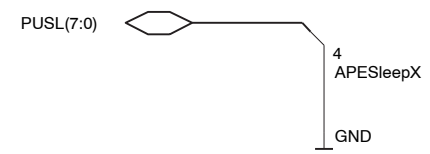
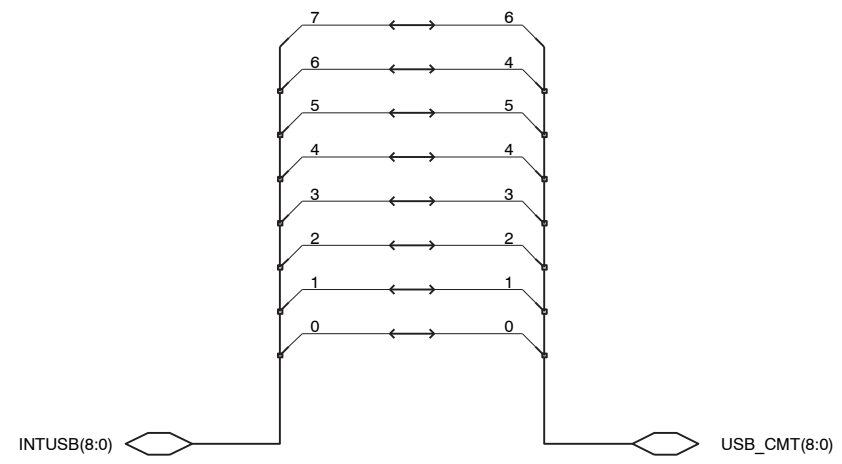

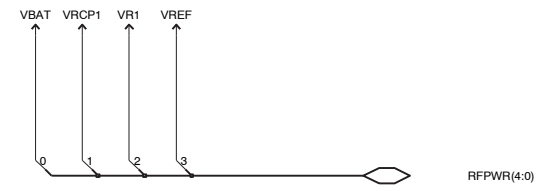
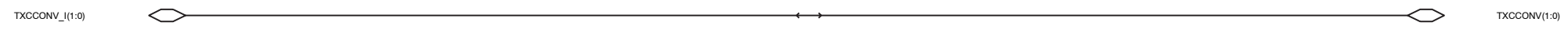
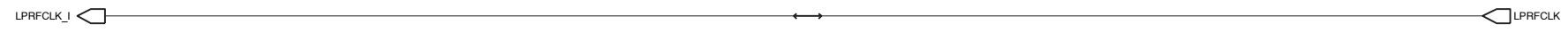

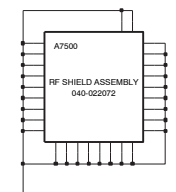
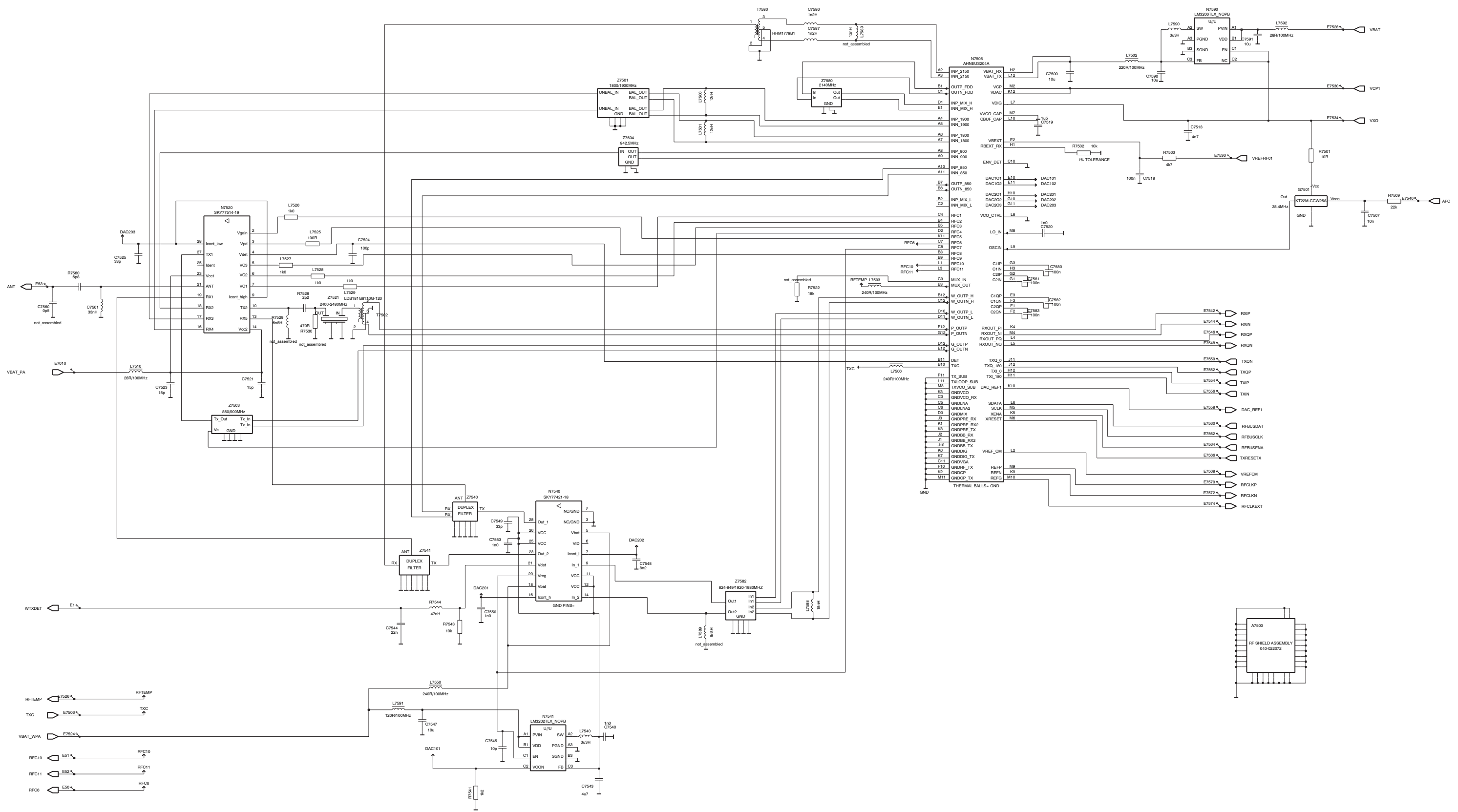

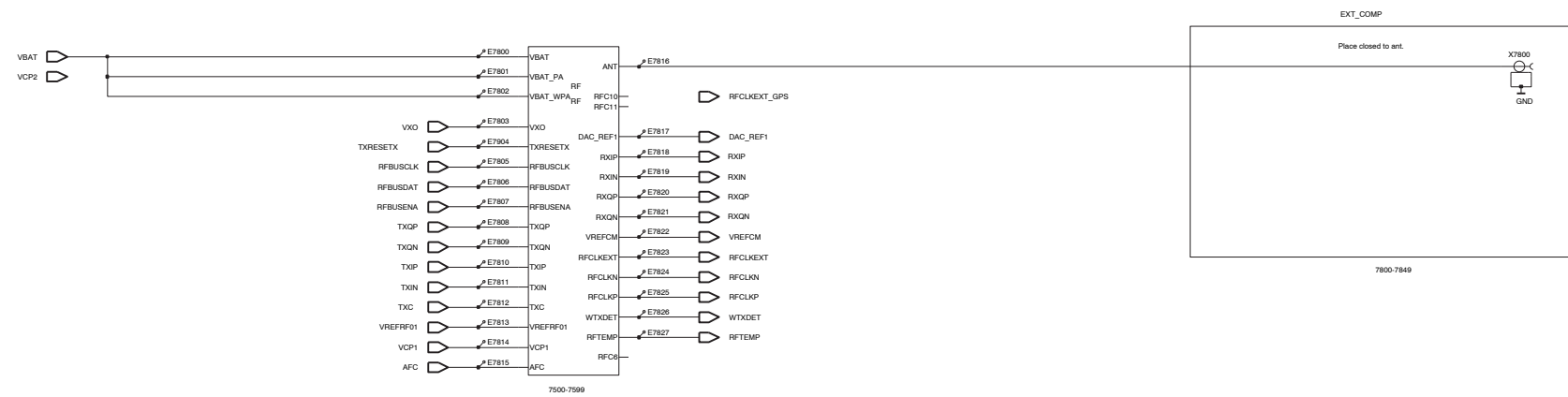

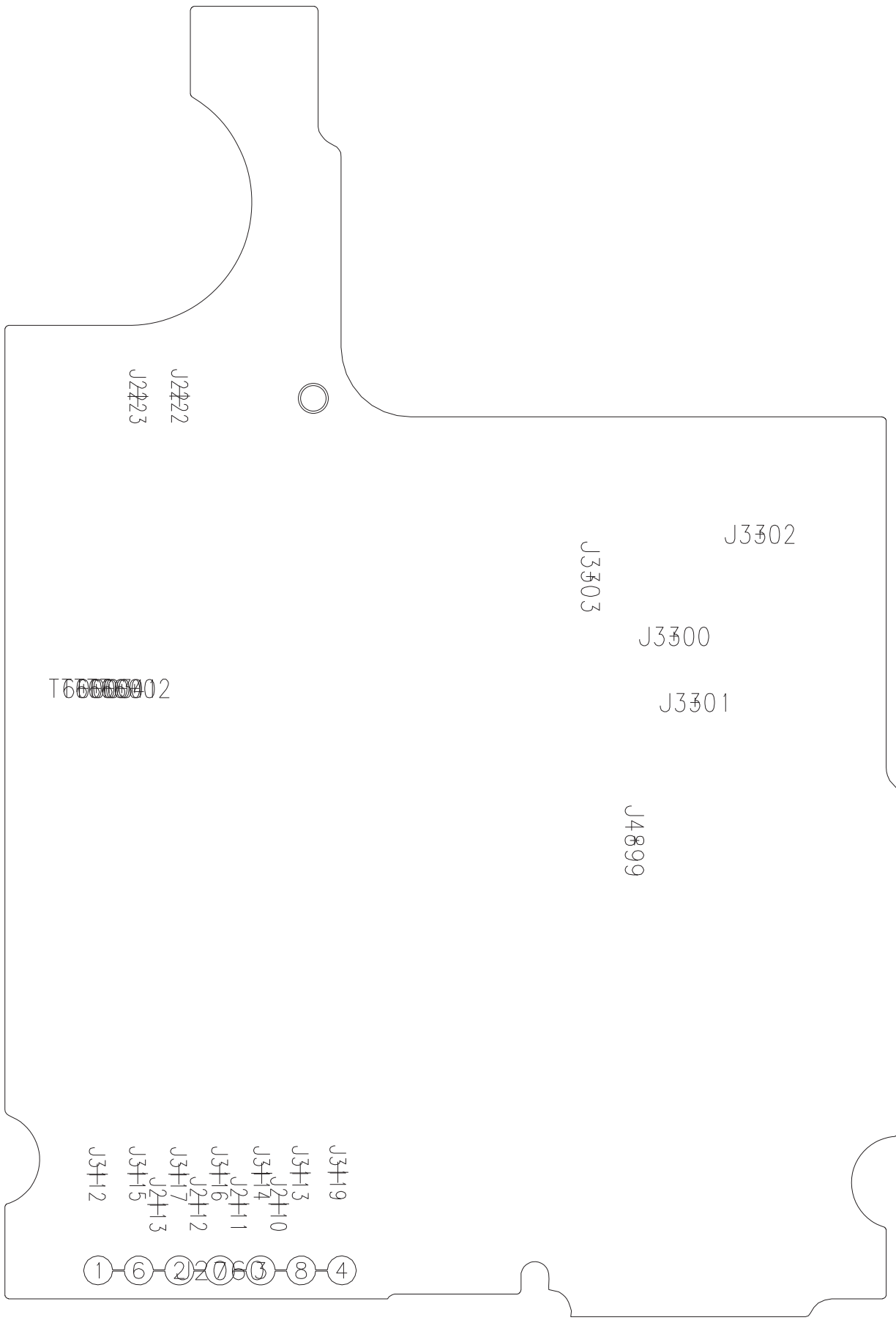

2dva_06a_Tp_Drw_B.385.pdf

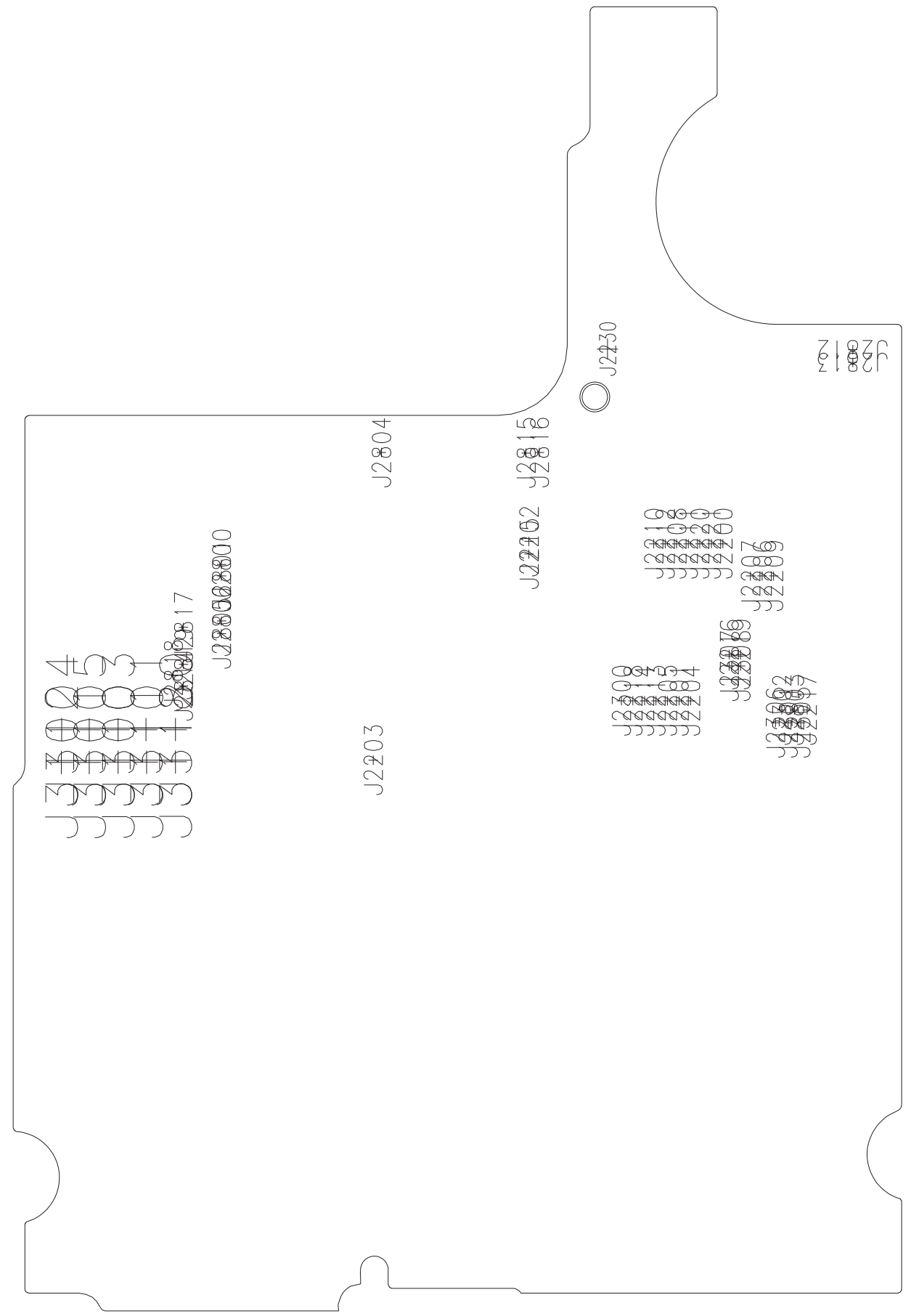

2dva_06a_Tp_Drw_T.385.pdf

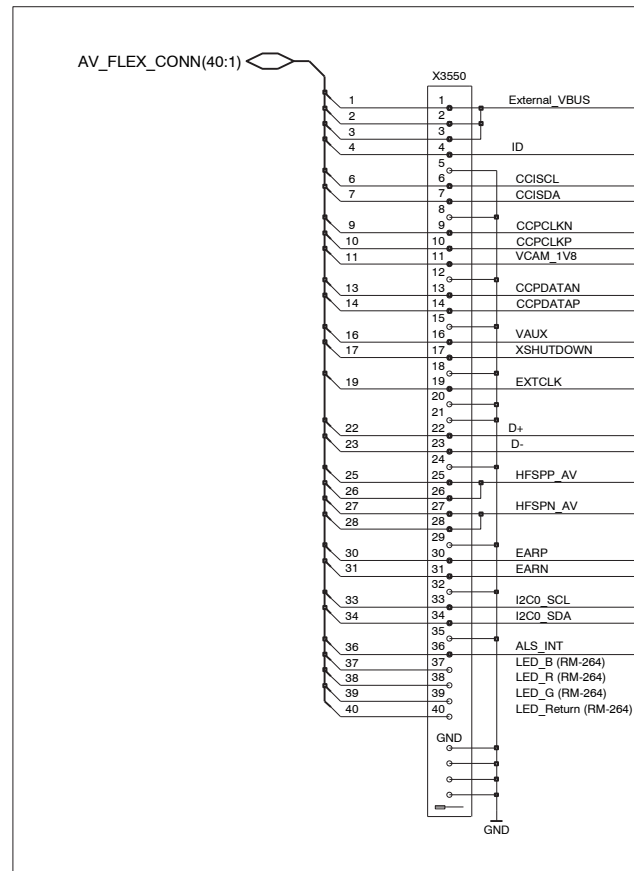

3550-3574
Board_to_board

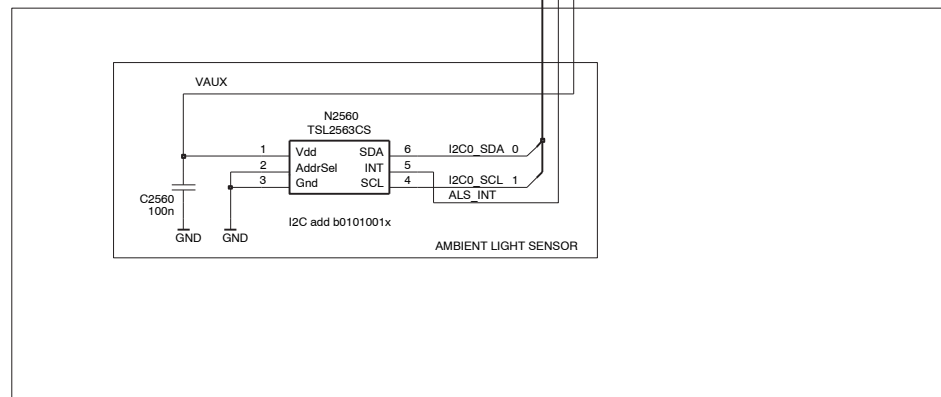

UI
2560-2599

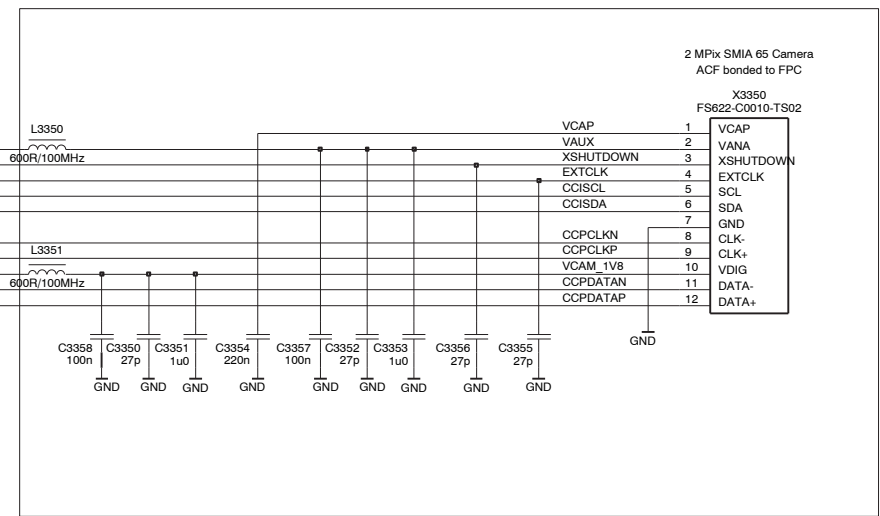
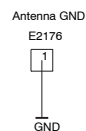

CAMERA
3350-3379

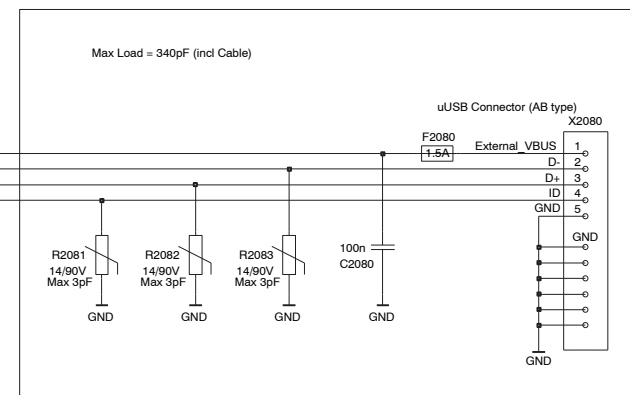

SYS_CONN
2080-2099

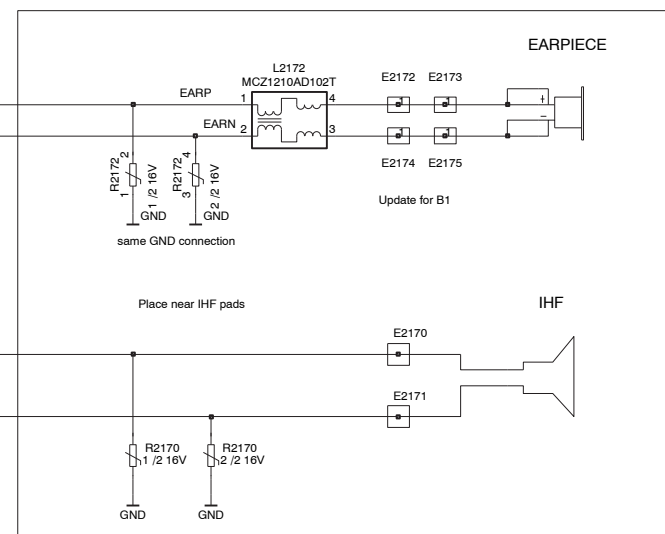

AUDIO
2170-2184

2dvd_04a_asmdrw_t.pdf

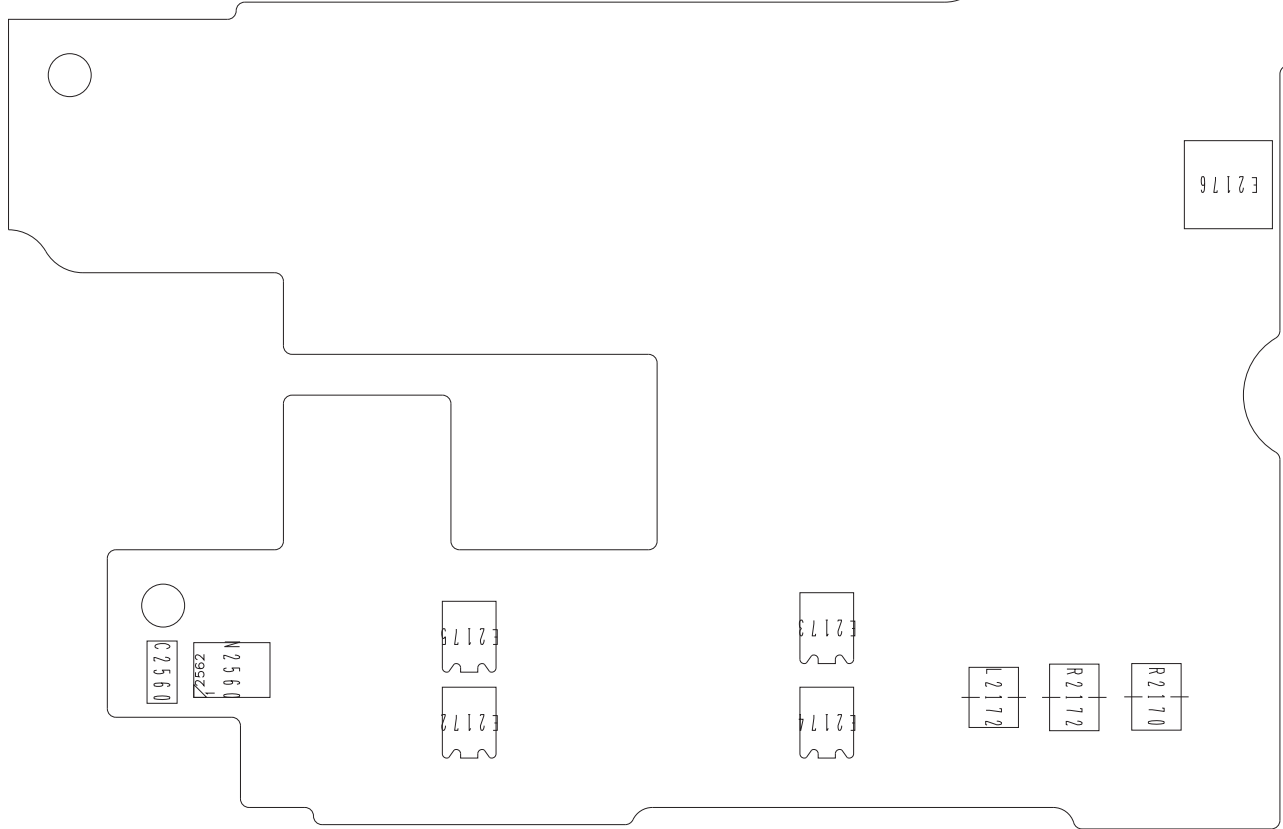

X3550

2dvd_04a_asmdrw_b.pdf

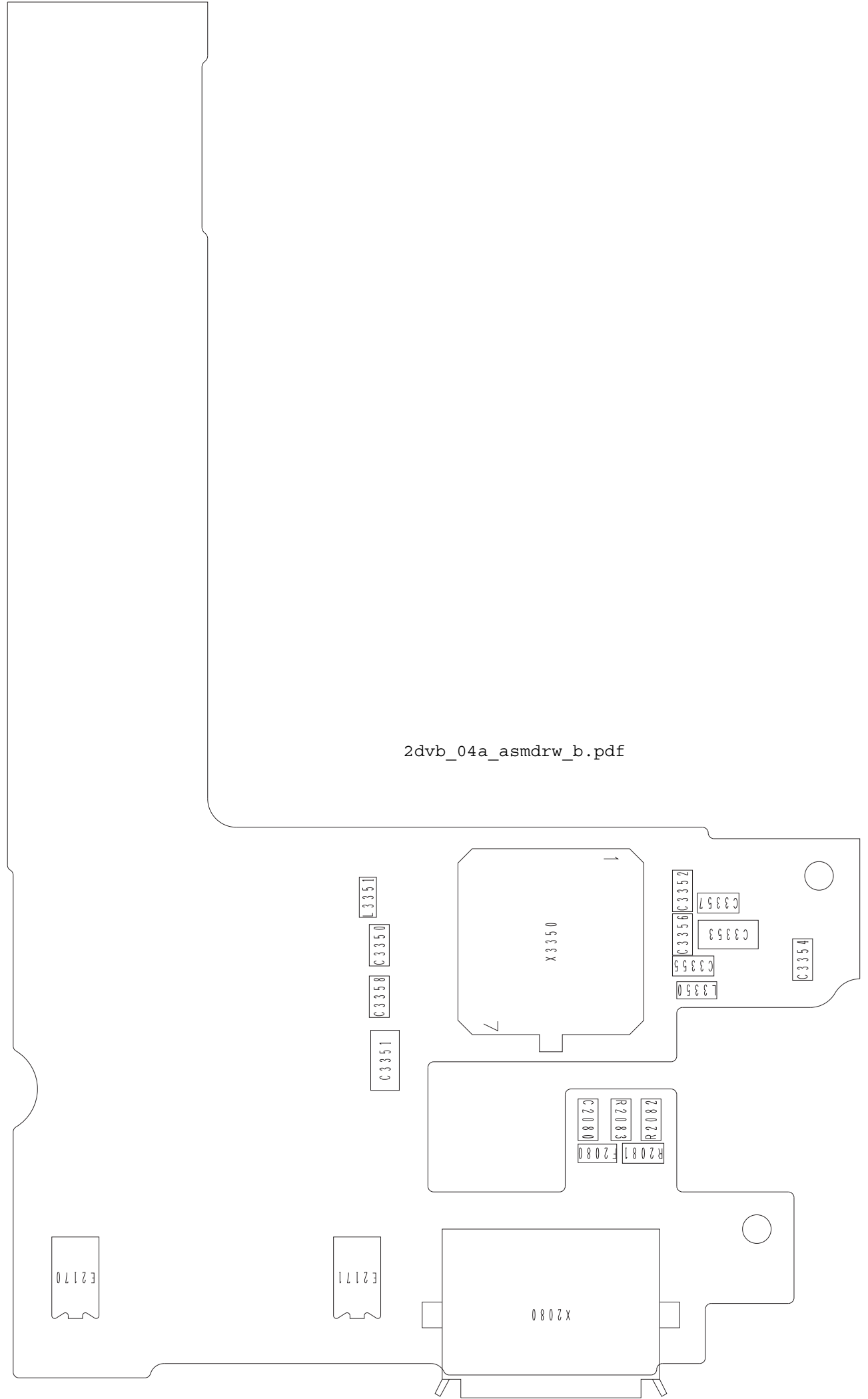

Keyboard

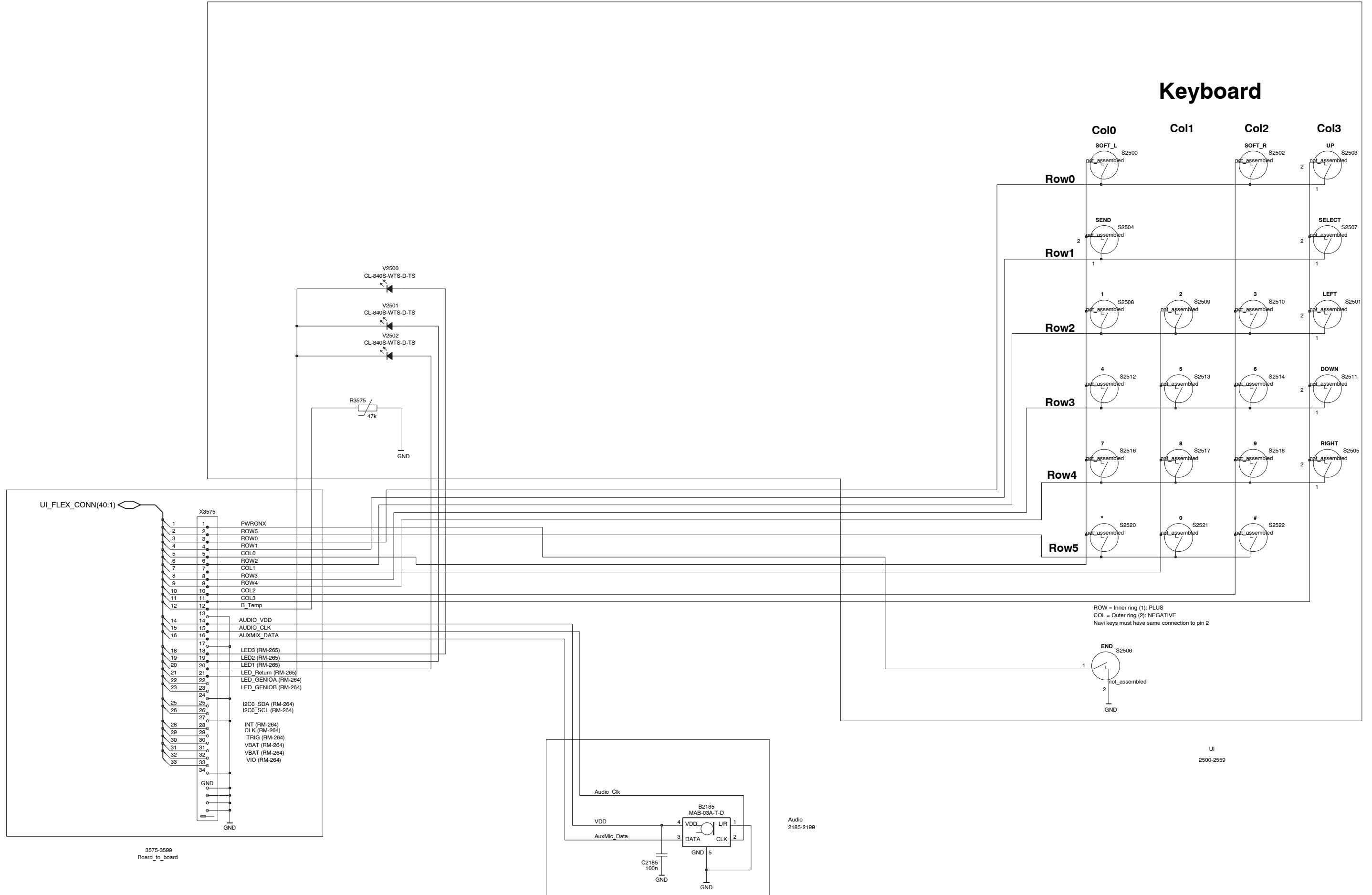

2dvd_02a_asmdrw_t.pdf

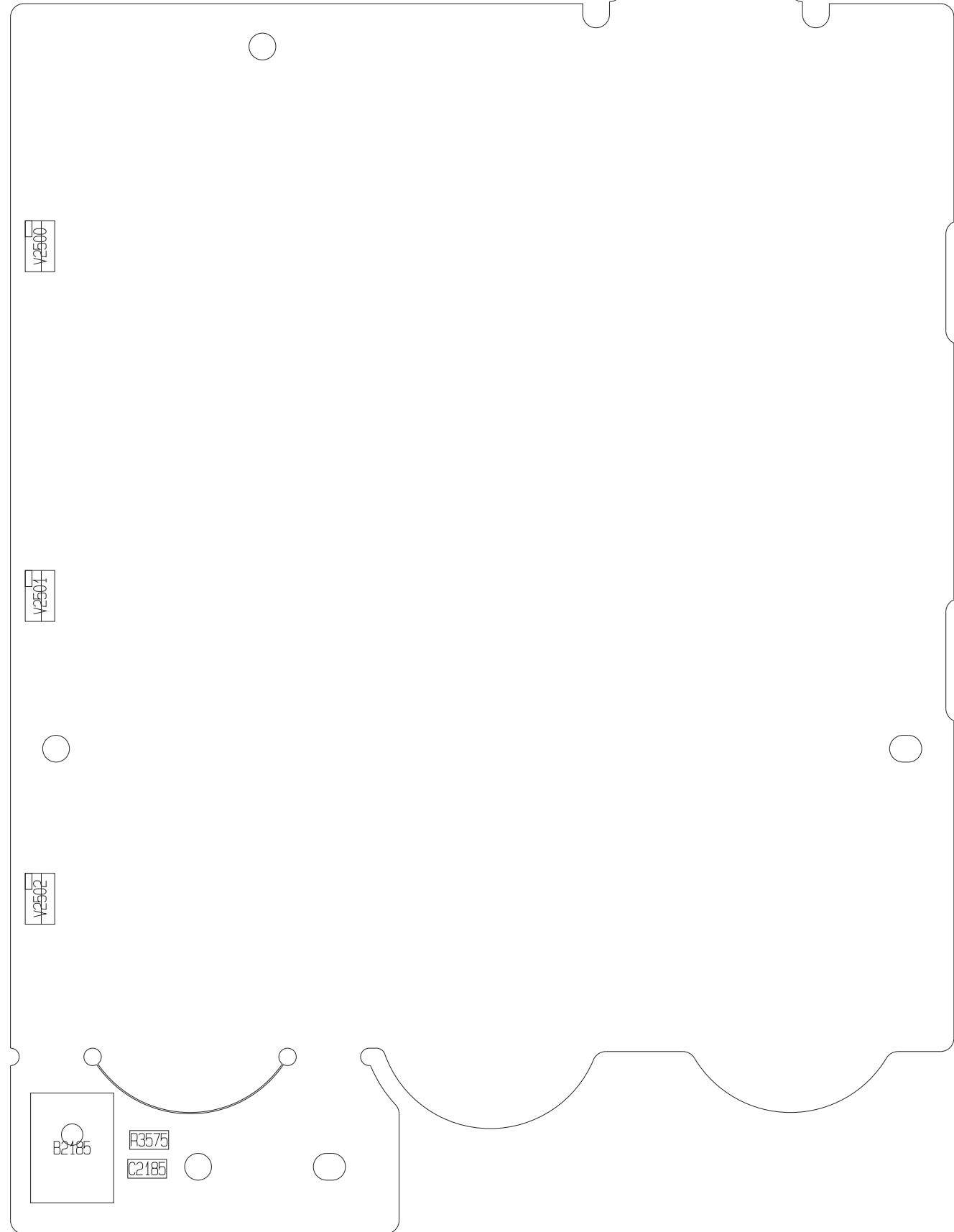

X3575

2dvd_02a_asmdrw_b.pdf

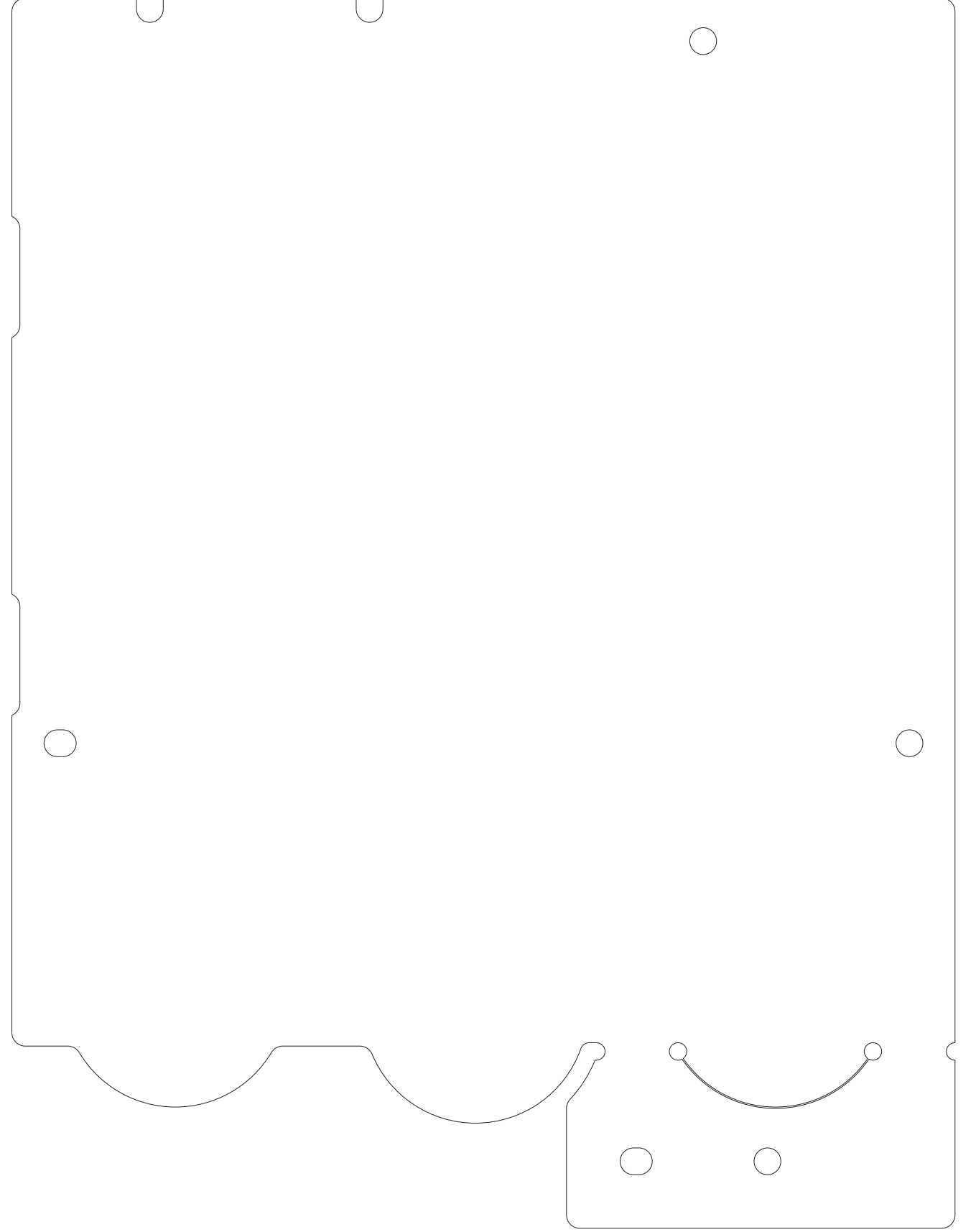

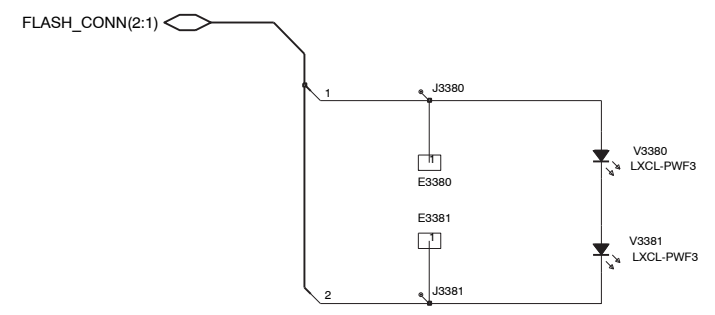

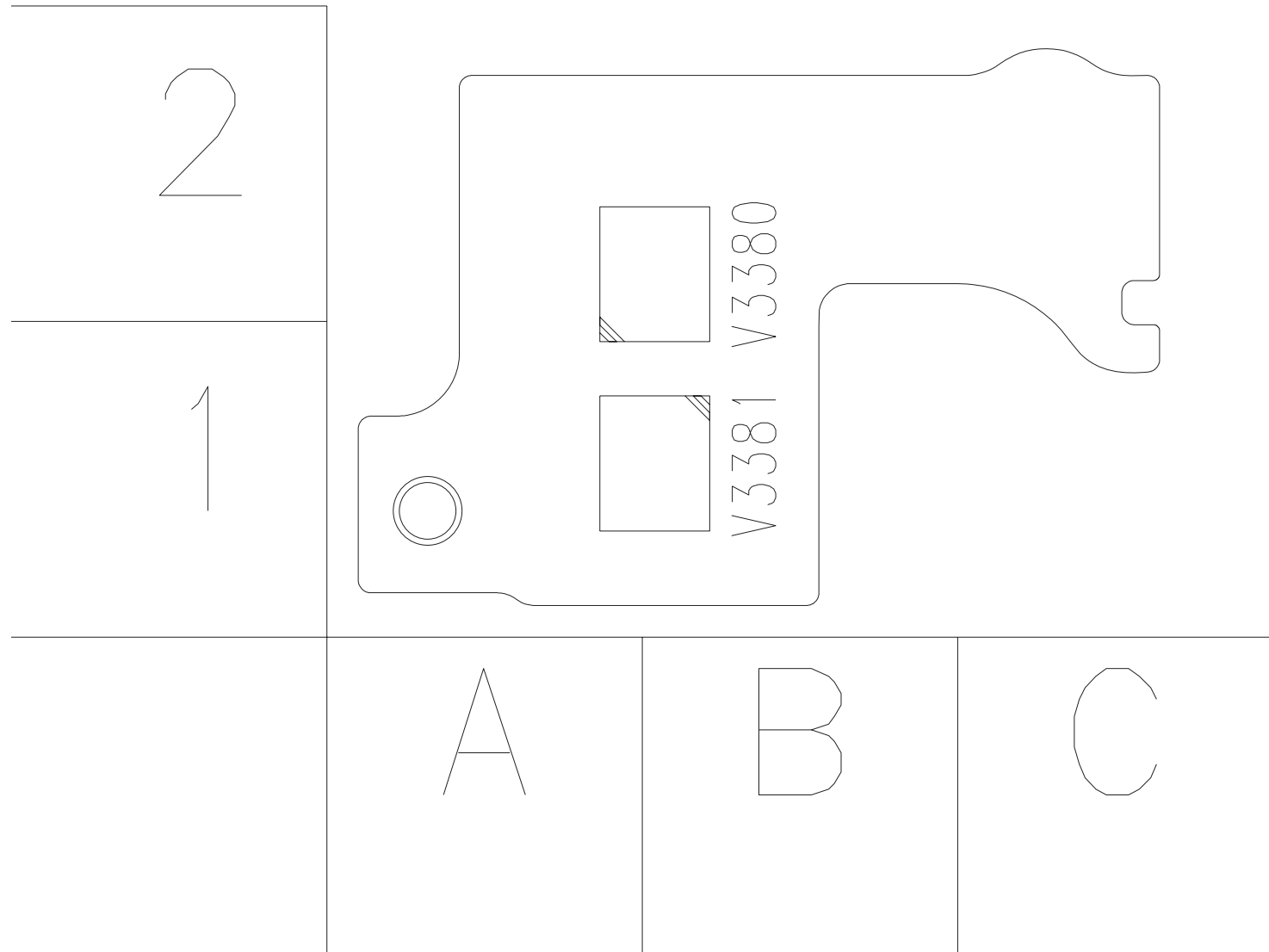

2dvf_02a_AsmDrw_T.15.pdf

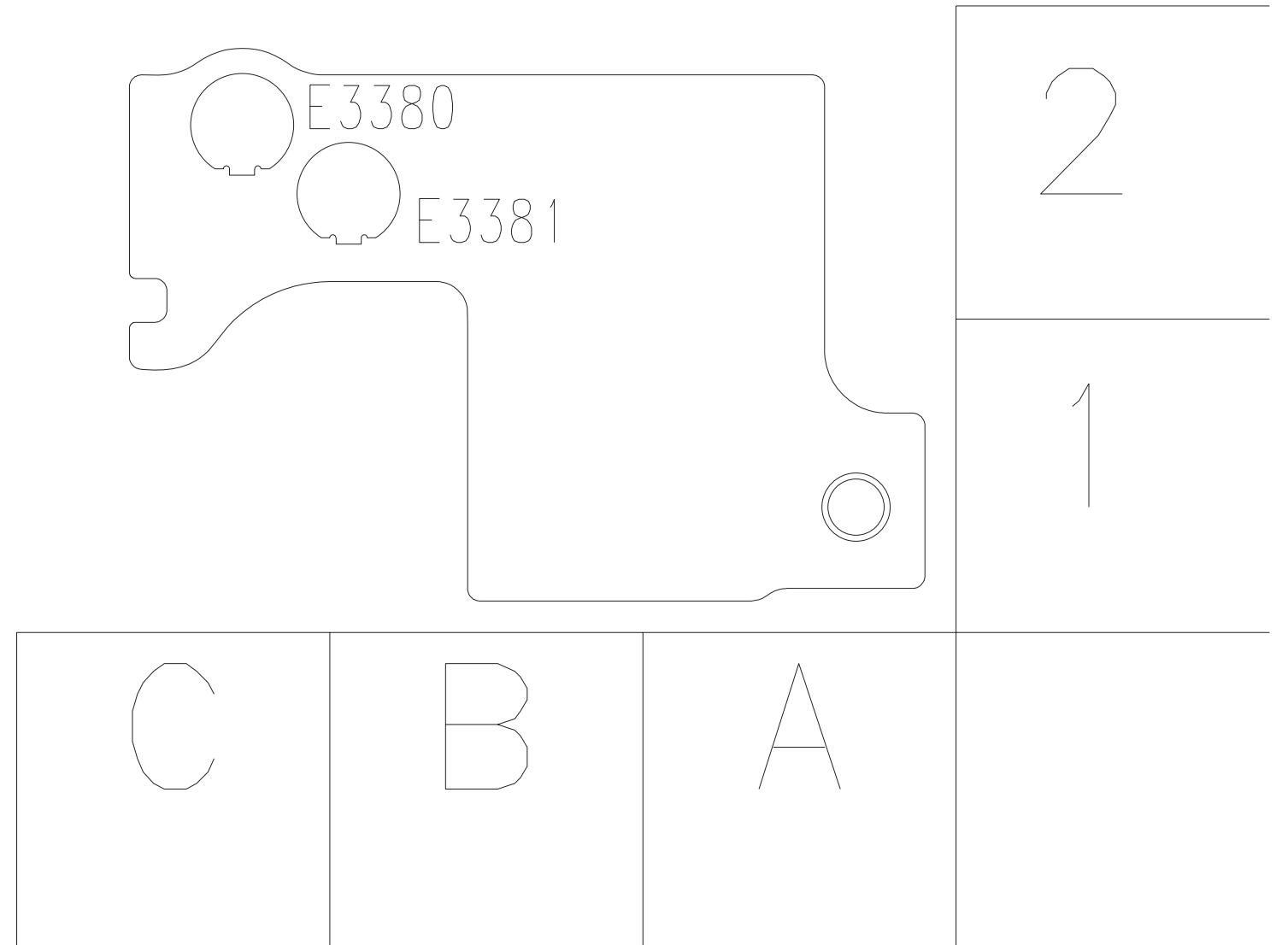

2dvf_02a_AsmDrw_B.15.pdf

J3380

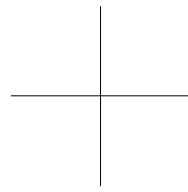
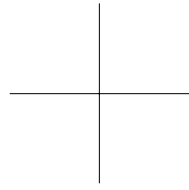

J3380

